

# Bourns® Inductors

## *Product Selection Guide*



*NOTE: The data sheet specifications contained herein were updated in September, 2010. For NEW Inductor products released since this Selection Guide was published in 2005, please visit our website at [www.bourns.com](http://www.bourns.com).*

# Bourns® Inductors

---

## **I. Surface Mount Chip Inductors**

Product Capability Matrix .....	4
Product Specifications:	
• <i>CM Series Wirewound Sealed Chip Inductors</i> .....	8
• <i>CW Series Wirewound Open Chip Inductors</i> .....	17
• <i>CE Series Multi-Layer Ceramic Chip Inductor</i> .....	20
• <i>CV Series Multi-Layer Ferrite Chip Inductor</i> .....	22
• <i>CS Series Multi-Layer Ferrite Shielded Chip Inductors</i> .....	24
• <i>CI Series Multi-Layer Ceramic Chip Inductors</i> .....	28
• <i>CF Series Multi-Layer Ferrite High Current Chip Inductors</i> .....	32

## **II. Surface Mount Power Inductors**

Product Capability Matrix .....	38
Product Specifications:	
• <i>SDR Series Non-Shielded Power Inductors</i> .....	45
• <i>SRR Series Shielded Power Inductors</i> .....	84
• <i>SRU Series Shielded Power Inductors</i> .....	126

## **III. Surface Mount Chip Beads**

Product Capability Matrix .....	152
Product Specifications:	
• <i>MH Series High Current Chip Beads</i> .....	154
• <i>MG, MU, MZ Series High Impedance Chip Beads</i> .....	163
• <i>MT Series Low Current/Low Impedance Chip Beads</i> .....	172
• <i>MA Series Chip Ferrite Bead Arrays</i> .....	177

## **IV. Through-Hole Inductors**

Product Capability Matrix .....	182
Product Specifications:	
• <i>RLB Series Radial Inductors</i> .....	183
• <i>FSR1013 Radial Shielded Inductors</i> .....	190
• <i>PT121 Radial High Q Inductors</i> .....	191
• <i>LPA Series Axial Power Inductors</i> .....	192
• <i>LPV Series Radial Power Inductors</i> .....	193

## **V. Surface Mount Data Line Dual Chokes**

Product Capability Matrix .....	196
Product Specifications:	
• <i>DR221 Series Dual Chokes</i> .....	197
• <i>DR331 Series Dual Chokes</i> .....	199

---

## **I. Surface Mount Chip Inductors**

Product Capability Matrix .....	4
• <i>Product Selection Guide</i> .....	4
• <i>Size Comparison Guide</i> .....	4
• <i>Inductance Range</i> .....	5
• <i>Frequency Range</i> .....	5
• <i>Current Range</i> .....	6
• <i>Lab Kit Offering</i> .....	6
• <i>Soldering Profile</i> .....	7

### Product Specifications

• <i>Model CM45 Series 4.5mm Ferrite Wirewound Chip Inductors</i> .....	8
• <i>Model CM32 Series 3.2mm Ferrite Wirewound Chip Inductors</i> .....	8
• <i>Model CM25 Series 2.5mm Ferrite Wirewound Chip Inductors</i> .....	8
• <i>Model CM20 Series 2.0mm Ferrite Wirewound Chip Inductors</i> .....	8
• <i>Model CM16 Series 1.6mm Alumina Laser-Cut Chip Inductors</i> .....	8
• <i>Model CM10 Series 1.0mm Alumina Laser-Cut Chip Inductors</i> .....	8
• <i>Model CW25 Series 2.5mm Alumina Wirewound Chip Inductors</i> .....	17
• <i>Model CW20 Series 2.0mm Alumina Wirewound Chip Inductors</i> .....	18
• <i>Model CW16 Series 1.6mm Alumina Wirewound Chip Inductors</i> .....	19
• <i>Model CE20 Series 1.25mm Ceramic Multi-Layer Chip Inductor</i> .....	20
• <i>Model CV20 Series 1.25mm Ferrite Multi-Layer Chip Inductor</i> .....	22
• <i>Model CS32 Series 3.2mm Ferrite Multi-Layer Chip Inductors</i> .....	24
• <i>Model CS20 Series 2.0mm Ferrite Multi-Layer Chip Inductors</i> .....	26
• <i>Model CI20 Series 2.0mm Ceramic Multi-Layer Chip Inductors</i> .....	28
• <i>Model CI16 Series 1.6mm Ceramic Multi-Layer Chip Inductors</i> .....	30
• <i>Model CF25 Series 2.5mm Ferrite Multi-Layer Chip Inductors</i> .....	32
• <i>Model CF32 Series 3.2mm Ferrite Multi-Layer Chip Inductors</i> .....	33
• <i>Model CF45 Series 4.5mm Ferrite Multi-Layer Chip Inductors</i> .....	34

# Surface Mount Chip Inductor Capability Matrix



## Product Selection Guide

Model	Technology		Construction		Shielded	Preferred Models	Lab Kit Availability	Size - mm (L x W x H)
	Wirewound	Multi-Layer	Open	Sealed				
CE201210		•		•			•	2.0 x 1.25 x 1.25
CF252016		•		•	•	•	•	2.5 x 2.0 x 1.6
CF322513		•		•	•	•	•	3.2 x 2.5 x 1.3
CF453215		•		•	•	•	•	4.5 x 3.2 x 1.5
CI160808		•		•		•	•	1.6 x 0.8 x 0.8
CI201210		•		•		•	•	2.0 x 1.25 x 1.0
CS201212		•		•	•	•	•	2.0 X 1.25 X 1.25
CS321613		•		•	•	•	•	3.2 X 1.6 X 1.3
CW160808	•		•				•	1.6 X 0.8 X 0.8
CW201212	•		•				•	2.1 X 1.5 X 1.3
CW252016	•		•				•	2.75 X 2.6 X 2.0
CM100505	•			•		•		1.0 x 0.5 x 0.5
CM160808	•			•		•	•	1.6 x 0.8 x 0.8
CM201212	•			•		•	•	2.0 X 1.25 X 1.25
CM252016	•			•		•	•	2.5 X 2.0 X 1.6
CM322522	•			•		•	•	3.2 X 2.5 X 2.2
CM453232	•			•		•	•	4.5 X 3.2 X 3.2
CV201210		•		•	•		•	2.0 x 1.25 x 1.25

## Size Comparison Guide

Description	(Inches)	0402	0603	0805	1008	1206	1210	1812
	(Millimeters)	1005	1608	2012	2520	3216	3225	4532
Wirewound Sealed				CM201210	CM252016		CM322513	CM453232
Wirewound Open			CW160808	CW201210	CW252016			
Laser-cut Wire		CM100505	CM160808					
Multi-Layer Ceramic			CI160808	CE/CI201210				
Multi-Layer Ferrite				CV/CS201210	CF252016	CS321613	CF322513	CF453215

# Surface Mount Chip Inductor Capability Matrix



## Inductance Range

Model	Inductance range $\mu\text{H}$							
	0.001	0.01	0.1	1.0	10	100	1000	
CE201210				K				
CF252016				K				
CF322513				K				
CF453215				K				
CI160808	D	J						
CI201210	D	J						
CS201212				K				
CS321613				K				
CW160808		K	J					
CW201212			J					
CW252016		M	K	J				
CM100505	D	J						
CM160808	D	J						
CM201212			K					
CM252016			K					
CM322522			M		K			
CM453232			M		K			
CV201210				D	K	J		

D:  $\pm 0.3\text{nH}$   
 J:  $\pm 5\%$   
 K:  $\pm 10\%$   
 M:  $\pm 20\%$

## Frequency Range

Model	Frequency Range MHz (SRF)									
	0	5	10	50	100	500	1000	5000	10 GHz	15 GHz
CE201210							[Bar]			
CF252016				[Bar]						
CF322513				[Bar]						
CF453215				[Bar]						
CI160808						[Bar]				
CI201210						[Bar]				
CS201212				[Bar]						
CS321613				[Bar]						
CW160808							[Bar]			
CW201212							[Bar]			
CW252016						[Bar]				
CM100505							[Bar]			
CM160808							[Bar]			
CM201212						[Bar]				
CM252016				[Bar]						
CM322522			[Bar]							
CM453232		[Bar]								
CV201210				[Bar]						

# Surface Mount Chip Inductor Capability Matrix



## Current Range

Model	Current Range mA											
	0	100	200	300	400	500	600	700	800	900	1000	
CE201210	All values of CE201210 have a 300 mA current rating											
CF252016												
CF322513												
CF453215												
CI160808												
CI201210												
CS201212												
CS321613												
CW160808												
CW201212												
CW252016												
CM100505												
CM160808												
CM201212												
CM252016												
CM322522												
CM453232												
CV201210												1250

## Lab Kit Offering

Bourns Lab Kit Part Number	Product Size (mm)	Inductance Range	Values Per Kit	Quantity		E Series
				Per Value	Total	
CE201210-LAB1	2.0 x 1.25 x 1.25	0.047 $\mu$ H to 33 $\mu$ H	18	30	480	E12 / E6
CF252016-LAB1	2.5 x 2.0 x 1.6	0.1 $\mu$ H to 33 $\mu$ H	18	20	360	E12 / E6
CF322513-LAB1	3.2 x 2.5 x 1.3	0.12 $\mu$ H to 33 $\mu$ H	18	25	450	E12 / E6
CF453215-LAB1	4.5 x 3.2 x 1.5	0.1 $\mu$ H to 33 $\mu$ H	18	10	180	E12 / E6
CI160808-LAB1	1.6 x 0.8 x 0.8	1.0 nH to 220 nH	18	20	360	E12 / E6
CI201210-LAB1	2.0 x 1.25 x 1.0	1.0 nH to 220 nH	17	30	510	E6
CS201212-LAB1	2.0 x 1.25 x 1.25	47 nH to 33 $\mu$ H	18	30	540	E6
CS321613-LAB1	3.2 x 1.6 x 1.3	47 nH to 33 $\mu$ H	18	30	540	E6
CW160808-LAB1	1.6 x 0.8 x 0.8	4.7 nH to 220 nH	16	30	480	E12 / E6
CW201212-LAB1	2.1 x 1.5 x 1.3	2.2 nH to 910 nH	13	25	325	E6
CW252016-LAB1	2.75 x 2.6 x 2.0	10 nH to 4.7 $\mu$ H	17	20	340	E6
CM160808-LAB1	1.6 x 0.8 x 0.8	1.5 nH to 100 nH	18	30	540	E12
CM201212-LAB1	2.0 x 1.25 x 1.25	3.9 nH to 1.0 $\mu$ H	18	20	360	E 6
CM252016-LAB1	2.5 x 2.0 x 1.6	10 nH to 100 $\mu$ H	25	20	500	E 6
CM322522-LAB1	3.2 x 2.5 x 2.2	0.1 $\mu$ H to 220 $\mu$ H	21	10	210	E 6
CM453232-LAB1	4.5 x 3.2 x 3.2	0.1 $\mu$ H to 1000 $\mu$ H	25	10	250	E 6
CV201210-LAB1	2.0 x 1.25 x 1.25	1.5 $\mu$ H to 33 $\mu$ H	18	30	510	E12 / E6

## Soldering Profile

### Bourns Soldering Profile for Chip Inductors and Power Chokes

(Note: Profiles on Individual Data Sheets Supersede This Profile)

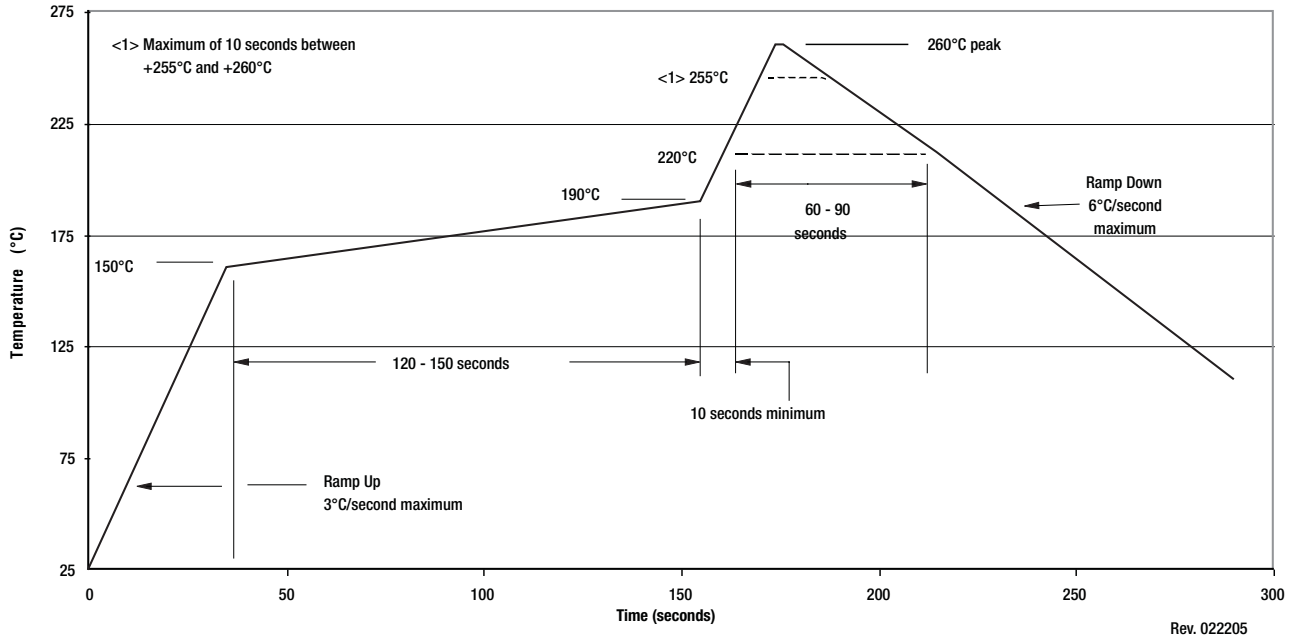

\*RoHS COMPLIANT

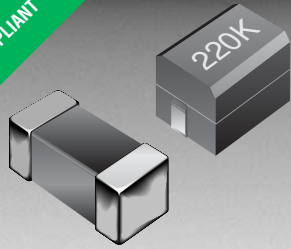

**BOURNS®**

## Features

- High resistance to heat and humidity
- Resistance to mechanical shock and pressure
- Accurate dimensions for automatic surface mounting
- Wide inductance range (1.0 nH to 1000 µH)
- RoHS compliant\*

## Applications

- Mobil phones
- Cellular phones
- CTV, VCR, HIC, FDD

## CM45, CM32, CM25, CM20, CM16, CM10 SMT Chip Inductors

### General Specifications

Temperature Rise .....	.....20 °C max.
Ambient Temperature .....	..... 80 °C max.
Operating Temperature	
CM10, CM16, CM20, CM25, CM32 .....	.....-40 °C to +100 °C
CM45 .....	.....-40 °C to +125 °C
Storage Temperature	
CM10, CM16, CM20, CM25, CM32 .....	.....-40 °C to +100 °C
CM45 .....	.....-40 °C to +125 °C
Resistance to Soldering Heat .....	.....260 °C, 5 seconds

### Materials

Core Material	
CM10, CM16 .....	.....Alumina Ceramic
CM20 .....	.....Polymer 10 nH to 1000 nH
CM25 .....	.....Polymer 10 nH to 180 nH
CM32 .....	.....Polymer 47 nH to 180 nH
Ferrite Core	
CM25 .....	.....220 nH to 100 µH
CM32 .....	.....220 nH +
CM45 .....	.....All
Coil Type	
CM10, CM16 .....	.....Copper plating
CM20, CM25, CM32, CM45 .....	.....Copper wire
Enclosure	
CM10, CM16 .....	.....Resin
CM20, CM25, CM32, CM45 .....	.....Epoxy resin
Terminal	
CM10, CM16, CM20, CM25, CM32, CM45 .....	.....Sn

### Product Dimensions

CM100505, CM160808

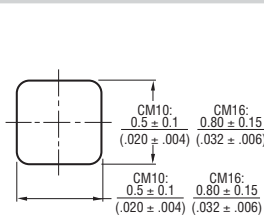
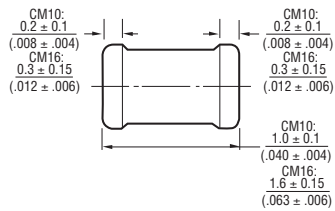

CM201212

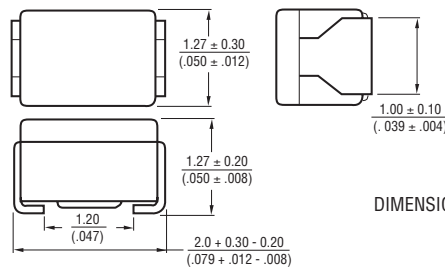

DIMENSIONS ARE:  $\frac{\text{MM}}{\text{(INCHES)}}$

CM252016

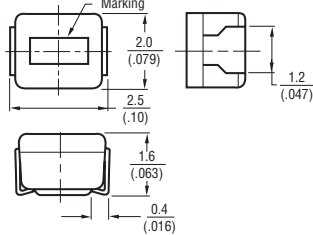

CM322522

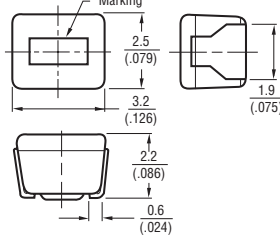

CM453232

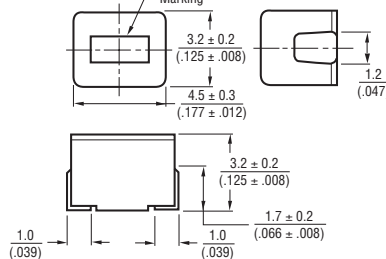

### Recommended Land Pattern Dimensions

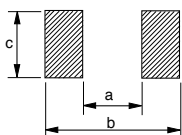

Model	a	b	c
CM10	0.5 to 0.6 (.019 to .023)	1.5 to 1.7 (.059 to .067)	0.5 to 0.6 (.019 to .023)
CM16	0.8 to 1.0 (.032 to .039)	2.0 to 2.6 (.079 to .102)	0.7 to 0.9 (.028 to .035)
CM20	1.0 to 1.2 (.039 to .047)	3.0 to 3.8 (.118 to .150)	0.9 to 1.3 (.028 to .051)
CM25	1.4 to 1.5 (.055 to .059)	3.5 to 4.0 (.138 to .157)	1.2 to 1.6 (.047 to .063)
CM32	1.6 to 2.0 (.063 to .079)	4.0 to 4.6 (.157 to .181)	1.9 to 2.4 (.075 to .094)
CM45	2.4 to 2.6 (.094 to .102)	5.5 to 6.0 (.217 to .236)	2.0 to 3.0 (.079 to .118)

\*RoHS Directive 2002/95/EC Jan 27 2003 including Annex Specifications are subject to change without notice. • Customers should verify actual device performance in their specific applications.



# CM45, CM32, CM25, CM20, CM16, CM10 SMT Chip Inductors

**BOURNS®**

## Packaging Specifications

### CM10

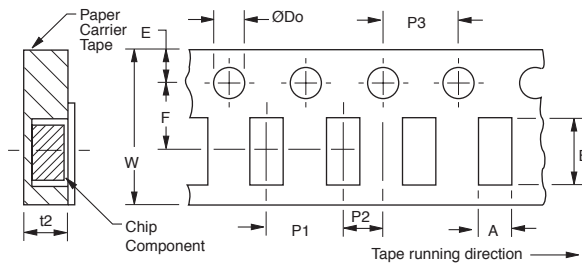

### CM16, CM20, CM25, CM32

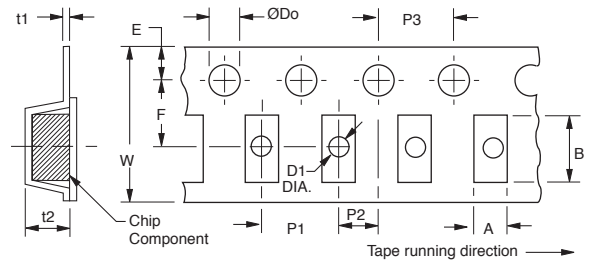

### CM45

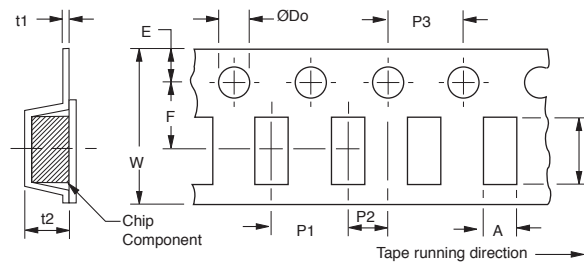

Model	A	B	W	F	E	P1	P2	P3	D0 Dia.	D1 Dia.	t1	t2
CM10	0.71 (.027)	1.21 (.047)	8.00 (.315)	3.50 (.138)	1.75 (.069)	4.00 (.157)	2.00 (.079)	4.00 (.157)	1.50 (.059)	—	—	0.66 (.026)
CM16	1.00 (.039)	1.80 (.071)	8.00 (.315)	3.50 (.138)	1.75 (.069)	4.00 (.157)	2.00 (.079)	4.00 (.157)	1.50 (.059)	0.60 (.024)	0.27 (.011)	1.20 (.047)
CM20	1.45 (.057)	2.25 (.089)	8.00 (.315)	3.50 (.138)	1.75 (.069)	4.00 (.157)	2.00 (.079)	4.00 (.157)	1.50 (.059)	1.00 (.039)	0.25 (.010)	1.55 (.061)
CM25	2.40 (.094)	2.90 (.114)	8.00 (.315)	3.50 (.138)	1.75 (.069)	4.00 (.157)	2.00 (.079)	4.00 (.157)	1.50 (.059)	1.10 (.043)	0.25 (.010)	1.85 (.073)
CM32	2.80 (.110)	3.60 (.142)	8.00 (.315)	3.50 (.138)	1.75 (.069)	4.00 (.157)	2.00 (.079)	4.00 (.157)	1.50 (.059)	—	0.25 (.010)	2.40 (.094)
CM45	3.60 (.142)	4.90 (.193)	12.00 (.472)	5.50 (.217)	1.75 (.069)	8.00 (.315)	2.00 (.079)	4.00 (.157)	1.50 (.059)	—	0.30 (.012)	3.50 (.138)

## Reel Dimensions

Model	A	B	C	D	E	W
CM10 ~ CM32	178 (7.008)	60 min.	13 (.512)	21 (.827)	2 (.079)	9 (.354)
CM45	178 (7.008)	60 min.	13 (.512)	21 (.827)	2 (.079)	13 (.512)

## Packaging

Model	Quantity	Weight
CM10	10000 pcs	150 g
CM16	3000 pcs	90 g
CM20	3000 pcs	90 g

Model	Quantity	Weight
CM25	2000 pcs	100 g
CM32	2000 pcs	190 g
CM45	500 pcs	100 g

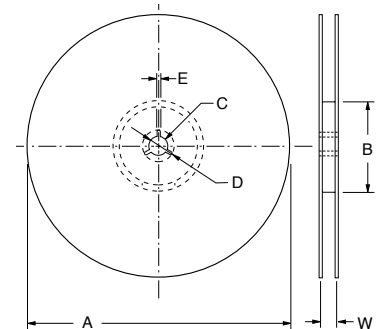

**Soldering Profiles**

**CM16, CM10**

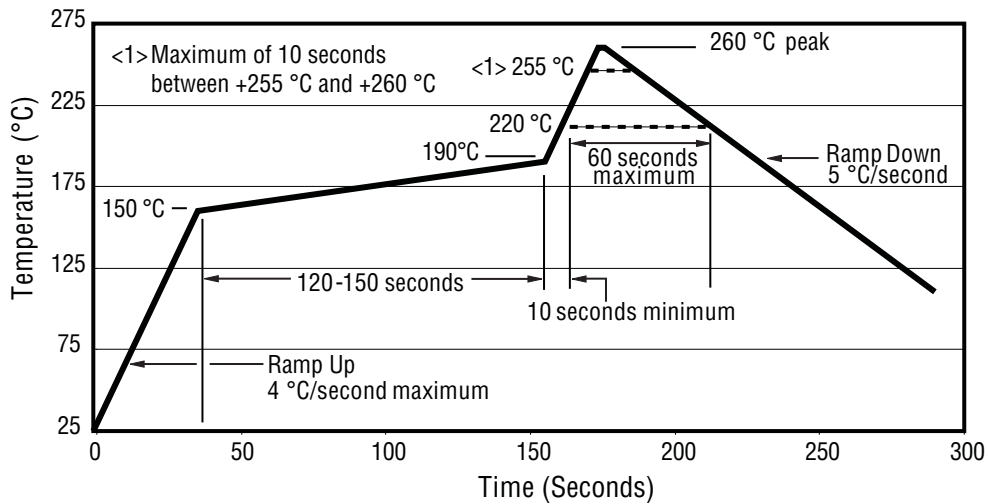

**CM45, CM32, CM25, CM20**

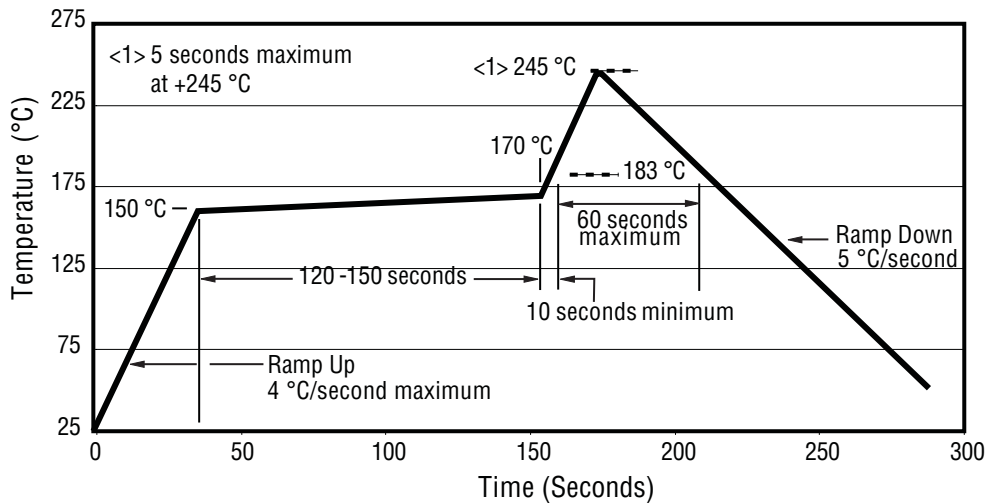

# Chip Inductors - CM453232 Series Wirewound

# BOURNS®

RoHS Compliant 1812 Size Part Number	Inductance μH	Std. Tolerance	Std. Tol. Code	1/2 Tolerance	1/2 Tol. Code	Q min.	Test Freq. MHz	SRF min. MHz	RDC ohm max	IDC mA max
CM453232-R10<1>L	0.10	±20 %	M	±10 %	K	35	25.2	300	0.18	800
CM453232-R12<1>L	0.12	±20 %	M	±10 %	K	35	25.2	280	0.2	770
CM453232-R15<1>L	0.15	±20 %	M	±10 %	K	35	25.2	250	0.22	730
CM453232-R18<1>L	0.18	±20 %	M	±10 %	K	35	25.2	220	0.24	700
CM453232-R22<1>L	0.22	±20 %	M	±10 %	K	40	25.2	200	0.25	665
CM453232-R27<1>L	0.27	±20 %	M	±10 %	K	40	25.2	180	0.26	635
CM453232-R33<1>L	0.33	±20 %	M	±10 %	K	40	25.2	165	0.28	605
CM453232-R39<1>L	0.39	±20 %	M	±10 %	K	40	25.2	150	0.30	575
CM453232-R47<1>L	0.47	±20 %	M	±10 %	K	40	25.2	145	0.32	545
CM453232-R56<1>L	0.56	±20 %	M	±10 %	K	40	25.2	140	0.36	520
CM453232-R68<1>L	0.68	±20 %	M	±10 %	K	40	25.2	135	0.40	500
CM453232-R82<1>L	0.82	±20 %	M	±10 %	K	40	25.2	130	0.45	475
CM453232-1R0<1>L	1.0	±10 %	K	±5 %	J	50	7.96	100	0.50	450
CM453232-1R2<1>L	1.2	±10 %	K	±5 %	J	50	7.96	80	0.55	430
CM453232-1R5<1>L	1.5	±10 %	K	±5 %	J	50	7.96	70	0.60	410
CM453232-1R8<1>L	1.8	±10 %	K	±5 %	J	50	7.96	60	0.65	390
CM453232-2R2<1>L	2.2	±10 %	K	±5 %	J	50	7.96	55	0.70	380
CM453232-2R7<1>L	2.7	±10 %	K	±5 %	J	50	7.96	50	0.75	370
CM453232-3R3<1>L	3.3	±10 %	K	±5 %	J	50	7.96	45	0.80	355
CM453232-3R9<1>L	3.9	±10 %	K	±5 %	J	50	7.96	40	0.90	330
CM453232-4R7<1>L	4.7	±10 %	K	±5 %	J	50	7.96	35	1.00	315
CM453232-5R6<1>L	5.6	±10 %	K	±5 %	J	50	7.96	33	1.10	300
CM453232-6R8<1>L	6.8	±10 %	K	±5 %	J	50	7.96	27	1.2	285
CM453232-8R2<1>L	8.2	±10 %	K	±5 %	J	50	7.96	25	1.4	270
CM453232-100<1>L	10	±10 %	K	±5 %	J	50	2.52	20	1.6	250
CM453232-120<1>L	12	±10 %	K	±5 %	J	50	2.52	18	2	225
CM453232-150<1>L	15	±10 %	K	±5 %	J	50	2.52	17	2.5	200
CM453232-180<1>L	18	±10 %	K	±5 %	J	50	2.52	15	2.8	190
CM453232-220<1>L	22	±10 %	K	±5 %	J	50	2.52	13	3.2	180
CM453232-270<1>L	27	±10 %	K	±5 %	J	50	2.52	12	3.6	170
CM453232-330<1>L	33	±10 %	K	±5 %	J	50	2.52	11	4	160
CM453232-390<1>L	39	±10 %	K	±5 %	J	50	2.52	10	4.5	150
CM453232-470<1>L	47	±10 %	K	±5 %	J	50	2.52	10	5	140
CM453232-560<1>L	56	±10 %	K	±5 %	J	50	2.52	9	5.5	135
CM453232-680<1>L	68	±10 %	K	±5 %	J	50	2.52	9	6	130
CM453232-820<1>L	82	±10 %	K	±5 %	J	50	2.52	8	7	120
CM453232-101<1>L	100	±10 %	K	±5 %	J	40	2.52	8	8	110
CM453232-121<1>L	120	±10 %	K	±5 %	J	40	0.796	6	8	110
CM453232-151<1>L	150	±10 %	K	±5 %	J	40	0.796	5	9	105
CM453232-181<1>L	180	±10 %	K	±5 %	J	40	0.796	5	9.5	102
CM453232-221<1>L	220	±10 %	K	±5 %	J	40	0.796	4	10	100
CM453232-271<1>L	270	±10 %	K	±5 %	J	40	0.796	4	12	92
CM453232-331<1>L	330	±10 %	K	±5 %	J	40	0.796	3.5	14	85
CM453232-391<1>L	390	±10 %	K	±5 %	J	40	0.796	3	18	80
CM453232-471<1>L	470	±10 %	K	±5 %	J	40	0.796	3	26	62
CM453232-561<1>L	560	±10 %	K	±5 %	J	30	0.796	3	30	50
CM453232-681<1>L	680	±10 %	K	±5 %	J	30	0.796	3	30	50
CM453232-821<1>L	820	±10 %	K	±5 %	J	30	0.796	2.5	35	30
CM453232-102<1>L	1000	±10 %	K	±5 %	J	30	0.252	2.5	40	30

<1> Enter tolerance code from standard or 1/2 tolerance column. Example: CM453232-1R2KL is standard tolerance; CM453232-1R2JL is 1/2 tolerance.

Specifications are subject to change without notice.  
Customers should verify actual device performance in their specific applications.

# Chip Inductors - CM322522 Series Wirewound

**BOURNS®**

RoHS Compliant 1210 Size Part Number	Inductance μH	Std. Tolerance	Std. Tol. Code	1/2 Tolerance	1/2 Tol. Code	Q min.	Test Freq. MHz	SRF min. MHz	RDC ohm max	IDC mA max
CM322522-47NML	0.047	±20 %	M	N/A	N/A	10	100	680	0.20	450
CM322522-56NML	0.056	±20 %	M	N/A	N/A	10	100	600	0.22	420
CM322522-68NML	0.068	±20 %	M	N/A	N/A	10	100	540	0.25	400
CM322522-82NML	0.082	±20 %	M	N/A	N/A	10	100	500	0.27	380
CM322522-R10ML	0.10	±20 %	M	N/A	N/A	10	100	450	0.30	360
CM322522-R12ML	0.12	±20 %	M	N/A	N/A	10	25.2	400	0.67	240
CM322522-R15ML	0.15	±20 %	M	N/A	N/A	10	25.2	350	0.72	230
CM322522-R18ML	0.18	±20 %	M	N/A	N/A	10	25.2	320	0.81	220
CM322522-R22<1>L	0.22	±20 %	M	±10 %	K	25	25.2	230	0.29	360
CM322522-R27<1>L	0.27	±20 %	M	±10 %	K	25	25.2	210	0.32	345
CM322522-R33<1>L	0.33	±20 %	M	±10 %	K	25	25.2	190	0.35	330
CM322522-R39<1>L	0.39	±20 %	M	±10 %	K	25	25.2	175	0.39	305
CM322522-R47<1>L	0.47	±20 %	M	±10 %	K	25	25.2	160	0.44	290
CM322522-R56<1>L	0.56	±20 %	M	±10 %	K	25	25.2	150	0.49	275
CM322522-R68<1>L	0.68	±20 %	M	±10 %	K	25	25.2	135	0.55	260
CM322522-R82<1>L	0.82	±20 %	M	±10 %	K	25	25.2	125	0.61	245
CM322522-1R0<1>L	1.0	±10 %	K	±5 %	J	30	7.96	115	0.69	230
CM322522-1R2<1>L	1.2	±10 %	K	±5 %	J	30	7.96	100	0.75	215
CM322522-1R5<1>L	1.5	±10 %	K	±5 %	J	30	7.96	90	0.75	210
CM322522-1R8<1>L	1.8	±10 %	K	±5 %	J	30	7.96	85	0.82	200
CM322522-2R2<1>L	2.2	±10 %	K	±5 %	J	30	7.96	80	0.95	190
CM322522-2R7<1>L	2.7	±10 %	K	±5 %	J	30	7.96	75	1.1	180
CM322522-3R3<1>L	3.3	±10 %	K	±5 %	J	30	7.96	65	1.2	180
CM322522-3R9<1>L	3.9	±10 %	K	±5 %	J	30	7.96	60	1.3	175
CM322522-4R7<1>L	4.7	±10 %	K	±5 %	J	30	7.96	55	1.5	165
CM322522-5R6<1>L	5.6	±10 %	K	±5 %	J	30	7.96	50	1.6	160
CM322522-6R8<1>L	6.8	±10 %	K	±5 %	J	30	7.96	45	1.8	150
CM322522-8R2<1>L	8.2	±10 %	K	±5 %	J	30	7.96	40	2.0	140
CM322522-100<1>L	10	±10 %	K	±5 %	J	30	2.52	36	2.1	140
CM322522-120<1>L	12	±10 %	K	±5 %	J	30	2.52	33	2.5	125
CM322522-150<1>L	15	±10 %	K	±5 %	J	30	2.52	30	2.8	120
CM322522-180<1>L	18	±10 %	K	±5 %	J	30	2.52	27	3.3	110
CM322522-220<1>L	22	±10 %	K	±5 %	J	30	2.52	25	3.7	105
CM322522-270<1>L	27	±10 %	K	±5 %	J	30	2.52	22	5.0	90
CM322522-330<1>L	33	±10 %	K	±5 %	J	30	2.52	20	5.6	85
CM322522-390<1>L	39	±10 %	K	±5 %	J	30	2.52	20	6.4	80
CM322522-470<1>L	47	±10 %	K	±5 %	J	30	2.52	15	7.0	75
CM322522-560<1>L	56	±10 %	K	±5 %	J	30	2.52	15	8.0	70
CM322522-680<1>L	68	±10 %	K	±5 %	J	30	2.52	15	9.0	65
CM322522-820<1>L	82	±10 %	K	±5 %	J	30	2.52	11	10	60
CM322522-101<1>L	100	±10 %	K	±5 %	J	20	0.796	10	10	60
CM322522-121<1>L	120	±10 %	K	±5 %	J	20	0.796	10	11	55
CM322522-151<1>L	150	±10 %	K	±5 %	J	20	0.796	8	15	50
CM322522-181<1>L	180	±10 %	K	±5 %	J	20	0.796	7	17	50
CM322522-221<1>L	220	±10 %	K	±5 %	J	20	0.796	7	21	45

Tighter tolerance available on request. Consult factory.

NOTE: 47 nH to 180 nH 'air core' / 220 nH to 220 μH 'ferrite core'

<1>Enter tolerance code from standard or 1/2 tolerance column. Example: CM322522-1R0KL is standard tolerance; CM322522-1R0JL is 1/2 tolerance.

Specifications are subject to change without notice.  
Customers should verify actual device performance in their specific applications.

# Chip Inductors - CM252016 Series Wirewound

**BOURNS®**

RoHS Compliant 1008 Size Part Number	Inductance μH	Tolerance	Q min.	Test Frequency MHz	SRF min. MHz	RDC ohm max	IDC mA max
CM252016-10NKL	0.010	±10 %	10	100	2500	0.32	280
CM252016-12NKL	0.012	±10 %	10	100	2200	0.34	270
CM252016-15NKL	0.015	±10 %	10	100	1800	0.38	255
CM252016-18NKL	0.018	±10 %	10	100	1550	0.4	250
CM252016-22NKL	0.022	±10 %	15	100	1350	0.43	240
CM252016-27NKL	0.027	±10 %	15	100	1150	0.47	230
CM252016-33NKL	0.033	±10 %	15	100	1000	0.51	220
CM252016-39NKL	0.039	±10 %	15	100	890	0.55	215
CM252016-47NKL	0.047	±10 %	15	100	770	0.59	205
CM252016-56NKL	0.056	±10 %	15	100	670	0.63	200
CM252016-68NKL	0.068	±10 %	15	100	590	0.68	190
CM252016-82NKL	0.082	±10 %	15	100	520	0.73	185
CM252016-R10KL	0.10	±10 %	10	25.2	460	0.80	175
CM252016-R12KL	0.12	±10 %	10	25.2	400	0.87	170
CM252016-R15KL	0.15	±10 %	10	25.2	340	0.98	160
CM252016-R18KL	0.18	±10 %	10	25.2	300	1.05	155
CM252016-R22ML	0.22	±20 %	25	25.2	230	0.70	190
CM252016-R27ML	0.27	±20 %	25	25.2	210	0.75	180
CM252016-R33ML	0.33	±20 %	25	25.2	190	0.85	170
CM252016-R39ML	0.39	±20 %	25	25.2	175	0.95	160
CM252016-R47ML	0.47	±20 %	25	25.2	160	1.00	155
CM252016-R56ML	0.56	±20 %	25	25.2	150	1.10	150
CM252016-R68ML	0.68	±20 %	25	25.2	135	1.25	140
CM252016-R82ML	0.82	±20 %	25	25.2	125	1.40	130
CM252016-1R0KL	1.0	±10 %	25	7.96	115	0.65	195
CM252016-1R2KL	1.2	±10 %	25	7.96	100	0.75	180
CM252016-1R5KL	1.5	±10 %	25	7.96	90	0.85	170
CM252016-1R8KL	1.8	±10 %	25	7.96	85	0.95	160
CM252016-2R2KL	2.2	±10 %	25	7.96	80	1.05	155
CM252016-2R7KL	2.7	±10 %	25	7.96	75	1.2	145
CM252016-3R3KL	3.3	±10 %	25	7.96	65	1.3	135
CM252016-3R9KL	3.9	±10 %	25	7.96	60	1.4	130
CM252016-4R7KL	4.7	±10 %	25	7.96	55	1.6	125
CM252016-5R6KL	5.6	±10 %	25	7.96	50	1.8	120
CM252016-6R8KL	6.8	±10 %	25	7.96	45	1.9	115
CM252016-8R2KL	8.2	±10 %	25	7.96	40	2.2	105
CM252016-100KL	10	±10 %	25	2.52	32	3.5	80
CM252016-120KL	12	±10 %	25	2.52	30	3.8	75
CM252016-150KL	15	±10 %	25	2.52	28	4.4	70
CM252016-180KL	18	±10 %	25	2.52	25	5.0	65
CM252016-220KL	22	±10 %	25	2.52	22	5.8	60
CM252016-270KL	27	±10 %	20	2.52	21	6.3	115
CM252016-330KL	33	±10 %	20	2.52	20	7.1	110
CM252016-390KL	39	±10 %	20	2.52	18	9.5	90
CM252016-470KL	47	±10 %	20	2.52	17	11.0	80
CM252016-560KL	56	±10 %	20	2.52	16	12.1	75
CM252016-680KL	68	±10 %	20	2.52	15	16.6	70
CM252016-820KL	82	±10 %	20	2.52	13	19.0	65
CM252016-101KL	100	±10 %	15	0.796	12	21.0	60

Tighter tolerance available on request. Consult factory.

NOTE: 10 nH to 180 nH 'air core' / 220 nH to 220 uH 'ferrite core'

Specifications are subject to change without notice.

Customers should verify actual device performance in their specific applications.

# Chip Inductors - CM201212 Series Wirewound

**BOURNS®**

RoHS Compliant 0805 Size Part Number	Inductance $\mu$ H	Tolerance	Q min.	Test Frequency MHz	SRF min. MHz	RDC ohm max	IDC mA max
CM201212-10NKL	0.010	$\pm 10$ %	10	100	3300	0.20	540
CM201212-12NKL	0.012	$\pm 10$ %	10	100	3300	0.23	535
CM201212-15NKL	0.015	$\pm 10$ %	12	100	3000	0.25	520
CM201212-18NKL	0.018	$\pm 10$ %	12	100	3000	0.27	480
CM201212-22NKL	0.022	$\pm 10$ %	15	100	2600	0.29	465
CM201212-27NKL	0.027	$\pm 10$ %	15	100	2500	0.32	455
CM201212-33NKL	0.033	$\pm 10$ %	15	100	2000	0.37	395
CM201212-39NKL	0.039	$\pm 10$ %	15	100	2000	0.38	390
CM201212-47NKL	0.047	$\pm 10$ %	15	100	1600	0.42	385
CM201212-56NKL	0.056	$\pm 10$ %	15	100	1500	0.45	360
CM201212-68NKL	0.068	$\pm 10$ %	15	100	1400	0.52	340
CM201212-82NKL	0.082	$\pm 10$ %	15	100	1100	0.60	330
CM201212-R10KL	0.10	$\pm 10$ %	8	25.2	800	0.78	285
CM201212-R12KL	0.12	$\pm 10$ %	8	25.2	600	0.99	275
CM201212-R15KL	0.15	$\pm 10$ %	10	25.2	600	1.47	230
CM201212-R18KL	0.18	$\pm 10$ %	10	25.2	600	1.61	195
CM201212-R22KL	0.22	$\pm 10$ %	10	25.2	500	1.84	170
CM201212-R27KL	0.27	$\pm 10$ %	10	25.2	300	1.95	165
CM201212-R33KL	0.33	$\pm 10$ %	10	25.2	200	2.16	160
CM201212-R39KL	0.39	$\pm 10$ %	10	25.2	150	2.35	150
CM201212-R47KL	0.47	$\pm 10$ %	10	25.2	150	2.57	145
CM201212-R56KL	0.56	$\pm 10$ %	10	25.2	100	2.65	140
CM201212-R68KL	0.68	$\pm 10$ %	10	25.2	100	2.99	130
CM201212-R82KL	0.82	$\pm 10$ %	10	25.2	80	3.35	125
CM201212-1R0KL	1.0	$\pm 10$ %	8	7.96	80	3.82	120

Tighter tolerance available on request. Consult factory.

# Chip Inductors - CM160808 Series Laser-cut Winding

**BOURNS®**

RoHS Compliant 0603 Size Part Number	Inductance nH	Tolerance	Q min.	Test Frequency MHz	SRF min. MHz	RDC ohm max	IDC mA max
CM160808-1N5DL	1.5	± 0.3 nH	8	100	6000	0.07	500
CM160808-1N8DL	1.8	± 0.3 nH	8	100	6000	0.08	500
CM160808-2N2DL	2.2	± 0.3 nH	8	100	6000	0.09	500
CM160808-2N7DL	2.7	± 0.3 nH	8	100	6000	0.10	500
CM160808-3N3DL	3.3	± 0.3 nH	9	100	5500	0.12	500
CM160808-3N9JL	3.9	±5 %	9	100	5500	0.15	450
CM160808-4N7JL	4.7	±5 %	9	100	4800	0.17	450
CM160808-5N6JL	5.6	±5 %	9	100	4600	0.18	430
CM160808-6N8JL	6.8	±5 %	9	100	3550	0.20	430
CM160808-8N2JL	8.2	±5 %	9	100	3500	0.28	400
CM160808-10N1JL	10	±5 %	10	100	2800	0.32	400
CM160808-12N1JL	12	±5 %	10	100	2800	0.35	400
CM160808-15N1JL	15	±5 %	10	100	2500	0.41	350
CM160808-18N1JL	18	±5 %	10	100	2300	0.45	350
CM160808-22N1JL	22	±5 %	10	100	2000	0.50	300
CM160808-27N1JL	27	±5 %	10	100	2000	0.55	300
CM160808-33N1JL	33	±5 %	10	100	1800	0.60	300
CM160808-39N1JL	39	±5 %	11	100	1800	0.80	300
CM160808-47N1JL	47	±5 %	11	100	1800	0.95	250
CM160808-56N1JL	56	±5 %	12	100	1800	1.2	250
CM160808-68N1JL	68	±5 %	12	100	1500	1.3	250
CM160808-82N1JL	82	±5 %	12	100	1500	1.5	250
CM160808-R10JL	100	±5 %	12	100	1300	1.8	200
CM160808-R12JL	120	±5 %	5	25.2	1200	3.0	130
CM160808-R15JL	150	±5 %	5	25.2	1100	4.5	100
CM160808-R18JL	180	±5 %	4	25.2	1000	6.5	80
CM160808-R22JL	220	±5 %	4	25.2	900	7.5	70

Specifications are subject to change without notice.  
Customers should verify actual device performance in their specific applications.

# Chip Inductors - CM100505 Series Laser-cut Winding

**BOURNS®**

Lead Free 0402 Size Part Number	Inductance nH	Tolerance	Q min.	Test Frequency MHz	SRF min. MHz	RDC ohm max	IDC mA max
CM100505-1N0DL	1.00	±0.3 nH	8	100	6000	0.05	400
CM100505-1N2DL	1.20	±0.3 nH	8	100	6000	0.06	400
CM100505-1N5DL	1.50	±0.3 nH	8	100	6000	0.07	400
CM100505-1N8DL	1.80	±0.3 nH	8	100	6000	0.08	400
CM100505-2N2DL	2.20	±0.3 nH	8	100	6000	0.09	400
CM100505-2N7DL	2.70	±0.3 nH	8	100	5500	0.10	400
CM100505-3N3DL	3.30	±0.3 nH	8	100	5500	0.12	400
CM100505-3N9DL	3.90	±0.3 nH	8	100	5200	0.15	360
CM100505-4N7DL	4.70	±0.3 nH	8	100	4800	0.17	360
CM100505-5N6DL	5.60	±0.3 nH	8	100	4600	0.19	340
CM100505-6N8JL	6.80	± 5 %	8	100	4000	0.30	320
CM100505-8N2JL	8.20	± 5 %	8	100	3500	0.35	320
CM100505-10NJL	10.00	± 5 %	8	100	2800	0.41	320
CM100505-12NJL	12.00	± 5 %	8	100	2800	0.45	320
CM100505-15NJL	15.00	± 5 %	8	100	2500	0.60	240
CM100505-18NJL	18.00	± 5 %	8	100	2200	0.70	240
CM100505-22NJL	22.00	± 5 %	8	100	2000	0.80	200
CM100505-27NJL	27.00	± 5 %	8	100	1800	1.2	200
CM100505-33NJL	33.00	± 5 %	8	100	1800	1.4	170
CM100505-39NJL	39.00	± 5 %	8	100	1800	1.7	150
CM100505-47NJL	47.00	± 5 %	8	100	1800	2.1	140



\*RoHS COMPLIANT

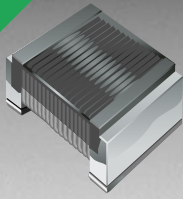

**BOURNS®**

## Features

- 1008 size
- Available in E12 series
- High Q up to 80 typ.
- High operating temperature of 125 °C
- Lead free

## Applications

- Mobil phones
- Cellular phones
- CTV, VCR, HIC, FDD

# CW252016 Series - High Q Chip Inductors

## Electrical Specifications

Bourns Part No.	Inductance		Q	Test Freq. MHz		SRF min.	RDC	I rms
	nH	Tol.%		L	Q			
CW252016-10NK	10	±10	50	100	500	4100	0.08	600
CW252016-12NK	12	±10	50	100	500	3300	0.08	600
CW252016-15NK	15	±10	40	100	350	2500	0.08	500
CW252016-18NK	18	±10	50	100	350	2500	0.10	600
CW252016-22NK	22	±10	55	100	350	2400	0.10	600
CW252016-27NK	27	±10	55	100	350	1600	0.10	600
CW252016-33NK	33	±10	60	100	350	1600	0.10	600
CW252016-39NK	39	±10	60	100	350	1500	0.10	600
CW252016-47NK	47	±10	60	100	350	1500	0.10	600
CW252016-56NJ	56	±5	60	100	350	1300	0.12	600
CW252016-68NJ	68	±5	60	100	350	1300	0.15	600
CW252016-82NJ	82	±5	60	100	350	1000	0.18	600
CW252016-R10J	100	±5	60	100	350	1000	0.18	500
CW252016-R12J	120	±5	50	25	100	950	0.20	500
CW252016-R15J	150	±5	45	25	100	850	0.22	500
CW252016-R18J	180	±5	45	25	100	750	0.33	500
CW252016-R22J	220	±5	45	25	100	700	0.45	500
CW252016-R27J	270	±5	45	25	100	600	0.75	500
CW252016-R33J	330	±5	45	25	100	570	0.90	500
CW252016-R39J	390	±5	45	25	100	500	1.20	400
CW252016-R47J	470	±5	45	25	100	450	1.19	470
CW252016-R56J	560	±5	45	25	100	415	1.33	400
CW252016-R68J	680	±5	45	25	100	375	1.47	400
CW252016-R82J	820	±5	45	25	100	350	1.61	360
CW252016-1R0J	1000	±5	25	25	50	290	1.75	330
CW252016-1R2J	1200	±5	25	7.9	7.9	250	2.00	280
CW252016-1R5J	1500	±5	25	7.9	7.9	200	2.30	280
CW252016-1R8J	1800	±5	25	7.9	7.9	160	2.60	270
CW252016-2R2J	2200	±5	25	7.9	7.9	160	2.80	250
CW252016-2R7J	2700	±5	22	7.9	7.9	70	1.70	195
CW252016-3R3J	3300	±5	22	7.9	7.9	55	1.90	185
CW252016-3R9J	3900	±5	20	7.9	7.9	48	2.10	180
CW252016-4R7J	4700	±5	18	7.9	7.9	43	2.30	175
CW252016-5R6J	5600	±5	18	7.9	7.9	40	4.90	180
CW252016-6R8J	6800	±5	18	7.9	7.9	25	6.00	150
CW252016-8R2J	8200	±5	18	7.9	7.9	25	8.00	100
CW252016-100J	10000	±5	18	2.5	7.9	40	4.20	200

## Packaging Specifications

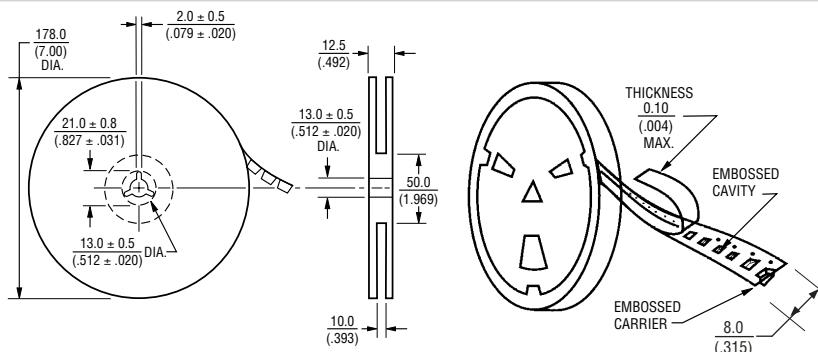

## General Specifications

Temperature Rise  
 .....40 °C max. at rated current  
 Operating Temperature  
 .....-40 °C to +125 °C  
 Storage Temperature...-40 °C to +125 °C  
 Reflow Soldering ...230 °C, 50 sec. max.  
 Resistance to Soldering Heat  
 .....260 °C, 5 seconds

## Materials

Core Material  
 -10NK thru -R82J .....Ceramic  
 -1R0J thru -4R7J .....Ferrite  
 Wire .....Enamelled Copper (1W1E180)  
 Terminal.....Mo/Mn+Ni+Au  
 Packaging.....2,000 pcs per reel

## Product Dimensions

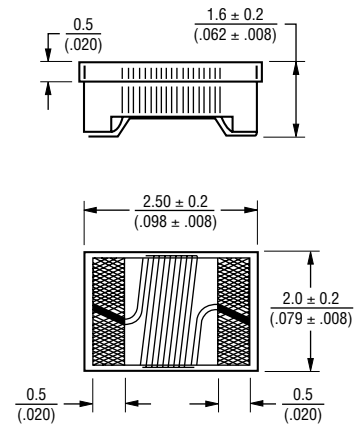

## Recommended Layout

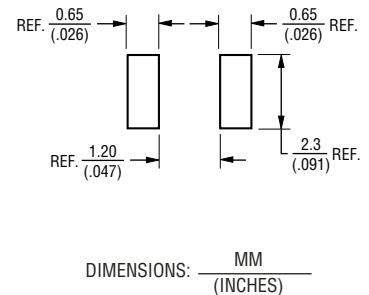

NOTE: 2% TOLERANCE AVAILABLE FOR INDUCTANCE RANGES OF 33 NH AND UP. REPLACE "J" OR "K" WITH "G".

REV. 10/08

\*RoHS Directive 2002/95/EC Jan 27 2003 including Annex Specifications are subject to change without notice. Customers should verify actual device performance in their specific applications.

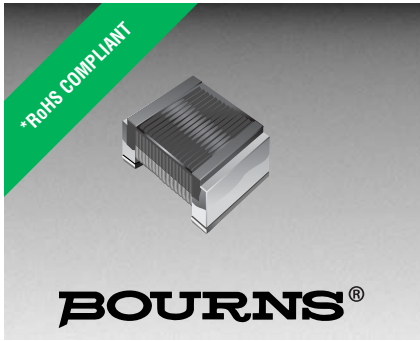

### Features

- 0805 size
- Available in E12 series
- High Q up to 80 typ.
- High operating temperature of 125 °C
- Small size of only 2.0 mm
- Lead Free

### Applications

- Mobil phones
- Cellular phones
- CTV, VCR, HIC, FDD

## CW201212 Series - High Q Chip Inductors

### Electrical Specifications

Bourns Part No.	Inductance		Q	Test Freq. MHz		SRF min. MHz	RDC ohms	I rms mA max.
	nH	Tol. %		L	Q			
CW201212-2N2J	2.2	±5	50	250	1000	6000	0.06	600
CW201212-2N7J	2.7	±5	35	250	1000	6000	0.08	600
CW201212-2N8J	2.8	±5	32	250	1000	6000	0.06	800
CW201212-3N3J	3.3	±5	30	250	1500	6000	0.08	600
CW201212-3N9J	3.9	±5	60	250	1000	6000	0.06	600
CW201212-4N7J	4.7	±5	60	250	1000	5800	0.06	600
CW201212-5N6J	5.6	±5	60	250	1000	5800	0.08	600
CW201212-6N8J	6.8	±5	60	250	1000	5800	0.06	600
CW201212-8N2J	8.2	±5	60	250	1000	5500	0.06	600
CW201212-10N1J	10	±5	60	250	500	4800	0.08	600
CW201212-12N1J	12	±5	60	250	500	4100	0.08	600
CW201212-15N1J	15	±5	60	250	500	3600	0.08	600
CW201212-18N1J	18	±5	60	250	500	3400	0.08	600
CW201212-22N1J	22	±5	60	250	500	3300	0.10	600
CW201212-27N1J	27	±5	60	250	500	2600	0.12	600
CW201212-33N1J	33	±5	60	250	500	2400	0.15	500
CW201212-39N1J	39	±5	60	250	500	2100	0.18	500
CW201212-47N1J	47	±5	60	200	500	1700	0.15	500
CW201212-56N1J	56	±5	60	200	500	1600	0.25	500
CW201212-68N1J	68	±5	60	200	500	1450	0.27	500
CW201212-82N1J	82	±5	60	150	500	1350	0.32	500
CW201212-R10J	100	±5	60	150	500	1200	0.43	400
CW201212-R12J	120	±5	50	150	250	1100	0.48	400
CW201212-R15J	150	±5	50	100	250	950	0.67	400
CW201212-R18J	180	±5	50	100	250	900	0.85	350
CW201212-R22J	220	±5	50	100	250	860	1.10	300
CW201212-R27J	270	±5	45	100	250	850	1.46	250
CW201212-R33J	330	±5	45	100	250	800	1.65	200
CW201212-R39J	390	±5	45	100	250	780	2.20	170
CW201212-R47J	470	±5	33	250	100	375	1.72	250
CW201212-R56J	560	±5	23	50	50	340	1.90	230
CW201212-R68J	680	±5	23	25	50	270	2.05	190
CW201212-R82J	820	±5	23	25	50	230	2.30	180
CW201212-R91J	910	±5	22	22	50	220	2.50	150

### General Specifications

Temperature Rise .....40 °C max. at rated current  
 Operating Temperature .....-40 °C to +125 °C  
 Storage Temperature...-40 °C to +125 °C  
 Reflow Soldering ...230 °C, 50 sec. max.  
 Resistance to Soldering Heat .....260 °C, 5 seconds

### Materials

Core Material  
 -2N2J through -R39J .....Ceramic  
 -R47J through -R91J.....Ferrite  
 Wire .....Enamelled Copper (1W1E180)  
 Terminal.....Mo/Mn+Ni+Au  
 Packaging.....2,000 pcs. per reel

### Product Dimensions

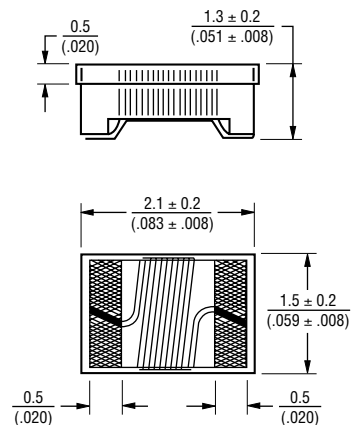

### Packaging Specifications

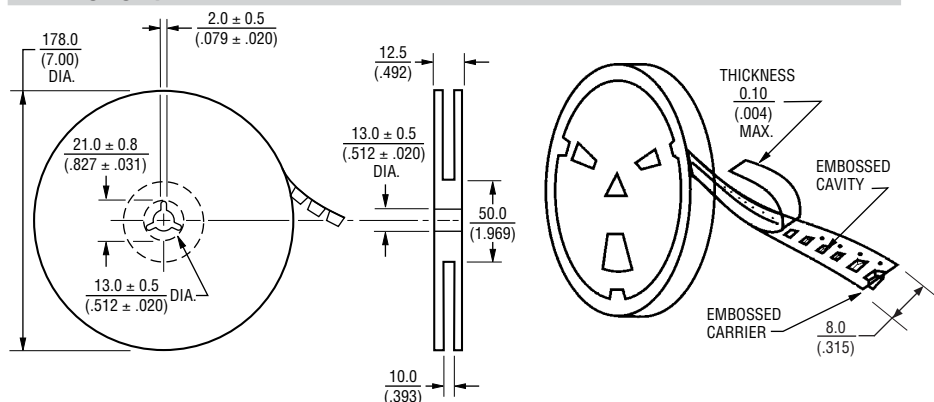

### Recommended Layout

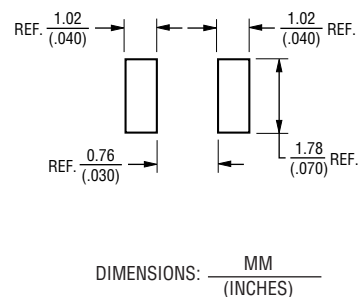

NOTE: 2 % TOLERANCE AVAILABLE FOR INDUCTANCE RANGES OF 12 NH AND UP. REPLACE "J" WITH "G".

\*RoHS Directive 2002/95/EC Jan 27 2003 including Annex Specifications are subject to change without notice. Customers should verify actual device performance in their specific applications.

\*RoHS COMPLIANT

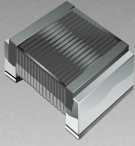

**BOURNS®**

## Features

- 0603 size
- Available in E12 series
- High Q up to 80 typ.
- High operating temperature of 125 °C
- Small size of only 1.6 mm
- Lead free

## Applications

- Mobil phones
- Cellular phones
- CTV, VCR, HIC, FDD

# CW160808 Series - High Q Chip Inductors

## Electrical Specifications

Bourns Part No.	Inductance		Q	Test Freq. MHz		SRF min.	RDC	I rms
	nH	Tol. %		L	Q			
CW160808-1N8M	1.8	±20	16	250	250	6000	0.04	700
CW160808-2N2D	2.2	±15	16	250	250	6000	0.08	700
CW160808-3N9K	3.9	±10	16	250	250	6000	0.08	700
CW160808-4N7K	4.7	±10	16	250	250	5800	0.10	700
CW160808-6N8J	6.8	±5	25	250	250	5800	0.11	700
CW160808-8N2J	8.2	±5	30	250	250	5000	0.11	700
CW160808-10NJ	10	±5	30	250	250	4800	0.13	700
CW160808-12NJ	12	±5	30	250	250	4000	0.13	700
CW160808-15NJ	15	±5	30	250	250	4000	0.17	700
CW160808-18NJ	18	±5	30	250	250	3100	0.17	700
CW160808-22NJ	22	±5	35	250	250	3000	0.19	700
CW160808-27NJ	27	±5	35	250	250	2800	0.22	600
CW160808-33NJ	33	±5	35	250	250	2300	0.22	600
CW160808-39NJ	39	±5	35	250	250	2200	0.25	600
CW160808-47NJ	47	±5	35	200	250	2100	0.28	600
CW160808-56NJ	56	±5	35	200	250	1900	0.31	600
CW160808-68NJ	68	±5	35	200	250	1700	0.34	600
CW160808-72NJ	72	±5	34	200	250	1700	0.49	400
CW160808-82NJ	82	±5	34	150	250	1700	0.54	400
CW160808-R10J	100	±5	34	150	250	1400	0.71	400
CW160808-R12J	120	±5	32	150	250	1350	0.79	300
CW160808-R15J	150	±5	28	150	150	1300	0.92	280
CW160808-R18J	180	±5	25	100	100	990	1.25	240
CW160808-R22J	220	±5	25	100	100	990	1.90	200
CW160808-R27J	270	±5	25	100	100	990	2.30	170

## Packaging Specifications

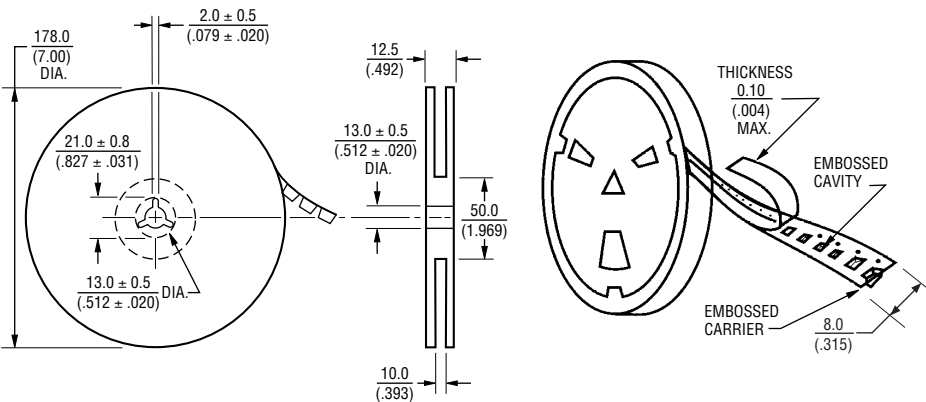

## General Specifications

Temperature Rise .....20 °C max. at rated current  
 Operating Temperature .....-40 °C to +125 °C  
 Storage Temperature .....-40 °C to +125 °C  
 Reflow Soldering ...230 °C, 50 sec. max.  
 Resistance to Soldering Heat .....260 °C, 10 seconds

## Materials

Core Material .....Alumina (1CC150707-302291)  
 Wire .....Enamelled Copper (1W1E180)  
 Terminal.....Mo/Mn+Ni+Au  
 Encapsulate Epoxy (1EAS-UV300)  
 Packaging.....3,000 pcs per reel

## Product Dimensions

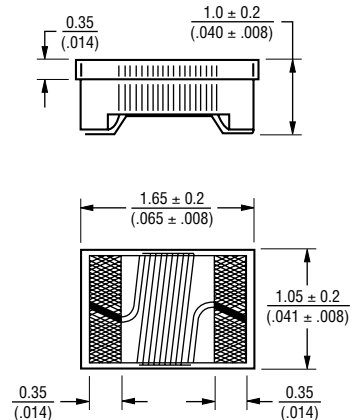

## Recommended Layout

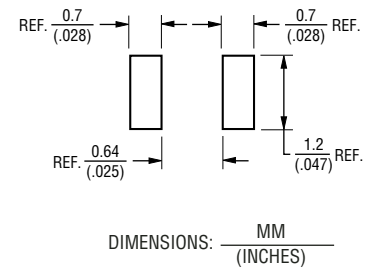

REV. 10/08

\*RoHS Directive 2002/95/EC Jan 27 2003 including Annex  
 Specifications are subject to change without notice.  
 Customers should verify actual device performance in their specific applications.

\*RoHS COMPLIANT

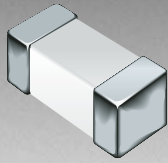

**BOURNS®**

**Features**

- 0805 size
- Available in E12 Series
- High frequency
- Nickel barrier
- Lead free

**Applications**

- Mobil phones
- Cellular phones
- CTV, VCR, HIC, FDD
- Automotive electronics

**CE201210 Series - Multi-Layer Chip Inductors**

**Electrical Specifications**

Bourns Part No.	Inductance		Q typ.	Test Freq.	SRF MHz	DCR	I rms
	nH	Tol. %	(@ 100 MHz)	L MHz	min.	mohm max.	mA max.
CE201210-1N5D	1.5	± 0.3 nH	21	100	4000	100	300
CE201210-1N8D	1.8	± 0.3 nH	18	100	4000	100	300
CE201210-2N2D	2.2	± 0.3 nH	18	100	4000	100	300
CE201210-2N7D	2.7	± 0.3 nH	19	100	4000	100	300
CE201210-3N3J	3.3	± 5	16	100	4000	130	300
CE201210-3N9J	3.9	± 5	18	100	4000	150	300
CE201210-4N7J	4.7	± 5	18	100	3500	200	300
CE201210-5N6J	5.6	± 5	20	100	3200	230	300
CE201210-6N8J	6.8	± 5	20	100	2800	250	300
CE201210-8N2J	8.2	± 5	21	100	2400	280	300
CE201210-10NJ	10	± 5	20	100	2100	300	300
CE201210-12NJ	12	± 5	21	100	1900	350	300
CE201210-15NJ	15	± 5	22	100	1600	400	300
CE201210-18NJ	18	± 5	24	100	1500	450	300
CE201210-22NJ	22	± 5	23	100	1400	500	300
CE201210-27NJ	27	± 5	23	100	1300	550	300
CE201210-33NJ	33	± 5	24	100	1200	600	300
CE201210-39NJ	39	± 5	23	100	1000	650	300
CE201210-47NJ	47	± 5	23	100	900	700	300
CE201210-56NJ	56	± 5	23	100	800	750	300
CE201210-68NJ	68	± 5	25	100	700	800	300
CE201210-82NJ	82	± 5	24	100	600	900	300
CE201210-R10J	100	± 5	23	100	600	900	300
CE201210-R12J	120	± 5	22	50	500	950	300
CE201210-R15J	150	± 5	22	50	500	1000	300
CE201210-R18J	180	± 5	23	50	400	1100	300
CE201210-R22J	220	± 5	20	50	350	1200	300
CE201210-R27J	270	± 5	20	50	300	1300	300
CE201210-R33J	330	± 5	22	50	250	1400	300
CE201210-R39J	390	± 5	17	50	250	1300	300
CE201210-R47J	470	± 5	17	50	200	1500	300

**General Specifications**

Temperature Rise .....30 °C max. at rated current  
 Operating Temperature ..-55 °C to +125 °C  
 Storage Temperature...-55 °C to +125 °C  
 Reflow Soldering ...230 °C, 50 sec. max.  
 Resistance to Soldering Heat .....260 °C, 10 seconds

**Materials**

Base Material .....Ceramic  
 Terminal.....Ag/Ni/Sn  
 Packaging:  
 0.85 mm product height .....4,000 pcs. per reel  
 1.00 mm product height .....4,000 pcs. per reel  
 1.25 mm product height .....2,000 pcs. per reel

**Product Dimensions**

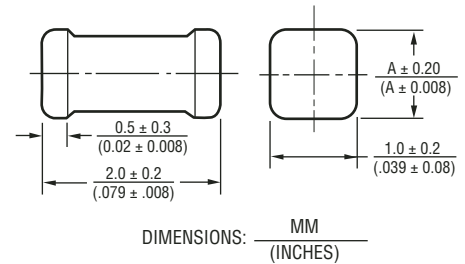

Model	Dimension A
CE201210-1N5D through CE201210-82NJ	0.85 (0.033)
CE201210-R10J through CE201210-R39J	1.00 (0.039)
CE201210-R47J	1.25 (0.050)

**Packaging Specifications**

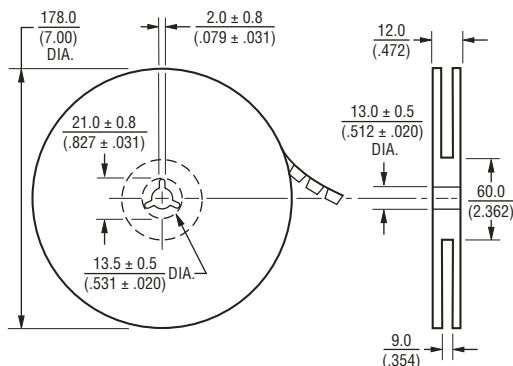

**Recommended Layout**

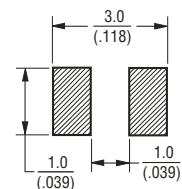

\*RoHS Directive 2002/95/EC Jan 27 2003 including Annex Specifications are subject to change without notice. Customers should verify actual device performance in their specific applications.

# CE201210 Series - Multi-Layer Chip Inductors

**BOURNS®**

## Electrical Specifications

**Q Characteristics**

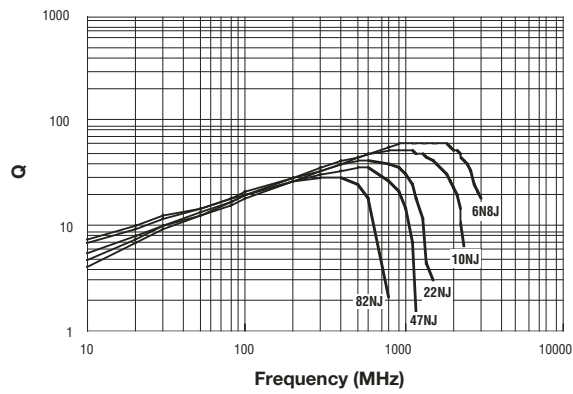

**DC Bias Characteristics**

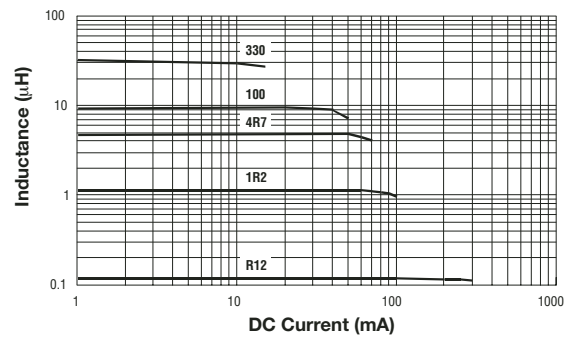

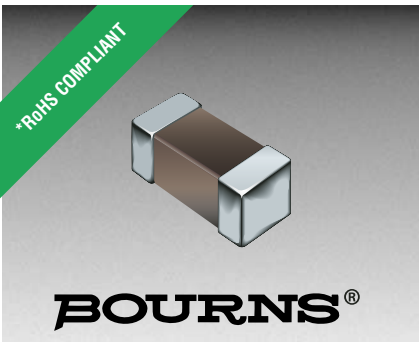

### Features

- 0805 size
- Magnetic shielding
- Height as low as 0.85 mm
- Nickel barrier
- Lead free

### Applications

- Prevention of electromagnetic interference to signals on the secondary side of electronic equipment

## CV201210 Series - Ferrite Multi-Layer Chip Inductors

### Electrical Specifications

Bourns Part No.	Inductance		Q	Test Freq.	SRF MHz	DCR	I rms
	μH	Tol. %					
CV201210-47NK	0.047	± 10	15	50*	320	200	300
CV201210-68NK	0.068	± 10	15	50	280	200	300
CV201210-82NK	0.082	± 10	15	50	255	200	300
CV201210-R10K	0.10	± 10	20	25	235	300	250
CV201210-R12K	0.12	± 10	20	25	220	300	250
CV201210-R15K	0.15	± 10	20	25	200	400	250
CV201210-R18K	0.18	± 10	20	25	185	400	250
CV201210-R22K	0.22	± 10	20	25	170	500	250
CV201210-R27K	0.27	± 10	20	25	150	500	250
CV201210-R33K	0.33	± 10	20	25	145	550	250
CV201210-R39K	0.39	± 10	25	25	135	650	200
CV201210-R47K	0.47	± 10	25	25	125	650	200
CV201210-R56K	0.56	± 10	25	25	115	750	150
CV201210-R68K	0.68	± 10	25	25	105	800	150
CV201210-R82K	0.82	± 10	25	25	100	1000	150
CV201210-1R0K	1.0	± 10	45	10	75	400	50
CV201210-1R2K	1.2	± 10	45	10	65	500	50
CV201210-1R5K	1.5	± 10	45	10	60	500	50
CV201210-1R8K	1.8	± 10	45	10	55	600	50
CV201210-2R2K	2.2	± 10	45	10	50	650	30
CV201210-2R7K	2.7	± 10	45	10	45	750	30
CV201210-3R3K	3.3	± 10	45	10	41	800	30
CV201210-3R9K	3.9	± 10	45	10	38	900	30
CV201210-4R7K	4.7	± 10	45	10	35	1000	30
CV201210-5R6K	5.6	± 10	45	4	32	900	15
CV201210-6R8K	6.8	± 10	45	4	29	1000	15
CV201210-8R2K	8.2	± 10	45	4	26	1100	15
CV201210-100K	10	± 10	45	2	24	1150	15
CV201210-120K	12	± 10	45	2	22	1250	5
CV201210-150K	15	± 10	30	1	19	800	5
CV201210-180K	18	± 10	30	1	18	900	5
CV201210-220K	22	± 10	30	1	16	1100	5
CV201210-270K	27	± 10	30	1	14	1150	5
CV201210-330K	33	± 10	30	0.4	13	1250	5

\*Test Frequency for L (inductance) of CV201210-47NK is 10 MHz.

### Packaging Specifications

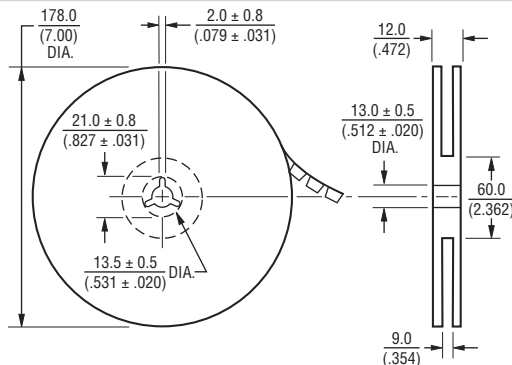

### General Specifications

Temperature Rise .....30 °C max. at rated current  
 Operating Temperature .....-55 °C to +125 °C  
 Storage Temperature .....-55 °C to +125 °C  
 Reflow Soldering ...230 °C, 50 sec. max.  
 Resistance to Soldering Heat .....260 °C, 10 seconds

### Materials

Base Material .....Ferrite  
 Terminal .....Ag/Ni/Sn  
 Packaging:  
 0.85 mm product height .....4,000 pcs. per reel  
 1.25 mm product height .....2,000 pcs. per reel

### Product Dimensions

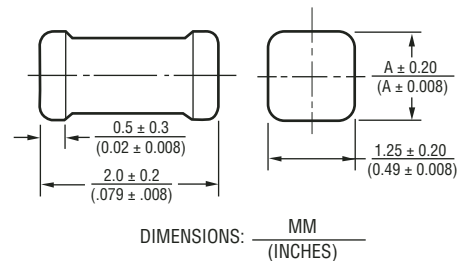

Model	Dimension A
CV201210-47NK through CV201210-R39K	0.85 (0.033)
CV201210-R47K through CV201210-R82K	1.25 (0.050)
CV201210-1R0K through CV201210-2R2K	0.85 (0.033)
CV201210-2R7K through CV201210-330K	1.25 (0.050)

### Recommended Layout

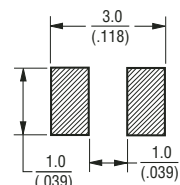

\*RoHS Directive 2002/95/EC Jan 27 2003 including Annex Specifications are subject to change without notice. Customers should verify actual device performance in their specific applications.

# CV201210 Series - Ferrite Multi-Layer Chip Inductors

**BOURNS®**

## Electrical Specifications

**Q Characteristics**

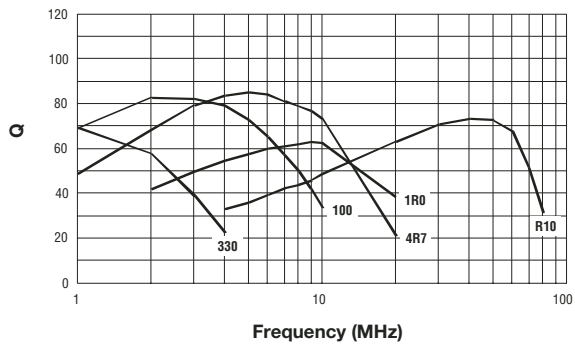

**DC Bias Characteristics**

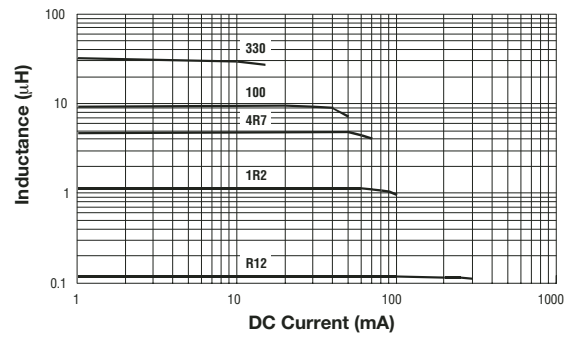

**Inductance Characteristics**

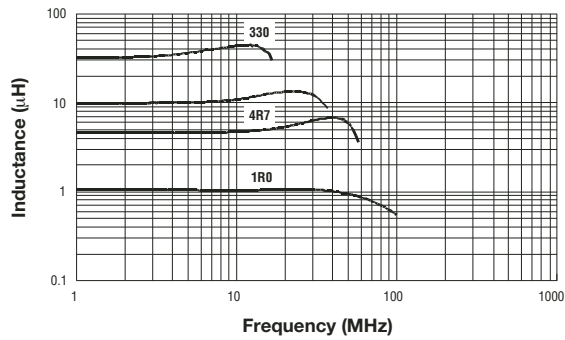

**Impedance Characteristics**

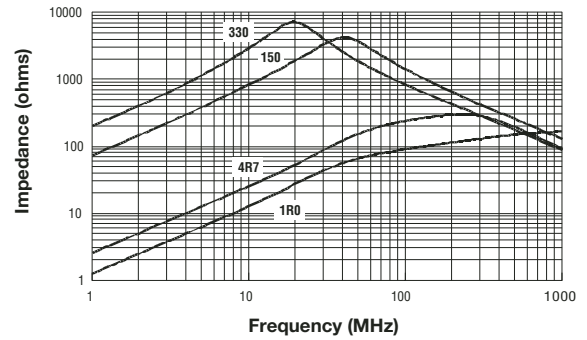

\*RoHS COMPLIANT

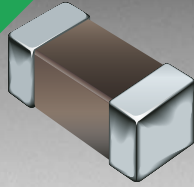

**BOURNS®**

### Features

- 1206 size
- Magnetic shielding
- High Q characteristics
- Nickel barrier
- Lead free

### Applications

- Prevention of electromagnetic interference to signals on the secondary side of electronic equipment

## CS321613 Series - Ferrite Multi-Layer Chip Inductors

### Electrical Specifications

Bourns Part No.	Inductance		Q	Test Freq.	SRF MHz		DCR	I rms
	μH	Tol. %			L, Q MHz	min.		
CS321613-47NK	0.047	±10	60	50	320	400	150	300
CS321613-68NK	0.068	±10	60	50	280	350	150	300
CS321613-R10K	0.10	±10	50	25	235	300	200	250
CS321613-R12K	0.12	±10	50	25	220	280	200	250
CS321613-R15K	0.15	±10	50	25	200	250	200	250
CS321613-R18K	0.18	±10	50	25	185	230	200	250
CS321613-R22K	0.22	±10	50	25	170	220	250	250
CS321613-R27K	0.27	±10	50	25	150	200	250	250
CS321613-R33K	0.33	±10	50	25	145	180	300	250
CS321613-R39K	0.39	±10	50	25	135	170	300	200
CS321613-R47K	0.47	±10	50	25	125	160	300	200
CS321613-R56K	0.56	±10	50	25	115	150	350	150
CS321613-R68K	0.68	±10	50	25	105	135	350	150
CS321613-R82K	0.82	±10	50	25	100	125	400	150
CS321613-1R0K	1.0	±10	80	10	75	105	250	100
CS321613-1R2K	1.2	±10	80	10	65	95	300	100
CS321613-1R5K	1.5	±10	80	10	60	85	300	50
CS321613-1R8K	1.8	±10	80	10	55	75	500	50
CS321613-2R2K	2.2	±10	80	10	50	70	600	50
CS321613-2R7K	2.7	±10	80	10	45	65	600	50
CS321613-3R3K	3.3	±10	85	10	40	55	700	50
CS321613-3R9K	3.9	±10	85	10	38	50	800	50
CS321613-4R7K	4.7	±10	85	10	35	48	800	50
CS321613-5R6K	5.6	±10	65	4	32	45	600	25
CS321613-6R8K	6.8	±10	65	4	29	40	600	25
CS321613-8R2K	8.2	±10	65	4	26	36	600	25
CS321613-100K	10.0	±10	65	2	24	33	700	25
CS321613-120K	12.0	±10	65	2	22	30	900	25
CS321613-150K	15.0	±10	45	1	19	27	1100	25
CS321613-180K	18.0	±10	45	1	18	25	1400	25
CS321613-220K	22.0	±10	45	1	16	22	1400	25
CS321613-270K	27.0	±10	45	1	14	20	1500	25
CS321613-330K	33.0	±10	45	0.4	13	18	1500	25

### General Specifications

Temperature Rise .....20 °C max. at rated current  
 Operating Temperature .....-55 °C to +125 °C  
 Storage Temperature .....-55 °C to +125 °C  
 Reflow Soldering ...230 °C, 50 sec. max.  
 Resistance to Soldering Heat .....260 °C, 10 seconds

### Materials

Base Material .....Ferrite  
 Terminal.....Ag/Ni/Sn  
 Packaging.....3,000 pcs. per reel

### Product Dimensions

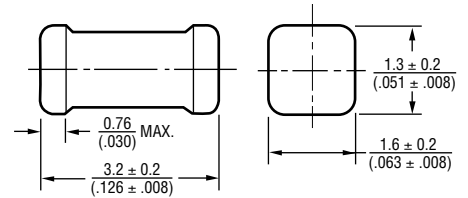

DIMENSIONS:  $\frac{\text{MM}}{\text{(INCHES)}}$

### Recommended Layout

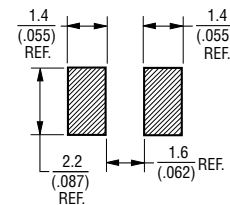

### Packaging Specifications

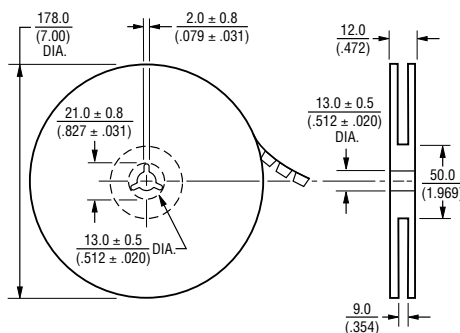

\*RoHS Directive 2002/95/EC Jan 27 2003 including Annex  
 Specifications are subject to change without notice.  
 Customers should verify actual device performance in their specific applications.



# CS321613 Series - Ferrite Multi-Layer Chip Inductors **BOURNS®**

## Electrical Specifications

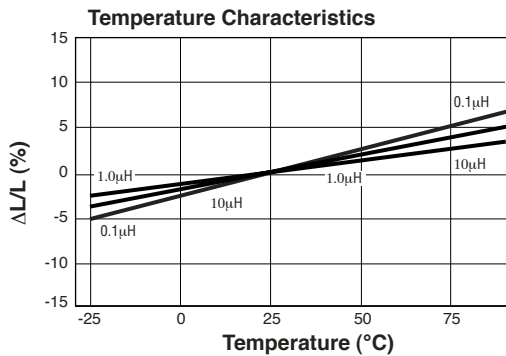
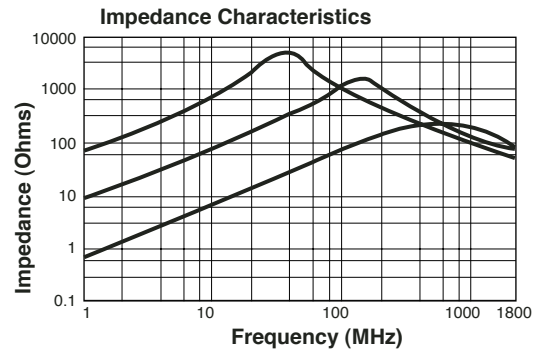
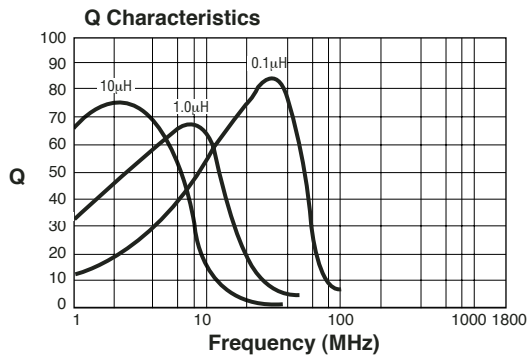
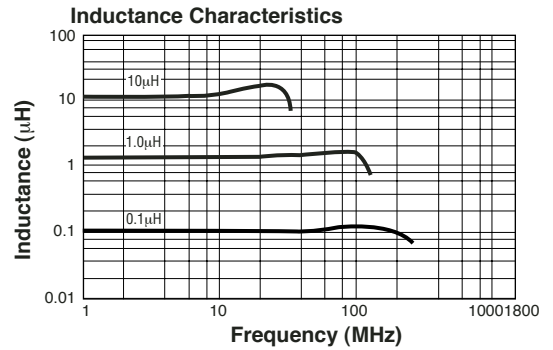
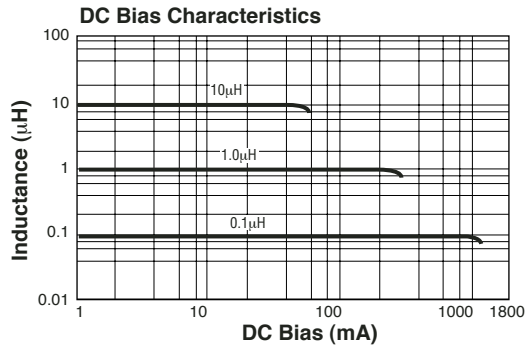

\*RoHS COMPLIANT

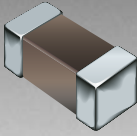

**BOURNS®**

**Features**

- 0603 size
- Magnetic shielding
- High Q characteristics
- Nickel barrier
- Lead free

**Applications**

- Prevention of electromagnetic interference to signals on the secondary side of electronic equipment

**CS160808 Series - Ferrite Multi-Layer Chip Inductors**

**Electrical Specifications**

Bourns Part No.	Inductance		Q	Test Freq.	SRF MHz		DCR	I rms
	μH	Tol. %			L, Q MHz	min.		
CS160808-47NK	0.047	±10	45	50	260	320	150	200
CS160808-68NK	0.068	±10	45	50	250	290	200	200
CS160808-82NK	0.082	±10	45	50	245	280	250	200
CS160808-R10K	0.10	±10	30	25	240	270	250	200
CS160808-R12K	0.12	±10	30	25	205	260	300	200
CS160808-R15K	0.15	±10	30	25	180	250	350	200
CS160808-R18K	0.18	±10	30	25	165	220	400	200
CS160808-R22K	0.22	±10	30	25	150	200	400	200
CS160808-R27K	0.27	±10	30	25	136	190	500	200
CS160808-R33K	0.33	±10	30	25	125	180	550	150
CS160808-R39K	0.39	±10	30	25	110	170	600	150
CS160808-R47K	0.47	±10	30	25	105	160	700	150
CS160808-R56K	0.56	±10	30	25	95	150	900	150
CS160808-R68K	0.68	±10	30	25	80	140	900	150
CS160808-R82K	0.82	±10	30	25	75	130	1400	100
CS160808-1R0K	1.0	±10	50	10	70	95	500	100
CS160808-1R2K	1.2	±10	50	10	60	80	600	100
CS160808-1R5K	1.5	±10	50	10	55	70	650	50
CS160808-1R8K	1.8	±10	50	10	50	70	750	50
CS160808-2R2K	2.2	±10	50	10	45	60	900	50
CS160808-2R7K	2.7	±10	50	10	40	55	1000	50

**General Specifications**

Temperature Rise .....20 °C max. at rated current  
 Operating Temperature .....-55 °C to +125 °C  
 Storage Temperature .....-55 °C to +125 °C  
 Reflow Soldering ...230 °C, 50 sec. max.  
 Resistance to Soldering Heat .....260 °C, 10 seconds

**Materials**

Base Material .....Ferrite  
 Terminal.....Ag/Ni/Sn  
 Packaging.....4,000 pcs. per reel

**Product Dimensions**

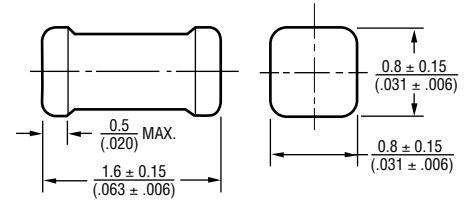

DIMENSIONS:  $\frac{\text{MM}}{\text{(INCHES)}}$

**Recommended Layout**

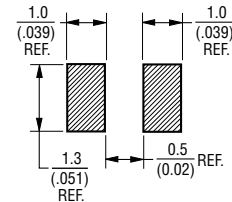

**Packaging Specifications**

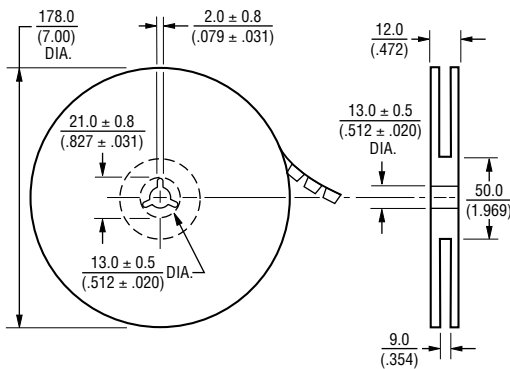

\*RoHS Directive 2002/95/EC Jan 27 2003 including Annex Specifications are subject to change without notice. Customers should verify actual device performance in their specific applications.

# CS160808 Series - Ferrite Multi-Layer Chip Inductors **BOURNS®**

## Electrical Specifications

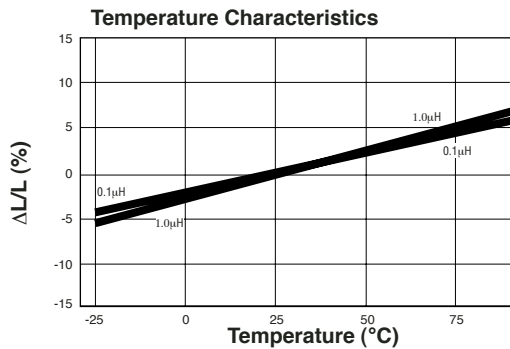
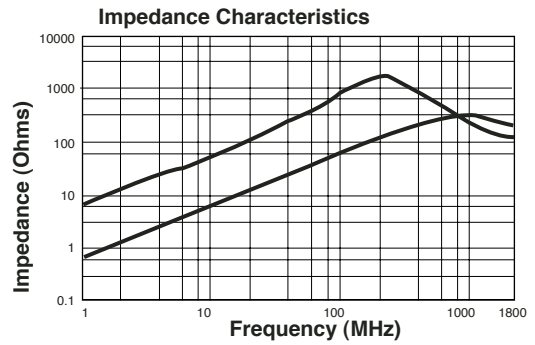
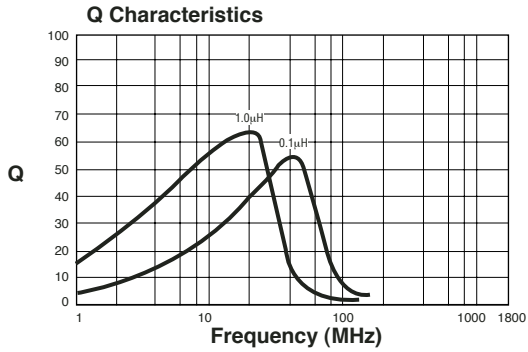
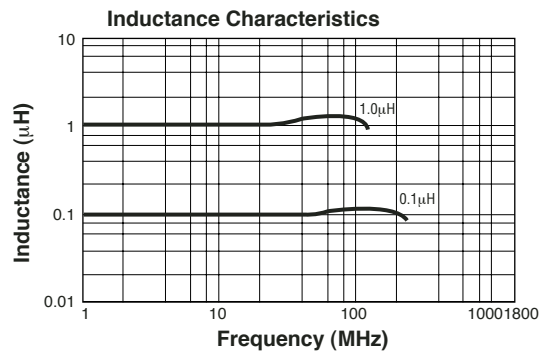
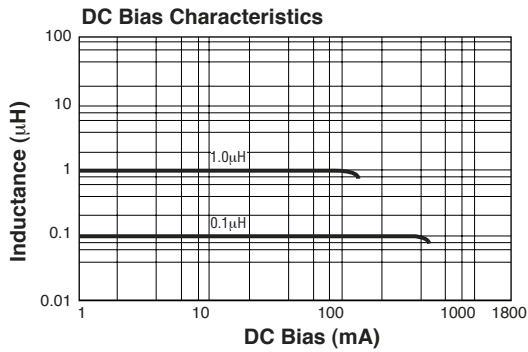

REV. 05/05

Specifications are subject to change without notice.  
Customers should verify actual device performance in their specific applications.

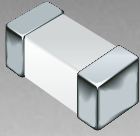

**BOURNS®**

## Features

- 0603 size
- Available in E12 Series
- High frequency
- Nickel barrier
- Lead free

## Applications

- Mobil phones
- Cellular phones
- CTV, VCR, HIC, FDD
- Automotive electronics

# CI160808 Series - Multi-Layer Chip Inductors

## Electrical Specifications

Bourns Part No.	Inductance		Q	Test Freq.	SRF MHz		DCR	I rms
	nH	Tol. %	min.	L, Q MHz	min.	typ.	ohm max.	mA max.
CI160808-1N0D	1.0	±0.3 nH	8	100	4000	13000	0.10	300
CI160808-1N2D	1.2	±0.3 nH	8	100	4000	13000	0.10	300
CI160808-1N5D	1.5	±0.3 nH	8	100	4000	10000	0.10	300
CI160808-1N8D	1.8	±0.3 nH	8	100	3800	10000	0.12	300
CI160808-2N2D	2.2	±0.3 nH	8	100	3600	10000	0.16	300
CI160808-2N7D	2.7	±0.3 nH	8	100	3400	8000	0.20	300
CI160808-3N3D	3.3	±0.3 nH	10	100	3200	6000	0.22	300
CI160808-3N9D	3.9	±0.3 nH	10	100	3000	6000	0.25	300
CI160808-4N7D	4.7	±0.3 nH	10	100	2800	5000	0.28	300
CI160808-5N6D	5.6	±0.3 nH	10	100	2700	5000	0.29	300
CI160808-6N8J	6.8	±5	10	100	2600	4000	0.30	300
CI160808-8N2J	8.2	±5	10	100	2200	4000	0.33	300
CI160808-10NJ	10	±5	10	100	1800	3000	0.35	300
CI160808-12NJ	12	±5	10	100	1650	2700	0.40	300
CI160808-15NJ	15	±5	10	100	1350	2400	0.45	300
CI160808-18NJ	18	±5	10	100	1350	2050	0.50	300
CI160808-22NJ	22	±5	10	100	1100	1850	0.55	300
CI160808-27NJ	27	±5	10	100	1100	1750	0.60	300
CI160808-33NJ	33	±5	10	100	1000	1500	0.65	300
CI160808-39NJ	39	±5	10	100	900	1350	0.70	300
CI160808-47NJ	47	±5	10	100	800	1200	0.90	300
CI160808-56NJ	56	±5	10	100	750	1150	1.00	300
CI160808-68NJ	68	±5	10	100	700	1000	1.20	300
CI160808-82NJ	82	±5	10	100	600	900	1.50	300
CI160808-R10J	100	±5	10	100	500	850	1.70	300
CI160808-R12J	120	±5	8	50	500	850	2.00	250
CI160808-R15J	150	±5	8	50	500	680	2.40	200
CI160808-R18J	180	±5	8	50	400	500	2.70	200
CI160808-R22J	220	±5	8	50	350	500	2.80	200
CI160808-R27J	270	±5	8	50	300	450	3.10	200

## General Specifications

### Temperature Rise

.....20 °C max. at rated current  
 Operating Temperature...-55 °C to +125 °C  
 Storage Temperature...-55 °C to +125 °C  
 Reflow Soldering ...230 °C, 50 sec. max.  
 Resistance to Soldering Heat  
 .....260 °C, 10 seconds

## Materials

Base Material .....Ceramic  
 Terminal.....Ag/Ni/Sn  
 Packaging.....4,000 pcs. per reel

## Product Dimensions

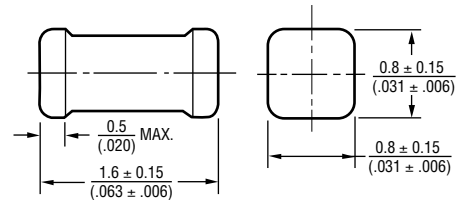

DIMENSIONS:  $\frac{\text{MM}}{\text{(INCHES)}}$

## Recommended Layout

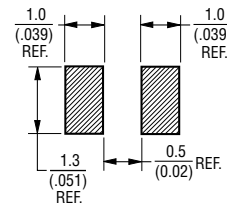

## Packaging Specifications

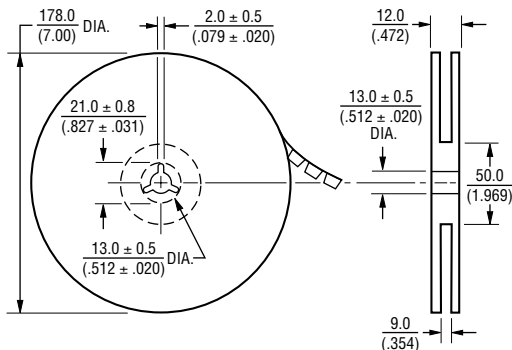

\*RoHS Directive 2002/95/EC Jan 27 2003 including Annex  
 Specifications are subject to change without notice.  
 Customers should verify actual device performance in their specific applications.

# CI160808 Series - Multi-Layer Chip Inductors

## Electrical Specifications

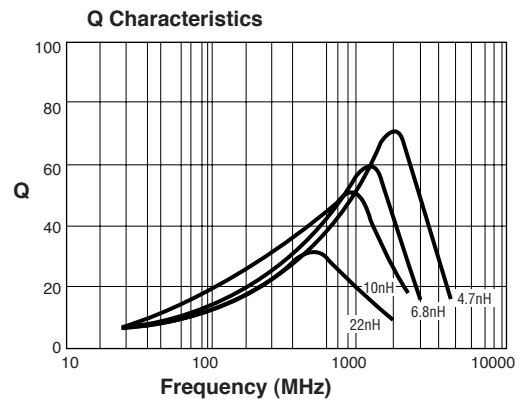
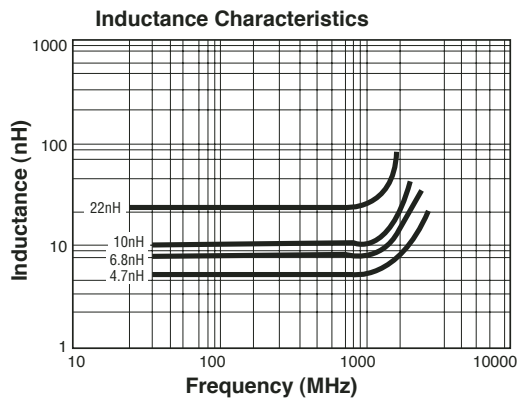

\*RoHS COMPLIANT

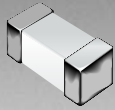

**BOURNS®**

**Features**

- 0402 size
- Available in E12 Series
- High frequency
- Nickel barrier
- Lead free

**Applications**

- Mobil phones
- Cellular phones
- CTV, VCR, HIC, FDD
- Automotive electronics

**CI100505 Series - Multi-Layer Chip Inductors**

**Electrical Specifications**

Bourns Part No.	Inductance		Q min. MHz			SRF MHz		DCR	I rms
	nH	Tol. %	100	800	1600	min.	typ.	ohm max.	mA max.
CI100505-1N0D	1.0	±0.3 nH	8	20	26	6000	13000	0.10	300
CI100505-1N2D	1.2	±0.3 nH	8	20	26	6000	10000	0.10	300
CI100505-1N5D	1.5	±0.3 nH	8	20	30	6000	10000	0.10	300
CI100505-1N8D	1.8	±0.3 nH	8	22	35	6000	9500	0.12	300
CI100505-2N2D	2.2	±0.3 nH	8	22	35	6000	9000	0.16	300
CI100505-2N7D	2.7	±0.3 nH	8	22	35	6000	9000	0.20	300
CI100505-3N3D	3.3	±0.3 nH	8	22	35	6000	8000	0.22	300
CI100505-3N9D	3.9	±0.3 nH	8	22	30	4000	6500	0.25	300
CI100505-4N7D	4.7	±0.3 nH	8	22	30	4000	5000	0.28	300
CI100505-5N6D	5.6	±0.3 nH	8	22	28	4000	5000	0.29	300
CI100505-6N8J	6.8	±5	8	22	28	3900	4400	0.35	300
CI100505-8N2J	8.2	±5	8	20	28	3600	4000	0.40	250
CI100505-10NJ	10	±5	8	20	24	3200	3500	0.45	250
CI100505-12NJ	12	±5	8	20	24	2700	3500	0.50	200
CI100505-15NJ	15	±5	8	20	20	2300	3000	0.55	200
CI100505-18NJ	18	±5	8	20	15	2100	2600	0.65	200
CI100505-22NJ	22	±5	8	20	13	1900	2200	0.80	200
CI100505-27NJ	27	±5	8	17	—	1600	1900	0.90	200
CI100505-33NJ	33	±5	8	16	—	1300	1700	1.10	200
CI100505-39NJ	39	±5	8	16	—	1200	1600	1.20	100
CI100505-47NJ	47	±5	8	10	—	1000	1300	1.30	100
CI100505-56NJ	56	±5	8	—	—	750	900	1.40	100
CI100505-68NJ	68	±5	8	—	—	700	800	1.40	100
CI100505-82NJ	82	±5	8	—	—	600	700	1.60	100
CI100505-R10J	100	±5	8	—	—	550	650	2.00	100

**General Specifications**

Temperature Rise .....20 °C max. at rated current  
 Operating Temperature ..-55 °C to +125 °C  
 Storage Temperature...-55 °C to +125 °C  
 Reflow Soldering ...230 °C, 50 sec. max.  
 Resistance to Soldering Heat .....260 °C, 10 seconds

**Materials**

Base Material .....Ceramic  
 Terminal.....Ag/Ni/Sn  
 Packaging.....10,000 pcs. per reel

**Product Dimensions**

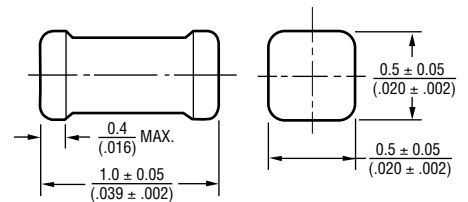

DIMENSIONS: MM  
(INCHES)

**Recommended Layout**

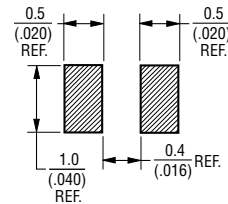

**Packaging Specifications**

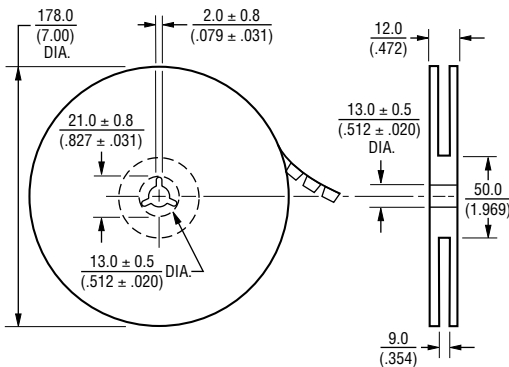

\*RoHS Directive 2002/95/EC Jan 27 2003 including Annex  
 Specifications are subject to change without notice.  
 Customers should verify actual device performance in their specific applications.

# CI100505 Series - Multi-Layer Chip Inductors

**BOURNS®**

## Electrical Specifications

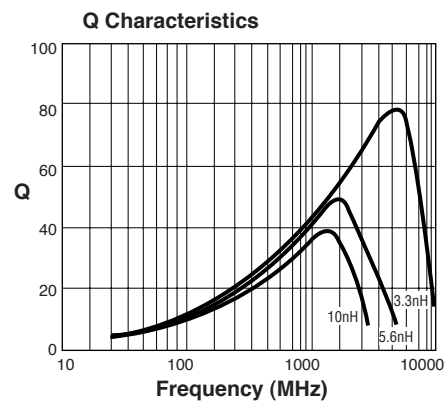
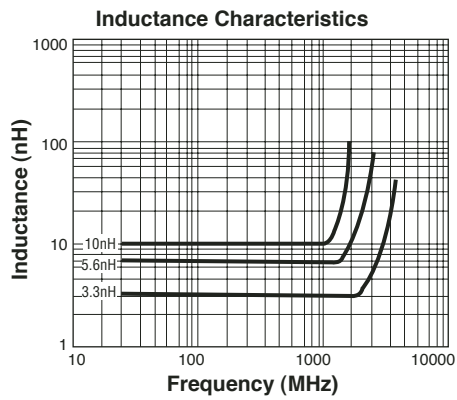

REV. 05/05

Specifications are subject to change without notice.  
Customers should verify actual device performance in their specific applications.

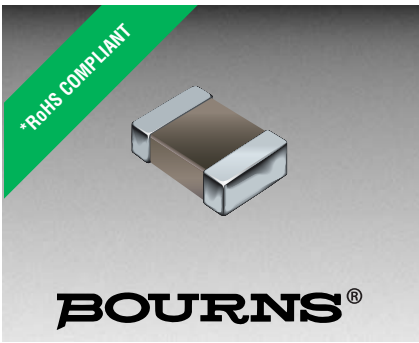

### Features

- 1008 size
- Magnetic shielding
- High Q characteristics
- High current
- Lead free



The CF252016 Series is currently available, although not recommended for new designs. Model CM252016 is preferred.

### Applications

- Prevention of electromagnetic interference to signals on the secondary side of electronic equipment

## CF252016 Series - Ferrite Multi-Layer High Current Chip Inductors

### Electrical Specifications

Bourns Part No.	Inductance		Q	Test Freq.	SRF MHz	DCR	I <sub>rms</sub>
	μH	Tol. %	min.	L <sub>Q</sub> MHz	min.	Ω max.	mA max.
CF252016-R10K	0.10	±10	30	25.2	680	0.21	570
CF252016-R12K	0.12	±10	30	25.2	650	0.22	550
CF252016-R15K	0.15	±10	30	25.2	530	0.25	500
CF252016-R18K	0.18	±10	30	25.2	520	0.29	460
CF252016-R22K	0.22	±10	30	25.2	390	0.30	430
CF252016-R27K	0.27	±10	30	25.2	330	0.33	420
CF252016-R33K	0.33	±10	30	25.2	310	0.39	400
CF252016-R39K	0.39	±10	30	25.2	290	0.40	375
CF252016-R47K	0.47	±10	30	25.2	260	0.44	350
CF252016-R56K	0.56	±10	30	25.2	230	0.49	330
CF252016-R68K	0.68	±10	30	25.2	220	0.52	320
CF252016-R82K	0.82	±10	30	25.2	180	0.61	290
CF252016-1R0K	1.0	±10	30	7.96	150	0.75	250
CF252016-1R2K	1.2	±10	30	7.96	140	0.87	240
CF252016-1R5K	1.5	±10	30	7.96	130	1.00	230
CF252016-1R8K	1.8	±10	30	7.96	120	1.10	220
CF252016-2R2K	2.2	±10	30	7.96	105	1.30	210
CF252016-2R7K	2.7	±10	30	7.96	90	1.40	200
CF252016-3R3K	3.3	±10	30	7.96	80	1.60	190
CF252016-3R9K	3.9	±10	30	7.96	75	1.70	185
CF252016-4R7K	4.7	±10	30	7.96	70	1.90	180
CF252016-5R6K	5.6	±10	30	7.96	60	2.20	170
CF252016-6R8K	6.8	±10	30	7.96	55	2.40	165
CF252016-8R2K	8.2	±10	30	7.96	50	2.60	160
CF252016-100K	10.0	±10	25	2.52	30	2.20	155
CF252016-120K	12.0	±10	25	2.52	27	2.50	150
CF252016-150K	15.0	±10	25	2.52	23	2.80	140
CF252016-180K	18.0	±10	25	2.52	22	3.20	130
CF252016-220K	22.0	±10	25	2.52	21	3.60	125
CF252016-270K	27.0	±10	25	2.52	19	4.30	115
CF252016-330K	33.0	±10	25	2.52	17	4.70	110

### Packaging Specifications

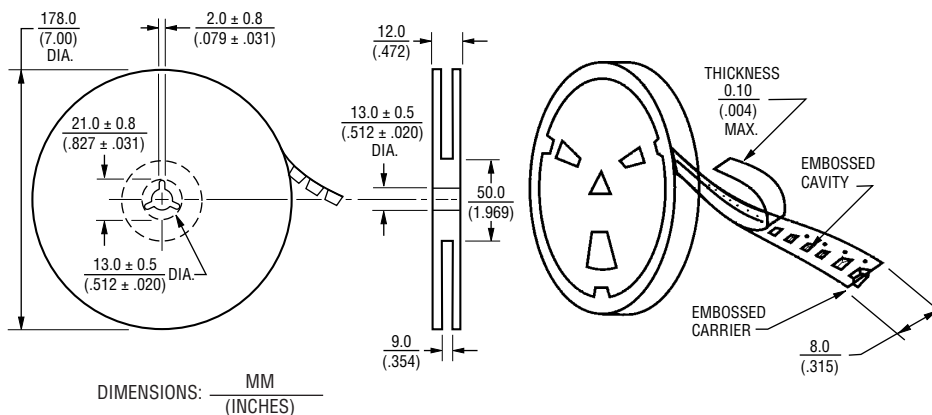

### General Specifications

Temperature Rise .....40 °C max. at rated current  
 Operating Temperature .....-55 °C to +125 °C  
 Storage Temperature...-55 °C to +125 °C  
 Reflow Soldering ...230 °C, 50 sec. max.  
 Resistance to Soldering Heat .....260 °C, 5 seconds

### Materials

Base Material .....Ferrite  
 Terminal .....Pd/Pt/Ag/Ni/Sn  
 Packaging.....2,000 pcs. per reel

### Product Dimensions

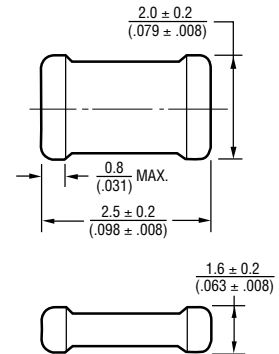

### Recommended Layout

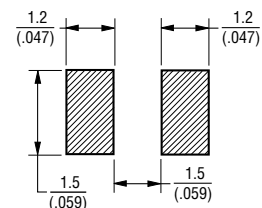

REV. 11/09

\*RoHS Directive 2002/95/EC Jan 27 2003 including Annex Specifications are subject to change without notice. Customers should verify actual device performance in their specific applications.



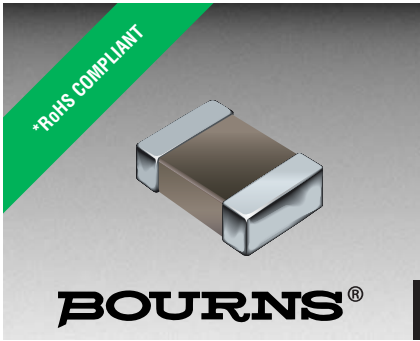

### Features

- 1210 size
- Magnetic shielding
- High Q characteristics
- High current
- Lead free



The CF322513 Series is currently available, although not recommended for new designs. Model CM322522 is preferred.

### Applications

- Prevention of electromagnetic interference to signals on the secondary side of electronic equipment

## CF322513 Series - Ferrite Multi-Layer High Current Chip Inductors

### Electrical Specifications

Bourns Part No.	Inductance		Q	Test Freq.	SRF MHz	DCR	I rms
	μH	Tol. %					
CF322513-R12K	0.12	±10	30	25.2	500	0.22	450
CF322513-R15K	0.15	±10	30	25.2	450	0.25	450
CF322513-R18K	0.18	±10	30	25.2	400	0.28	450
CF322513-R22K	0.22	±10	30	25.2	350	0.32	450
CF322513-R27K	0.27	±10	30	25.2	320	0.36	450
CF322513-R33K	0.33	±10	30	25.2	300	0.40	450
CF322513-R39K	0.39	±10	30	25.2	250	0.45	450
CF322513-R47K	0.47	±10	30	25.2	220	0.50	450
CF322513-R56K	0.56	±10	30	25.2	180	0.55	450
CF322513-R68K	0.68	±10	30	25.2	160	0.60	450
CF322513-R82K	0.82	±10	30	25.2	140	0.65	450
CF322513-1R0K	1.0	±10	30	7.96	120	0.70	400
CF322513-1R2K	1.2	±10	30	7.96	100	0.75	390
CF322513-1R5K	1.5	±10	30	7.96	85	0.85	370
CF322513-1R8K	1.8	±10	30	7.96	80	0.90	350
CF322513-2R2K	2.2	±10	30	7.96	75	1.00	320
CF322513-2R7K	2.7	±10	30	7.96	70	1.10	290
CF322513-3R3K	3.3	±10	30	7.96	60	1.20	260
CF322513-3R9K	3.9	±10	30	7.96	55	1.30	250
CF322513-4R7K	4.7	±10	30	7.96	50	1.50	220
CF322513-5R6K	5.6	±10	30	7.96	47	1.60	200
CF322513-6R8K	6.8	±10	30	7.96	43	1.80	180
CF322513-8R2K	8.2	±10	30	7.96	40	2.00	170
CF322513-100K	10.0	±10	30	2.52	36	2.10	150
CF322513-120K	12.0	±10	30	2.52	33	2.50	140
CF322513-150K	15.0	±10	30	2.52	30	2.80	130
CF322513-180K	18.0	±10	30	2.52	27	3.30	120
CF322513-220K	22.0	±10	30	2.52	25	3.70	110
CF322513-270K	27.0	±10	30	2.52	20	5.00	80
CF322513-330K	33.0	±10	30	2.52	17	5.60	70

### General Specifications

Temperature Rise .....40 °C max. at rated current  
 Operating Temperature .....-55 °C to +125 °C  
 Storage Temperature...-55 °C to +125 °C  
 Reflow Soldering ...230 °C, 50 sec. max.  
 Resistance to Soldering Heat .....260 °C, 5 seconds

### Materials

Base Material .....Ferrite  
 Terminal .....Pd/Pt/Ag/Ni/Sn  
 Packaging.....2,500 pcs. per reel

### Product Dimensions

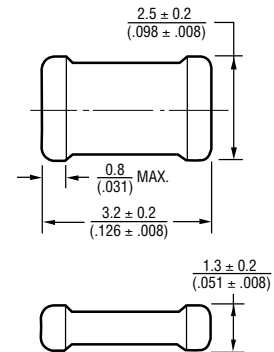

### Recommended Layout

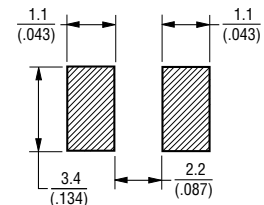

### Packaging Specifications

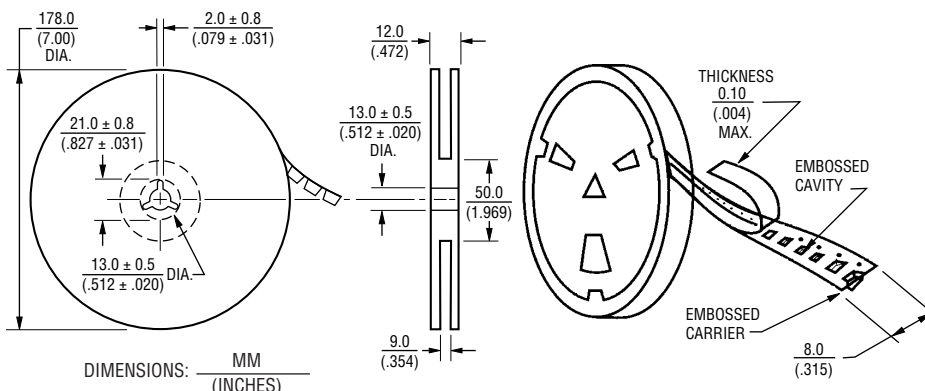

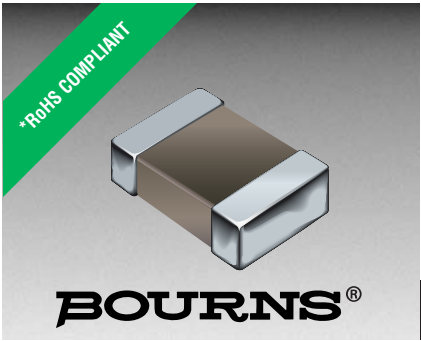

## Features

- 1812 size
- Magnetic shielding
- High Q characteristics
- High current
- Lead Free



The CF453215 Series is currently available, although not recommended for new designs. Model CM453232 is preferred.

## Applications

- Prevention of electromagnetic interference to signals on the secondary side of electronic equipment

# CF453215 Series - Ferrite Multi-Layer High Current Chip Inductors

## Electrical Specifications

Bourns Part No.	Inductance		Q	Test Freq.	SRF MHz	DCR	I rms
	μH	Tol. %	min.	L,Q MHz	min.	Ω max.	mA max.
CF453215-R10K	0.10	±10	35	25.2	300	0.18	800
CF453215-R12K	0.12	±10	35	25.2	280	0.20	770
CF453215-R15K	0.15	±10	35	25.2	250	0.22	730
CF453215-R18K	0.18	±10	35	25.2	220	0.24	700
CF453215-R22K	0.22	±10	40	25.2	200	0.25	665
CF453215-R27K	0.27	±10	40	25.2	180	0.26	635
CF453215-R33K	0.33	±10	40	25.2	165	0.28	605
CF453215-R39K	0.39	±10	40	25.2	150	0.30	575
CF453215-R47K	0.47	±10	40	25.2	145	0.32	545
CF453215-R56K	0.56	±10	40	25.2	140	0.36	520
CF453215-R68K	0.68	±10	40	25.2	135	0.40	500
CF453215-R82K	0.82	±10	40	25.2	130	0.45	475
CF453215-1R0K	1.0	±10	50	7.96	100	0.50	450
CF453215-1R2K	1.2	±10	50	7.96	80	0.55	430
CF453215-1R5K	1.5	±10	50	7.96	70	0.60	410
CF453215-1R8K	1.8	±10	50	7.96	60	0.65	390
CF453215-2R2K	2.2	±10	50	7.96	55	0.70	380
CF453215-2R7K	2.7	±10	50	7.96	50	0.75	370
CF453215-3R3K	3.3	±10	50	7.96	45	0.80	355
CF453215-3R9K	3.9	±10	50	7.96	40	0.90	330
CF453215-4R7K	4.7	±10	50	7.96	35	1.00	315
CF453215-5R6K	5.6	±10	50	7.96	33	1.10	300
CF453215-6R8K	6.8	±10	50	7.96	27	1.20	285
CF453215-8R2K	8.2	±10	50	7.96	25	1.40	270
CF453215-100K	10.0	±10	50	2.52	20	1.60	250
CF453215-120K	12.0	±10	50	2.52	18	2.00	225
CF453215-150K	15.0	±10	50	2.52	17	2.50	200
CF453215-180K	18.0	±10	50	2.52	15	2.80	190
CF453215-220K	22.0	±10	50	2.52	13	3.20	180
CF453215-270K	27.0	±10	50	2.52	12	3.60	170
CF453215-330K	33.0	±10	50	2.52	11	4.00	160

## General Specifications

Temperature Rise .....40 °C max. at rated current  
 Operating Temperature .....-55 °C to +125 °C  
 Storage Temperature...-55 °C to +125 °C  
 Reflow Soldering ...230 °C, 50 sec. max.  
 Resistance to Soldering Heat .....260 °C, 5 seconds

## Materials

Base Material .....Ferrite  
 Terminal .....Pd/Pt/Ag/Ni/Sn  
 Packaging.....1,000 pcs. per reel

## Product Dimensions

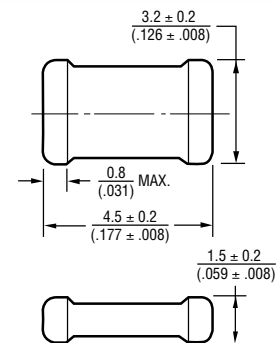

## Recommended Layout

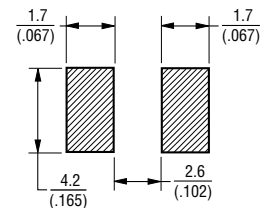

## Packaging Specifications

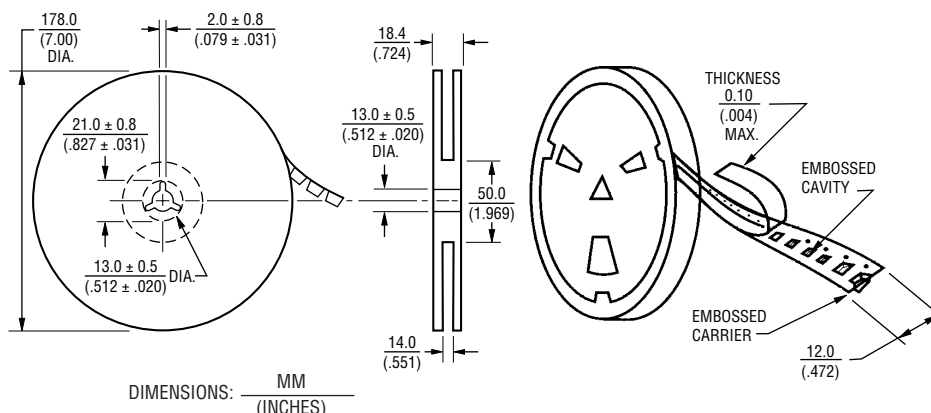

DIMENSIONS:  $\frac{\text{MM}}{\text{(INCHES)}}$

REV. 11/09

\*RoHS Directive 2002/95/EC Jan 27 2003 including Annex  
 Specifications are subject to change without notice.  
 Customers should verify actual device performance in their specific applications.



---

## II. Surface Mount Power Inductors

Product Capability Matrix.....	38
<i>SDR Non-Shielded Series Product Selection Guide</i> .....	39
<i>SRR Shielded Series Product Selection Guide</i> .....	41
<i>SRU Shielded Series Product Selection Guide</i> .....	44
<i>Soldering Profile</i> .....	44

### Product Specifications

• <i>Model SDR0302 Non-Shielded Series Power Inductors</i> .....	45
• <i>Model SDR0403 Non-Shielded Series Power Inductors</i> .....	47
• <i>Model SDR0503 Non-Shielded Series Power Inductors</i> .....	49
• <i>Model SDR0602 Non-Shielded Series Power Inductors</i> .....	51
• <i>Model SDR0603 Non-Shielded Series Power Inductors</i> .....	53
• <i>Model SDR0604 Non-Shielded Series Power Inductors</i> .....	55
• <i>Model SDR0703 Non-Shielded Series Power Inductors</i> .....	57
• <i>Model SDR0805 Non-Shielded Series Power Inductors</i> .....	59
• <i>Model SDR0906 Non-Shielded Series Power Inductors</i> .....	61
• <i>Model SDR1005 Non-Shielded Series Power Inductors</i> .....	63
• <i>Model SDR1006 Non-Shielded Series Power Inductors</i> .....	65
• <i>Model SDR1030 Non-Shielded Series Power Inductors</i> .....	67
• <i>Model SDR1045 Non-Shielded Series Power Inductors</i> .....	69
• <i>Model SDR1105 Non-Shielded Series Power Inductors</i> .....	71
• <i>Model SDR1305 Non-Shielded Series Power Inductors</i> .....	72
• <i>Model SDR1307 Non-Shielded Series Power Inductors</i> .....	74
• <i>Model SDR1806 Non-Shielded Series Power Inductors</i> .....	76
• <i>Model SDR2207 Non-Shielded Series Power Inductors</i> .....	78
• <i>Model SDR7030 Non-Shielded Series Power Inductors</i> .....	80
• <i>Model SDR7045 Non-Shielded Series Power Inductors</i> .....	82

---

• <i>Model SRR0603 Shielded Series Power Inductors</i> .....	84
• <i>Model SRR0604 Shielded Series Power Inductors</i> .....	86
• <i>Model SRR0618 Shielded Series Power Inductors</i> .....	88
• <i>Model SRR0804 Shielded Series Power Inductors</i> .....	90
• <i>Model SRR0805 Shielded Series Power Inductors</i> .....	92
• <i>Model SRR0906 Shielded Series Power Inductors</i> .....	94
• <i>Model SRR0908 Shielded Series Power Inductors</i> .....	96
• <i>Model SRR1003 Shielded Series Power Inductors</i> .....	98
• <i>Model SRR1005 Shielded Series Power Inductors</i> .....	100
• <i>Model SRR1205 Shielded Series Power Inductors</i> .....	102
• <i>Model SRR1206 Shielded Series Power Inductors</i> .....	104
• <i>Model SRR1208 Shielded Series Power Inductors</i> .....	106
• <i>Model SRR1240 Shielded Series Power Inductors</i> .....	108
• <i>Model SRR1260 Shielded Series Power Inductors</i> .....	110
• <i>Model SRR1305 Shielded Series Power Inductors</i> .....	112
• <i>Model SRR1806 Shielded Series Power Inductors</i> .....	114
• <i>Model SRR3011 Shielded Series Power Inductors</i> .....	116
• <i>Model SRR4011 Shielded Series Power Inductors</i> .....	118
• <i>Model SRR6603 Shielded Series Power Inductors</i> .....	120
• <i>Model SRR7032 Shielded Series Power Inductors</i> .....	122
• <i>Model SRR7045 Shielded Series Power Inductors</i> .....	124
• <i>Model SRU1028 Shielded Series Power Inductors</i> .....	126
• <i>Model SRU1038 Shielded Series Power Inductors</i> .....	128
• <i>Model SRU1048 Shielded Series Power Inductors</i> .....	130
• <i>Model SRU3011 Shielded Series Power Inductors</i> .....	132
• <i>Model SRU3017 Shielded Series Power Inductors</i> .....	134
• <i>Model SRU3028 Shielded Series Power Inductors</i> .....	136
• <i>Model SRU5011 Shielded Series Power Inductors</i> .....	138
• <i>Model SRU5016 Shielded Series Power Inductors</i> .....	140
• <i>Model SRU5018 Shielded Series Power Inductors</i> .....	142
• <i>Model SRU5028 Shielded Series Power Inductors</i> .....	144
• <i>Model SRU8028 Shielded Series Power Inductors</i> .....	146
• <i>Model SRU8043 Shielded Series Power Inductors</i> .....	148

# Surface Mount Power Inductors Capability Matrix

Model Series	Construction		Product Size (mm)		Product Range Minimum and Maximum Values	Current Range Min. and Max. Values
	Shielded	Non-Shielded	Length	Height		
SDR0302		•	3.0	2.5	SDR0302-1R0ML (1.0 uH) to SDR0302-122KL (1200 uH)	0.06A - 2.10A
SDR0403		•	4.5	3.2	SDR0403-1R0M (1.0uH) to SDR0403-271K (270uH)	0.20A - 3.8A
SDR0503		•	5.0	4.5	SDR0503-100M (10uH) to SDR0503-153J (15mH)	0.03A - 1.6A
SDR0602		•	5.8	2.2	SDR0602-2R7M (2.7uH) to SDR0602-561K (560uH)	0.12A - 1.5A
SDR0603		•	5.6	3.7	SDR0603-1R5M (1.5uH) to SDR0603-471K (470uH)	0.15A - 3.0A
SDR0604		•	5.6	4.5	SDR0604-1R2M (1.2uH) to SDR0604-821K (820uH)	0.20A - 7.3A
SDR0703		•	6.5	2.7	SDR0703-1R0M (1.0uH) to SDR0703-102K (1000uH)	0.08A - 2.2A
SDR0805		•	7.5	5.0	SDR0805-1R5M (1.5uH) to SDR0805-472K (4.7mH)	0.15A - 9.1A
SDR0906		•	9.5	5.5	SDR0906-2R2M (2.2uH) to SDR0906-103K (10mH)	0.10A - 6.7A
SDR1005		•	12.7	5.0	SDR1005-1R0M (1.0uH) to SDR1005-103K (10mH)	0.11A - 9.0A
SDR1006		•	10.5	6.0	SDR1006-1R5M (1.5uH) to SDR1006-472K (4700uH)	0.10A - 6.4A
SDR1030		•	10.0	3.0	SDR1030-2R7M (2.7 uH) to SDR1030-102K (1000 uH)	0.20A - 3.00A
SDR1045		•	10.0	4.5	SDR1045-2R7M (2.7 uH) to SDR1045-102K (1000 uH)	0.38A - 4.80A
SDR1105		•	11.0	4.8	SDR1105-100M (10uH) to SDR1105-201K (200uH)	0.24A - 10A
SDR1305		•	12.7	4.8	SDR1305-2R5Y (2.5 uH) to SDR1305-102K (1000 uH)	0.46A - 7.20A
SDR1307		•	13.0	7.3	SDR1307-1R5M (1.5uH) to SDR1307-102K (1000uH)	0.65A - 9.5A
SDR1806		•	18.3	6.6	SDR1806-1R0M (1.0uH) to SDR1806-102K (1000uH)	0.5A - 10A
SDR2207		•	22.0	7.0	SDR2207-R80M (0.8uH) to SDR2207-102K (1000uH)	3.0A - 35A
SDR7030		•	7.0	3.0	SDR7030-1R0M (1.0 uH) to SDR7030-102K (1000 uH)	0.15A - 3.00A
SDR7045		•	7.0	4.5	SDR7045-1R2M (1.2 uH) to SDR7045-102K (1000 uH)	0.22A - 3.80A
SRR0603	•		6.5	3.3	SRR0603-1R5M (1.5uH) to SRR0603-102K (1000uH)	0.10A - 2.2A
SRR0604	•		6.5	4.8	SRR0604-1R5M (1.5uH) to SRR0604-102K (1000uH)	0.15A - 3.9A
SRR0618	•		6.3	1.9	SRR0618-2R2M (2.2uH) to SRR0618-101M (100uH)	0.23A - 1.70A
SRR0804	•		10.5	3.8	SRR0804-5R0M (5.0uH) to SRR0804-471K (470uH)	0.28A - 2.8A
SRR0805	•		10.5	4.5	SRR0805-2R2M (2.2uH) to SRR0805-102K (1000uH)	0.24A - 4.9A
SRR0906	•		10.5	6.0	SRR0906-2R7M (2.7uH) to SRR0906-103Y (10mH)	0.07A - 3.2A
SRR0908	•		10.5	7.5	SRR0908-1R5M (10uH) to SRR0908-153Y (15mH)	0.12A - 10A
SRR1003	•		12.7	2.7	SRR1003-1R5M (1.5uH) to SRR1003-471Y (470uH)	0.45A - 8.0A
SRR1005	•		12.7	4.9	SRR1005-1R0M (1.0uH) to SRR1005-332K (3.3mH)	0.17A - 8.0A
SRR1205	•		12.7	5.0	SRR1205-2R5M (2.5uH) to SRR1205-821K (820uH)	0.57A - 10A
SRR1206	•		12.7	6.0	SRR1206-2R5M (2.5uH) to SRR1206-152K (1.5mH)	0.42A - 10A
SRR1208	•		12.7	8.0	SRR1208-2R5M (2.5uH) to SRR1208-152K (1.5mH)	0.55A - 10A
SRR1240	•		12.5	4.0	SRR1240-1R5Y (1.5 uH) to SRR1240-101M (100 uH)	1.25A - 9.20A
SRR1260	•		12.5	6.0	SRR1260-1R2Y (1.2 uH) to SRR1260-101M (100 uH)	1.70A - 9.20A
SRR1305	•		12.5	5.0	SRR1305-R90Z (0.9uH) to SRR1305-2R7Z (2.7uH)	12.0A - 20A
SRR1806	•		18.3	6.8	SRR1806-100M (10uH) to SRR1806-102M (1000uH)	0.45A - 4A
SRR3011	•		3.8	1.15	SRR3011-1R5YL (1.5 uH) to SRR3011-101YL (100 uH)	0.18A - 1.60A
SRR4011	•		4.8	1.15	SRR4011-R47YL (0.47 uH) to SRR4011-151YL (150 uH)	0.25A - 3.20A
SRR6603	•		6.6	3.0	SRR6603-1R0M (1.0uH) to SRR6603-103M (10000uH)	0.02A - 3.0A
SRR7032	•		7.0	3.2	SRR7032-3R3M (3.3 uH) to SRR7032-102M (1000 uH)	0.15A - 2.40A
SRR7045	•		7.0	4.5	SRR7045-100M (10 uH) to SRR7045-102M (1000 uH)	0.25A - 2.00A
SRU1028	•		10.0	2.8	SRR1028-1R0Y (1.0 uH) to SRR1028-151Y (150 uH)	0.70A - 7.00A
SRU1038	•		10.0	3.8	SRR1038-1R5Y (1.5 uH) to SRR1038-331Y (330 uH)	0.55A - 7.20A
SRU1048	•		10.0	4.8	SRR1048-R80Y (0.8 uH) to SRR1048-331Y (330 uH)	0.65A - 7.80A
SRU3011	•		3.5	1.1	SRU3011-1R5Y (1.5 uH) to SRU3011-100Y (10 uH)	0.40A - 1.10A
SRU3017	•		3.5	1.8	SRU3017-2R2Y (2.2 uH) to SRU3017-470Y (47 uH)	0.21A - 0.98A
SRU3028	•		3.5	2.8	SRR3028-100Y (10 uH) to SRR3028-101Y (100 uH)	0.19A - 0.72A
SRU5011	•		5.2	1.1	SRU5011-1R5Y (1.5 uH) to SRU5011-101Y (100 uH)	0.20A - 1.80A
SRU5016	•		5.2	1.6	SRU5016-1R8Y (1.8 uH) to SRU5016-101Y (100 uH)	0.30A - 1.75A
SRU5018	•		5.2	1.8	SRU5018-1R0Y (1.0 uH) to SRU5018-101Y (100 uH)	0.32A - 2.80A
SRU5028	•		5.2	2.8	SRU5028-1R2Y (1.2 uH) to SRU5028-101Y (100 uH)	0.47A - 3.50A
SRU8028	•		8.0	2.8	SRU8028-2R5Y (2.5 uH) to SRU8028-101Y (100 uH)	0.75A - 4.50A
SRU8043	•		8.0	4.3	SRU8043-2R2Y (2.2 uH) to SRU8043-101Y (100 uH)	1.00A - 5.40A

# SDR Series Non-Shielded Power Inductors Selection Guide



Current Irms and DCR, Lead Free Power Inductors										
Ind uH	Non-Shielded									
	SDR0302	SDR0403	SDR0503	SDR0603	SDR0604	SDR0805	SDR1006	SDR1307	SDR0602	SDR7030
Shape	round	round	round	round	round	round	round	round	square	square
Size mm	3.0 x 2.5	4.5 x 3.2	5.0 x 3.0	5.8 x 3.9	5.8 x 4.8	7.8 x 5.3	9.8 x 5.8	13 x 7.0	5.8x5.0x2.2	7.0 x 3.0
Term.	A / mΩ	A / mΩ	A / mΩ	A / mΩ	A / mΩ	A / mΩ	A / mΩ	A / mΩ	A / mΩ	A / mΩ
0.56										
0.8										
1	2.10 / 60.0	3.80 / 33.0								3.00 / 22.0
1.2	2.00 / 70.0				4.20 / 20.0					
1.4		3.30 / 38.0								
1.5	1.90 / 75.0			3.00 / 40.0	3.60 / 30.0	6.00 / 20.0	6.40 / 18.0	9.50 / 5.0		2.75 / 27.0
1.8	1.80 / 80.0	2.91 / 42.0								
2.2	1.65 / 90.0	2.60 / 47.0			2.80 / 60.0		5.40 / 21.0	9.00 / 6.0	1.50 / 120	2.60 / 30.0
2.5				2.35 / 50.0		5.00 / 22.0				
2.7	1.50 / 100	2.43 / 52.0			2.30 / 65.0			8.20 / 8.0		
3.3	1.40 / 110	2.15 / 58.0		2.20 / 50.0	2.00 / 70.0	4.50 / 25.0	5.00 / 24.0	7.50 / 8.7		2.20 / 38.0
3.9	1.30 / 120	1.98 / 76.0		2.10 / 55.0	1.90 / 75.0	4.40 / 28.0	4.60 / 27.0		1.40 / 130	
4.7	1.20 / 150	1.70 / 94.0		1.80 / 70.0	1.80 / 80.0	3.70 / 30.0	4.00 / 36.0	7.00 / 10.0	1.30 / 150	1.85 / 48.0
5.0				1.60 / 75.0						
5.6	1.10 / 160	1.60 / 101			1.70 / 85.0	3.50 / 35.0	3.80 / 40.0	6.50 / 15.0	1.20 / 170	
6.8	1.00 / 180	1.41 / 117		1.38 / 110	1.60 / 90.0	3.20 / 40.0	3.40 / 44.0	6.00 / 17.0	1.15 / 180	1.65 / 58.0
7.5				1.29 / 120	1.50 / 95.0	2.80 / 50.0				
8.2	0.90 / 200	1.26 / 132					3.00 / 48.0	5.80 / 19.0	1.10 / 200	
10	0.80 / 250	1.15 / 182	1.30 / 130	1.14 / 150	1.45 / 100	2.30 / 70.0	2.60 / 60.0	5.60 / 21.0	1.00 / 240	1.50 / 75.0
12	0.75 / 280	1.05 / 210	1.20 / 160	1.02 / 160	1.40 / 120	2.00 / 80.0	2.45 / 70.0	4.80 / 30.0	0.90 / 260	
15	0.65 / 400	0.92 / 235	1.05 / 190	0.93 / 180	1.30 / 140	1.80 / 90.0	2.25 / 80.0	4.50 / 34.0	0.80 / 280	1.20 / 115
18	0.58 / 460	0.84 / 338	0.95 / 210	0.82 / 250	1.25 / 150	1.60 / 100	2.15 / 90.0	4.20 / 36.0	0.75 / 300	
22	0.52 / 600	0.76 / 378	0.90 / 280	0.75 / 280	1.10 / 190	1.50 / 110	1.95 / 100	3.60 / 47.0	0.70 / 400	1.00 / 160
27	0.48 / 750	0.71 / 522	0.80 / 320	0.67 / 300	1.00 / 220	1.30 / 120	1.75 / 110	3.30 / 60.0	0.65 / 450	
33	0.42 / 850	0.64 / 540	0.70 / 380	0.61 / 450	0.88 / 250	1.20 / 140	1.50 / 120	3.10 / 65.0	0.60 / 500	0.85 / 230
36										
39	0.38 / 1120	0.59 / 587	0.65 / 420	0.56 / 460	0.80 / 320	1.10 / 160	1.35 / 140	2.90 / 75.0	0.55 / 650	
47	0.36 / 1270	0.54 / 844	0.60 / 600	0.52 / 550	0.72 / 370	1.00 / 200	1.25 / 170	2.70 / 82.0	0.50 / 680	0.70 / 340
56	0.34 / 1450	0.50 / 937	0.50 / 710	0.48 / 660	0.68 / 420	0.94 / 240	1.15 / 190	2.50 / 95.0	0.45 / 780	
68	0.30 / 1850	0.46 / 1117	0.45 / 760	0.44 / 720	0.62 / 520	0.85 / 300	1.10 / 220	2.30 / 120	0.40 / 850	0.58 / 480
82	0.28 / 2100	0.42 / 1270	0.42 / 880	0.40 / 840	0.58 / 600	0.78 / 370	1.00 / 250	2.10 / 140	0.35 / 1300	
100	0.26 / 2850	0.35 / 1900	0.40 / 1600	0.38 / 950	0.52 / 700	0.72 / 450	0.97 / 350	1.90 / 180	0.32 / 1520	0.46 / 720
120	0.22 / 3200	0.32 / 2200	0.37 / 1700	0.36 / 100	0.48 / 930	0.66 / 480	0.89 / 400	1.80 / 210	0.30 / 1650	
150	0.20 / 4600	0.26 / 3400	0.33 / 2000	0.32 / 1430	0.40 / 1100	0.58 / 680	0.78 / 470	1.60 / 250	0.26 / 2000	0.40 / 920
180	0.18 / 5000	0.24 / 3900	0.30 / 2300	0.30 / 1600	0.38 / 1380	0.51 / 770	0.72 / 630	1.50 / 280	0.23 / 2300	
220	0.17 8 5700	0.22 / 4400	0.25 / 2500	0.26 / 2000	0.35 / 1570	0.49 / 960	0.66 / 730	1.30 / 360	0.20 / 2500	0.32 / 1600
270	0.15 / 8600	0.20 / 5000	0.23 / 2900	0.24 / 2400	0.32 / 1880	0.42 / 1110	0.57 / 970	1.20 / 440	0.18 / 2850	
330	0.13/10000	0.17 / 6000	0.21 / 3300	0.20 / 3200	0.27 / 2250	0.40 / 1260	0.52 / 1150	1.10 / 520	0.16 / 3800	0.26 / 2200
390	0.12/10800	0.15 / 6400	0.19 / 3700	0.18 / 3400	0.25 / 2480	0.36 / 11770	0.48 / 1300	1.00 / 600	0.15 / 4200	
470	0.11/14300	0.13 / 7000	0.18 / 4700	0.15 / 4550	0.21 / 3300	0.34 / 1960	0.42 / 1480	0.90 / 720	0.14 / 5000	0.22 / 2800
560	0.10/16000	0.12 / 7800	0.16 / 5700		0.18 / 4000	0.30 / 2500	0.33 / 1900	0.85 / 880	0.12 / 6200	
680	0.09/18000	0.11 / 8600	0.14 / 7500		0.16 / 4650	0.28 / 2800	0.28 / 2250	0.80 / 1000		0.18 / 4350
820	0.08/22500	0.10/12000	0.12/10000		0.14 / 5200	0.23 / 4000	0.24 / 2550	0.75 / 1300		
1000	0.07/26000	0.09/14000	0.11/11500			0.21 / 4500	0.23 / 3100	0.65 / 1600		0.15 / 6200
1200	0.06/30000		0.063/12000			0.17 / 6800	0.21 / 4200			
1500			0.059/13000			0.15 / 8000	0.19 / 5000			
1800			0.055/15000			0.14 / 9200	0.17 / 6800			
2200			0.053/22000			0.13/10000	0.16 / 7600			
2700			0.050/26000			0.12/11800	0.14/11600			
3300			0.045/38000			0.10/16500	0.12/13500			
3900			0.042/40000			0.09/18000	0.11/14800			
4700			0.040/48000			0.08/21000	0.10/18000			
5000										
5600			0.038/72000							
6800			0.034/80000							
8200			0.030/92000							
10000			0.027/110Ω							
12000			0.025/148Ω							
15000			0.020/168Ω							

# SDR Series Non-Shielded Power Inductors Selection Guide



Current Irms and DCR, Lead Free Power Inductors											
Ind	Non-Shielded										
uH	SDR7045	SDR0906	SDR1030	SDR1045	SDR1105	SDR1305	SDR0703	SDR1005	SDR1806	SDR2207	
Shape	square	square	square	square	square	square	square	oval	oval	oval	oval
Size mm	7.0 x 4.5	12.5 x 6.3	10.0 x 3.0	10.0 x 4.5	11 x 4.8	12.7 x 4.8	6.5x4.5x2.7	12.7x10x5	18.3x14x6.6	22x15x7	
Term.	A / mΩ	A / mΩ	A / mΩ	A / mΩ	A / mΩ	A / mΩ	A / mΩ	A / mΩ	A / mΩ	A / mΩ	
0.56											
0.8										16.0 / 2.8	
1							2.20 / 42.0	7.50 / 7.0	10.00 / 4.0		
1.2	3.80 / 22.0						2.00 / 47.0			15.0 / 3.8	
1.4											
1.5	3.50 / 27.0							6.50 / 9.0			
1.8							1.90 / 52.0			13.0 / 4.5	
2.2	3.30 / 32.0	4.00 / 30.0					1.80 / 60.0		9.00 / 6.8		
2.5								5.50 / 12.0			
2.7		3.50 / 40.0	3.00 / 28.0	4.80 / 26.0		7.20 / 9.8	1.70 / 65.0			10.0 / 7.0	
3.3	2.80 / 36.0					6.0 / 10.5	1.65 / 75.0	5.00 / 15.0	7.60 / 9.8	9.00 / 7.8	
3.9		3.30 / 45.0					1.58 / 80.0				
4.7	2.60 / 42.0	3.00 / 50.0	2.60 / 40.0	4.20 / 33.0		5.20 / 16.5	1.50 / 100	4.50 / 19.0		8.50 / 8.8	
5.0											
5.6		2.80 / 60.0					1.40 / 105		6.40 / 15.0	7.80 / 13.4	
6.8	2.25 / 54.0	2.60 / 65.0	2.20 / 52.0	3.50 / 40.0		4.30 / 24.0	1.30 / 115	3.40 / 30.0		7.50 / 14.2	
7.5											
8.2		2.40 / 70.0					1.10 / 150			7.00 / 15.5	
10	2.00 / 70.0	2.10 / 90.0	2.00 / 64.0	3.20 / 50.0	4.00 / 45.0	3.60 / 37.0	1.00 / 170	2.90 / 50.0	5.30 / 25.0	6.50 / 17.2	
12		2.00 / 100			3.80 / 48.0		0.90 / 180			5.50 / 23.6	
15	1.60 / 86.0	1.90 / 110	1.65 / 100	2.50 / 68.0	3.50 / 52.0	3.30 / 46.0	0.75 / 240	2.50 / 60.0	4.30 / 35.0	5.00 / 28.8	
18		1.80 / 120			3.30 / 70.0		0.70 / 280			4.60 / 33.0	
22	1.40 / 125	1.60 / 130	1.38 / 145	2.20 / 88.0	3.00 / 80.0	2.90 / 62.0	0.65 / 300	2.00 / 100	3.60 / 45.0	4.00 / 39.4	
27		1.40 / 150			2.80 / 90.0		0.60 / 400			3.80 / 43.5	
33	1.22 / 150	1.25 / 180	1.10 / 220	1.90 / 110	2.60 / 100	2.50 / 85.0	0.56 / 450	1.80 / 120	3.00 / 68.0	3.40 / 58.4	
36											
39		1.15 / 190			2.40 / 140		0.50 / 550			3.20 / 65.0	
47	1.00 / 230	1.10 / 230	0.96 / 270	1.60 / 165	2.20 / 170	1.90 / 130	0.40 / 720	1.40 / 190	2.50 / 95.0	2.80 / 91.2	
56		1.05 / 260			2.00 / 200		0.39 / 800			2.60 / 96.5	
68	0.90 / 280	1.00 / 310	0.82 / 360	1.30 / 225	1.80 / 210	1.65 / 165	0.38 / 900	1.20 / 240	2.10 / 130	2.40 / 112	
82		0.95 / 330			1.60 / 300		0.33 / 1118			2.30 / 144	
100	0.75 / 430	0.90 / 390	0.70 / 540	1.10 / 300	1.50 / 320	1.40 / 255	0.27 / 1560	1.00 / 330	1.70 / 190	2.20 / 168	
120		0.85 / 430					0.26 / 1750			1.60 / 230	
150	0.62 / 580	0.75 / 560	0.60 / 700	0.85 / 500	1.20 / 500	1.20 / 380	0.25 / 2000	0.80 / 590	1.40 / 270	1.50 / 250	
180		0.70 / 640					0.19 / 2700			1.30 / 300	
220	0.50 / 930	0.60 / 850	0.46 / 1150	0.72 / 680	1.00 / 650	1.00 / 500	0.18 / 3000	0.70 / 780	1.10 / 420	1.20 / 380	
270		0.55 / 1000					0.17 / 3600			1.10 / 470	
330	0.42 / 1240	0.50 / 1270	0.38 / 1700	0.62 / 950		0.85 / 700	0.16 / 4800	0.55 / 1550	1.00 / 580	1.00 / 560	
390		0.45 / 1400					0.14 / 6200			0.90 / 680	
470	0.34 / 1850	0.40 / 1630	0.28 / 2250	0.52 / 1280		0.67 / 1150	0.13 / 7000	0.45 / 1700	0.80 / 820	0.80 / 850	
560		0.32 / 2100					0.11 / 9200			0.75 / 1000	
680	0.30 / 2400	0.28 / 2400	0.23 / 3300	0.43 / 1920		0.60 / 1400	0.10/10500	0.35 / 2600	0.70 / 1200	0.70 / 1100	
820		0.24 / 2750					0.09/12000			0.60 / 1400	
1000	0.22 / 4000	0.22 / 3500	0.20 / 4700	0.38 / 2700		0.46 / 2350	0.08/14200	0.30 / 3900	0.50 / 1800	0.55 / 1800	
1200		0.20 / 4000									
1500		0.18 / 5000						0.25 / 6300			
1800		0.17 / 5800									
2200		0.14 / 9000						0.20 / 8200			
2700		0.13 / 9000									
3300		0.12/10000						0.16/1400			
3900		0.1/13500									
4700		0.09/15000						0.15/17000			
5000											
5600		0.07/20000									
6800		0.06/23000						0.11/30000			
8200		0.05/28000						0.11/34000			
10000		0.04/33000						0.10/39000			
12000											
15000											



# SRR Series Shielded Power Inductors Selection Guide



Current Irms and DCR, Lead Free Power Inductors										
Ind	Shielded									
uH	SRR3011	SRR3018	SRR4011	SRR4018	SRR4028	SRR0510	SRR5028	SRR0618	SRR0603	SRR6022
Shape	square	square	square	square	square	square	square	square	square	square
mm	3.8 x 1.16	3.8 x 1.65	4.8 x 1.15	4.8 x 2.0	4.8 x 3.0	5.2 x 1.05	5.8 x 3.0	6.3 x 1.5	6.5 x 3.3	6.8 x 2.5
Term	A / mΩ	A / mΩ	A / mΩ	A / mΩ	A / mΩ	A / mΩ	A / mΩ	A / mΩ	A / mΩ	A / mΩ
0.47			3.20 / 30.0							
0.8										4.60 / 14.0
1										
1.2			2.50 / 48.0	2.60 / 35.0	2.56 / 20.0					
1.4										
1.5	1.30 / 55.0	1.75 / 34.0	2.10 / 56.0						2.20 / 32.0	4.00 / 18.0
1.8				2.20 / 58.0	2.20 / 25.0					
2.2			1.80 / 75.0		2.05 / 28.0	0.76 / 180		1.70 / 50.0	2.00 / 40.0	3.20 / 24.0
2.5	1.00 / 85.0	1.45 / 45.0					2.70 / 30.0			
2.7				1.95 / 60.0	1.80 / 30.0					2.60 / 32.0
3.0							2.50 / 30.0			
3.3	0.85 / 90.0		1.40 / 110	1.80 / 65.0	1.65 / 35.0	0.69 / 220		1.40 / 70.0	1.80 / 55.0	
3.5		1.38 / 65.0								
3.9				1.65 / 75.0	1.50 / 60.0					2.20 / 40.0
4.5							2.20 / 35.0			
4.7	0.75 / 125	1.20 / 85.0	1.20 / 165	1.50 / 82.0	1.30 / 70.0	0.61 / 280		1.05 / 100	1.60 / 70.0	
5.0										2.00 / 45.0
5.6				1.25 / 90.0	1.20 / 85.0		1.90 / 40.0			
6.5			1.00 / 195				1.80 / 45.0			1.70 / 54.0
6.8	0.62 / 210	0.85 / 125		1.15 / 100	1.15 / 90.0	0.52 / 380		0.95 / 150	1.20 / 100	
7.0										
7.5										15.0 / 60.0
8.2			0.92 / 215	1.10 / 135	1.05 / 100		1.60 / 55.0			
10	0.50 / 280	0.74 / 165	0.83 / 240	1.00 / 150	1.00 / 100	0.41 / 610	1.40 / 70.0	0.82 / 220	1.10 / 120	1.30 / 70.0
12				0.90 / 170	0.85 / 125		1.25 / 80.0			1.10 / 80.0
15	0.38 / 420	0.62 / 230	0.70 / 400	0.82 / 220	0.78 / 150	0.35 / 820	1.15 / 100	0.60 / 310	0.90 / 180	1.05 / 95.0
18				0.75 / 280	0.75 / 160		1.10 / 110			1.00 / 100
22	0.32 / 680	0.51 / 360	0.57 / 580	0.65 / 300	0.72 / 185	0.31 / 1100	1.00 / 120	0.47 / 460	0.70 / 270	0.95 / 120
27				0.60 / 370	0.60 / 200		0.90 / 160			0.85 / 150
33	0.27 / 860	0.42 / 545	0.47 / 860	0.50 / 420	0.58 / 230	0.23 / 1880	0.78 / 190	0.43 / 680	0.60 / 430	0.78 / 200
39				0.48 / 540	0.50 / 250		0.72 / 210			0.70 / 250
47	0.23 / 1800	0.39 / 800	0.40 / 1250	0.45 / 600	0.48 / 280	0.21 / 2340	0.65 / 250	0.36 / 1100	0.50 / 550	0.62 / 280
56				0.40 / 820	0.42 / 320		0.60 / 300			0.56 / 320
68	0.18 / 2250	0.32 / 1200	0.32 / 1800	0.38 / 860	0.36 / 400		0.56 / 350	0.30 / 1500	0.40 / 900	0.50 / 360
82			0.30 / 2200	0.32 / 1200	0.32 / 520		0.50 / 430			0.45 / 420
100	0.15 / 3600	0.25 / 2050	0.27 / 2400	0.30 / 1350	0.30 / 600		0.45 / 480	0.23 / 2300	0.30 / 1500	0.40 / 780
120					0.28 / 700					0.36 / 600
150			0.22 / 3800		0.26 / 860		0.35 / 900		0.25 / 1900	0.32 / 720
180					0.23 / 1000					0.28 / 860
220					0.20 / 1250		0.30 / 1250		0.20 / 2700	0.25 / 1100
270					0.18 / 1500					0.22 / 1300
330					0.17 / 1700		0.20 / 2000		0.18 / 4200	0.20 / 1500
390					0.16 / 2200					0.18 / 1800
470					0.155 / 2600				0.15 / 6700	0.17 / 2200
560					0.15 / 3000					0.16 / 2700
680							0.14 / 4300		0.12 / 9500	0.15 / 3500
820										0.14 / 4000
1000									0.10 / 14000	0.13 / 5000
1200										
1500										
1800										
2200										
2700										
3300										
3900										
4700										
5600										
6800										
8200										
10000										
12000										
15000										

# SRR Series Shielded Power Inductors Selection Guide



Current Irms and DCR, Lead Free Power Inductors										
Ind	Shielded									
uH	SRR0603	SRR0604	SRR7032	SRR7040	SRR7045	SRR0906	SRR0908	SRR1240	SRR1205	SRR1260
Shape	square	square	square	square	square	square	square	square	square	square
mm	6.5 x 3.3	6.5 x 4.8	7 x 3.2	7.3 x 4.0	7 x 4.5	12.5 x 6.0	12.5 x 7.5	12.5 x 4.0	12.7 x 5.5	12.5 x 6.0
Term	A / mΩ	A / mΩ	A / mΩ	A / mΩ	A / mΩ	A / mΩ	A / mΩ	A / mΩ	A / mΩ	A / mΩ
0.47										
0.8										
1										
1.2										9.20 / 8.0
1.4										
1.5	2.20 / 32.0	2.80 / 28.0					5.60 / 14.0	9.20 / 9.5		
1.8										
2.2	2.00 / 40.0	2.50 / 35.0								
2.5									5.00 / 24.0	7.80 / 11.5
2.7						3.20 / 32.0	4.80 / 19.0			
3.0										
3.3	1.80 / 55.0	2.30 / 50.0	2.40 / 27.0					6.80 / 15.0	4.50 / 30.0	7.50 / 13.0
3.5						2.90 / 36.0				
3.9								2.10 / 55.0	2.10 / 70.0	
4.5										
4.7	1.60 / 70.0	2.00 / 60.0	2.00 / 42.0			2.70 / 40.0		6.00 / 18.0		6.80 / 15.5
5.0									4.00 / 35.0	
5.6						2.50 / 46.0	3.80 / 28.0	5.40 / 20.0		
6.5										6.60 / 17.0
6.8	1.20 / 100	1.60 / 70.0	1.60 / 54.0			2.30 / 50.0		5.20 / 23.0		
7.0										
7.5							3.40 / 32.0		3.50 / 40.0	6.00 / 19.0
8.2						2.10 / 55.0				
10	1.10 / 120	1.30 / 120	1.40 / 68.0	1.84 / 49.0	2.00 / 42.0	1.80 / 80.0	3.00 / 50.0	4.00 / 32.0	3.00 / 54.0	5.50 / 20.0
12				1.71 / 58.0		1.70 / 85.0	2.50 / 50.0		2.80 / 65.0	5.20 / 23.0
15	0.90 / 180	1.10 / 130	1.10 / 95.0	1.47 / 81.0	1.60 / 62.0	1.60 / 100	2.20 / 60.0	3.50 / 47.0	2.70 / 70.0	5.00 / 27.0
18				1.31 / 91.0		1.50 / 110	2.0 / 75.0		2.60 / 82.0	4.20 / 36.0
22	0.70 / 270	0.90 / 190	0.96 / 135	1.23 / 110	1.35 / 82.0	1.40 / 130	1.90 / 80.0	3.00 / 67.5	2.40 / 95.0	4.00 / 43.0
27				1.12 / 150		1.30 / 140	1.80 / 90.0		2.00 / 120	3.60 / 45.0
33	0.60 / 430	0.70 / 250	0.76 / 200	0.96 / 170	1.15 / 115	1.20 / 150	1.70 / 100	2.30 / 97.5	1.80 / 145	3.00 / 60.0
39				0.91 / 230		1.10 / 160	1.50 / 140		1.65 / 160	2.80 / 70.0
47	0.50 / 550	0.60 / 350	0.67 / 280	0.88 / 260	0.95 / 150	1.00 / 180	1.40 / 150	2.00 / 135	1.50 / 200	2.60 / 86.0
56				0.75 / 350		0.93 / 300	1.35 / 170		1.40 / 240	2.30 / 100
68	0.40 / 900	0.50 / 500	0.60 / 380	0.69 / 380	0.77 / 210	0.85 / 350	1.25 / 180	1.50 / 200	1.30 / 280	2.10 / 1100
82				0.61 / 430		0.78 / 370	1.05 / 260		1.20 / 330	1.95 / 1450
100	0.30 / 1500	0.40 / 650	0.45 / 540	0.60 / 610	0.65 / 300	0.70 / 420	1.00 / 280	1.25 / 300	1.00 / 400	1.70 / 1800
120				0.52 / 660		0.65 / 480	0.90 / 340		0.90 / 500	1.50 / 2200
150	0.25 / 1900	0.30 / 1000	0.37 / 800	0.46 / 880	0.53 / 480	0.60 / 550	0.80 / 450		0.80 / 580	
180				0.42 / 980		0.52 / 820	0.70 / 500		0.70 / 750	
220	0.20 / 2700	0.25 / 1700	0.30 / 1300	0.36 / 1170	0.45 / 700	0.48 / 1000	0.65 / 600		0.65 / 840	
270				0.34 / 1640		0.44 / 1100	0.60 / 700		0.60 / 1000	
330	0.18 / 4200	0.20 / 2100	0.22 / 1900	0.32 / 1860	0.40 / 730	0.40 / 1300	0.55 / 800		0.54 / 1340	
390				0.29 / 2850		0.38 / 1400	0.50 / 1000		0.50 / 1500	
470	0.15 / 6700	0.18 / 3300	0.20 / 2400	0.26 / 3010	0.32 / 1100	0.35 / 1600	0.45 / 1150		0.45 / 1980	
560				0.23 / 3620		0.28 / 2700	0.38 / 1500		0.40 / 2200	
680	0.12 / 9500	0.15 / 4800	0.16 / 3750	0.22 / 4630	0.27 / 1600	0.25 / 3200	0.35 / 1700		0.35 / 2400	
820				0.20 / 5200		0.23 / 3500	0.32 / 2200		0.30 / 3000	
1000	0.10 / 14000	0.12 / 6100	0.15 / 5400	0.18 / 6000	0.25 / 2400	0.22 / 4000	0.30 / 2500			
1200						0.20 / 4400				
1500						0.18 / 5200	0.25 / 4000			
1800						0.17 / 7000				
2200						0.16 / 8500	0.20 / 5000			
2700						0.14 / 9200				
3300						0.12/11000	0.15 / 8000			
3900						0.11/16000				
4700						0.10/19000	0.12/12000			
5600						0.09/21000				
6800						0.09/24000	0.10/16500			
8200						0.08/31000	0.10/24000			
10000						0.07/38000	0.09/26000			
12000										
15000							0.08/40000			

# SRR Series Shielded Power Inductors Selection Guide



Current Irms and DCR, Lead Free Power Inductors											
Ind	Shielded										
uH	SRR1206	SRR1280	SRR1208	SRR1305	SRR6603	SRR6816	SRR0804	SRR0805	SRR1003	SRR1005	SRR1806
Shape	square	square	square	square	oval	oval	oval	oval	oval	oval	oval
mm	12.7 x 6.5	12.5 x 7.5	12.7 x 8.5	12.5 x 5.0	6.6x4.4x3.0	6.8x5.6x1.65	10x8.0x3.8	10x8.0x4.7	12.7x10x3.0	12.7x10x5.0	18x14x6.8
Term	A / mΩ	A / mΩ	A / mΩ	A / mΩ	A / mΩ	A / mΩ	A / mΩ	A / mΩ	A / mΩ	A / mΩ	A / mΩ
0.47											
0.8				20.0 / 2.5							
1											
1.2											
1.4				16.00 / 3.4							
1.5					2.80 / 45.0					3.60 / 20.0	
1.8				13.00 / 4.6					3.00 / 30.0		
2.2					1.80 / 50.0	1.90 / 55.0		2.50 / 40.0	2.76 / 45.0		
2.5	6.20 / 16.0	9.20 / 10.0	7.50 / 11.0							3.10 / 27.0	
2.7				12.00 / 5.4							
3.0									2.20 / 62.0	2.90 / 30.0	
3.3		8.80 / 12.0			1.60 / 55.0						
3.5											
3.9											
4.5		8.50 / 13.5	6.50 / 14.0								
4.7					1.40 / 60.0	1.50 / 85.0			1.90 / 80.0	2.50 / 40.0	
5.0	4.70 / 22.0						1.70 / 80.0				
5.6		8.00 / 16.0						1.95 / 65.0			
6.5			6.00 / 18.0								
6.8					1.20 / 65.0	1.05 / 125					
7.0										2.20 / 55.0	
7.5	3.80 / 25.0	6.40 / 17.5					1.40 / 100		1.44 / 100		
8.2								1.75 / 80.0			
10	3.30 / 35.0	6.00 / 19.5	5.00 / 21.0		1.00 / 75.0	0.96 / 170	1.20 / 120	1.50 / 100	1.24 / 150	2.00 / 65.0	4.00 / 33.0
12	3.00 / 38.0		4.80 / 25.0				1.10 / 150	1.40 / 120	1.10 / 190	1.80 / 80.0	
15	2.80 / 42.0	5.20 / 28.5	4.00 / 35.0		0.80 / 90.0	0.70 / 265	1.00 / 170	1.30 / 140	1.02 / 200	1.70 / 85.0	3.60 / 39.0
18	2.50 / 50.0		3.80 / 40.0				0.90 / 190	1.20 / 160	0.90 / 270	1.60 / 90.0	
22	2.30 / 62.0	4.30 / 38.5	3.50 / 43.0		0.70 / 110	0.60 / 390	0.80 / 250	1.10 / 180	0.85 / 300	1.40 / 100	3.00 / 53.0
27	2.00 / 68.0		3.00 / 48.0				0.70 / 270	1.00 / 200	0.75 / 400	1.30 / 120	
33	1.90 / 90.0	3.50 / 57.0	2.80 / 62.0		0.60 / 190	0.42 / 520	0.65 / 300	0.92 / 240	0.70 / 450	1.20 / 160	2.50 / 83.0
39	1.75 / 100		2.50 / 76.0				0.60 / 380	0.84 / 260	0.65 / 560	1.05 / 180	
47	1.60 / 130	2.90 / 80.0	2.20 / 85.0		0.50 / 230	0.38 / 770	0.55 / 460	0.75 / 280	0.60 / 650	1.00 / 190	2.00 / 110
56	1.45 / 145		2.00 / 110				0.50 / 600	0.68 / 380	0.52 / 680	0.90 / 210	
68	1.30 / 170	2.40 / 120	1.80 / 135		0.40 / 290	0.32 / 1050	0.45 / 700	0.60 / 440	0.48 / 800	0.82 / 340	1.60 / 170
82	1.20 / 185		1.60 / 150				0.40 / 800	0.54 / 550	0.42 / 1200	0.75 / 380	
100	1.10 / 220	2.10 / 150	1.50 / 170		0.30 / 480	0.24 / 1650	0.37 / 950	0.50 / 600	0.40 / 1400	0.68 / 420	1.30 / 270
120	1.00 / 260		1.40 / 190				0.35 / 1000	0.45 / 750	0.35 / 1520	0.60 / 460	
150	0.90 / 320		1.30 / 240		0.26 / 590		0.30 / 1300	0.40 / 900	0.32 / 1800	0.55 / 520	1.05 / 400
180	0.80 / 330		1.20 / 270				0.28 / 1450	0.35 / 1050	0.28 / 2200	0.50 / 700	
220	0.70 / 460		1.10 / 380		0.22 / 770		0.24 / 1900	0.30 / 1180	0.26 / 2200	0.45 / 800	1.00 / 510
270	0.65 / 520		0.95 / 400				0.22 / 2150	0.27 / 1400	0.22 / 3100	0.40 / 1100	
330	0.60 / 660		0.85 / 650		0.20 / 1400		0.19 / 2800	0.24 / 1800	0.20 / 3600	0.35 / 1200	0.80 / 790
390	0.55 / 870		0.80 / 670				0.17 / 3300	0.22 / 2100	0.18 / 4600	0.33 / 1400	
470	0.50 / 970		0.70 / 850		0.19 / 1800		0.16 / 3600	0.20 / 2250	0.16 / 5100	0.30 / 1600	0.64 / 1000
560	0.45 / 1320		0.65 / 900					0.18 / 3000		0.28 / 1800	
680	0.40 / 1500		0.60 / 1000		0.18 / 2200			0.17 / 3400		0.26 / 2300	0.54 / 1470
820	0.35 / 1700		0.55 / 1150					0.16 / 4000		0.24 / 2600	
1000	0.30 / 2300		0.50 / 1650		0.15 / 3400			0.15 / 5000		0.22 / 3200	0.45 / 2160
1200	0.25 / 2650		0.40 / 2000							0.20 / 3600	
1500	0.20 / 3500		0.36 / 2350		0.12 / 4200					0.17 / 5200	
1800										0.16 / 5700	
2200					0.10 / 8500					0.14 / 6500	
2700										0.12 / 8600	
3300					0.08/11000					0.10/10000	
3900											
4700					0.06/13900						
5600											
6800					0.04/25000						
8200											
10000					0.02/32800						
12000											
15000											

Current Irms and DCR, Lead Free Power Inductors												
Ind	Shielded											
	SRU1028	SRU1038	SRU1048	SRU3011	SRU3017	SRU3028	SRU5011	SRU5016	SRU5018	SRU5028	SRU8028	SRU8043
uH	hexagonal	hexagonal	hexagonal	hexagonal	hexagonal	hexagonal	hexagonal	hexagonal	hexagonal	hexagonal	hexagonal	hexagonal
mm	10 x 2.8	10 x 3.8	10 x 4.8	3.3 x 1.2	3.3 x 1.8	3.3 x 2.8	5 x 1.1	5 x 1.6	5 x 1.8	5 x 2.8	8 x 2.8	8 x 4.3
Term	A / mΩ	A / mΩ	A / mΩ	A / mΩ	A / mΩ	A / mΩ	A / mΩ	A / mΩ	A / mΩ	A / mΩ	A / mΩ	A / mΩ
0.8			7.80 / 3.6									
1.0	7.00 / 4.9								2.80 / 12.5			
1.2										3.50 / 16.8		
1.5	6.50 / 7.3	7.20 / 5.0	7.00 / 4.3	1.10 / 57.0			1.80 / 32.0		2.50 / 15.5			
1.8								1.75 / 24.0				
2.2	5.30 / 11.0	6.80 / 7.7	6.50 / 5.3	0.92 / 80.0	0.98 / 35.0				2.30 / 20.5	3.20 / 21.0		5.40 / 11.2
2.5							1.30 / 52.0				4.50 / 13.6	
3.0			6.20 / 7.2									
3.3	4.60 / 15.0			0.84 / 116	0.80 / 55.0		1.15 / 66.0	1.55 / 35.0		2.80 / 24.0	3.60 / 17.5	
3.5		5.50 / 11.5							2.10 / 32.0			
3.9												4.80 / 14.6
4.7	4.50 / 16.5		5.50 / 9.5	0.63 / 178	0.63 / 68.0		1.00 / 95.0	1.30 / 42.0	2.00 / 36.0	2.20 / 32.0	3.70 / 20.0	4.60 / 17.0
5.0		4.60 / 14.5										
6.2		4.00 / 16.5										
6.8	3.50 / 25.0		4.80 / 13.6	0.50 / 245	0.53 / 85.0		0.82 / 130	1.20 / 50.0	1.45 / 50.0	2.00 / 42.0	2.80 / 34.0	3.80 / 22.4
8.2	3.30 / 28.5		4.60 / 15.0									
10	2.80 / 40.0	3.80 / 25.0	4.50 / 18.5	0.35 / 340	0.47 / 120	0.72 / 160	0.70 / 170	1.00 / 84.0	1.25 / 65.0	1.80 / 63.0	2.60 / 45.0	3.50 / 30.0
15	2.00 / 69.0	2.80 / 37.0	3.20 / 29.0		0.35 / 175	0.66 / 230	0.60 / 250	0.80 / 130	0.95 / 100	1.10 / 108	2.00 / 66.0	2.70 / 46.0
22	1.60 / 104	2.20 / 55.8	2.60 / 42.0		0.30 / 250	0.60 / 270	0.50 / 380	0.65 / 195	0.68 / 160	0.95 / 162	1.60 / 106	2.20 / 72.5
33	1.25 / 139	1.80 / 86.0	2.10 / 63.0		0.25 / 430	0.47 / 450	0.38 / 550	0.54 / 300	0.66 / 220	0.80 / 203	1.30 / 147	1.70 / 100
47	1.30 / 167	1.65 / 121	1.70 / 94.0		0.21 / 540	0.32 / 815	0.32 / 800	0.46 / 390	0.54 / 330	0.70 / 285	1.20 / 177	1.50 / 120
56	1.10 / 208		1.60 / 110									
68	1.00 / 232	1.10 / 166	1.40 / 127			0.24 / 1400	0.26 / 1240	0.36 / 560	0.37 / 480	0.56 / 450	0.85 / 317	1.20 / 192
82	0.90 / 323		1.30 / 149									
100	0.85 / 365	1.30 / 220	1.20 / 160			0.19 / 2200	0.20 / 1600	0.30 / 850	0.32 / 620	0.47 / 625	0.75 / 390	1.00 / 287
120	0.65 / 428											
150	0.60 / 518	0.90 / 358	1.00 / 235									
220		0.65 / 565	0.80 / 350									
330		0.55 / 773	0.65 / 490									

## Soldering Profile

### Bourns Soldering Profile for Chip Inductors and Power Chokes

(Note: Profiles on Individual Data Sheets Supersede This Profile)

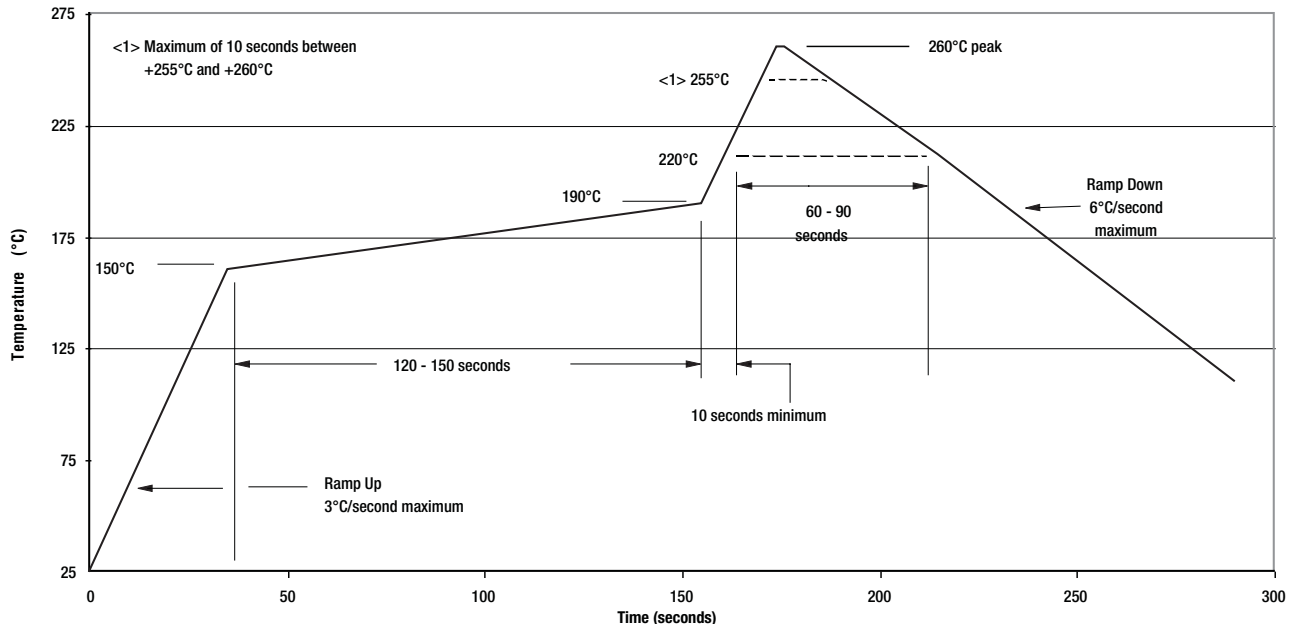

Rev. 022205

\*RoHS COMPLIANT

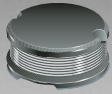

**BOURNS®**

## Features

- Available in E12 series
- Low profile of only 2.5 mm
- Low inductance values
- RoHS compliant\*

## Applications

- Input/output of DC/DC converters
- Power supplies for:
  - Portable communication equipment
  - Camcorders
  - LCD TVs
  - Car radios

# SDR0302 Series - SMD Power Inductors

### Electrical Specifications

Bourns Part No.	Inductance 1kHz		Q Ref.	Test Frequency (MHz)	SRF Min. (MHz)	RDC Max. (Ω)	I rms Max. (A)	I sat Typ. (A)
	(μH)	Tol. %						
SDR0302-1R0ML	1.0	± 20	20	7.96	125.0	0.06	2.100	2.700
SDR0302-1R2ML	1.2	± 20	22	7.96	100.0	0.07	2.000	2.500
SDR0302-1R4ML	1.4	± 20	22	7.96	95.0	0.07	1.500	2.300
SDR0302-1R5ML	1.5	± 20	23	7.96	95.0	0.07	1.900	2.300
SDR0302-1R8ML	1.8	± 20	23	7.96	85.0	0.08	1.800	2.000
SDR0302-2R2ML	2.2	± 20	22	7.96	75.0	0.09	1.650	1.850
SDR0302-2R7ML	2.7	± 20	22	7.96	72.0	0.10	1.500	1.700
SDR0302-3R3ML	3.3	± 20	23	7.96	68.0	0.11	1.400	1.600
SDR0302-3R9ML	3.9	± 20	24	7.96	50.0	0.12	1.300	1.500
SDR0302-4R7ML	4.7	± 20	18	7.96	45.0	0.15	1.200	1.350
SDR0302-5R6ML	5.6	± 20	18	7.96	42.0	0.16	1.100	1.300
SDR0302-6R8ML	6.8	± 20	18	7.96	40.0	0.18	1.000	1.200
SDR0302-8R2ML	8.2	± 20	16	7.96	35.0	0.20	0.900	1.050
SDR0302-100ML	10.0	± 20	18	2.52	34.0	0.25	0.800	0.900
SDR0302-120ML	12.0	± 20	15	2.52	33.0	0.28	0.750	0.850
SDR0302-150ML	15.0	± 20	20	2.52	32.0	0.40	0.650	0.800
SDR0302-180ML	18.0	± 20	18	2.52	28.0	0.46	0.580	0.750
SDR0302-220ML	22.0	± 20	23	2.52	22.0	0.66	0.520	0.650
SDR0302-270ML	27.0	± 20	23	2.52	20.0	0.75	0.480	0.550
SDR0302-330KL	33.0	± 10	20	2.52	18.0	0.85	0.420	0.500
SDR0302-390KL	39.0	± 10	24	2.52	18.0	1.12	0.380	0.450
SDR0302-470KL	47.0	± 10	23	2.52	17.0	1.27	0.360	0.400
SDR0302-560KL	56.0	± 10	18	2.52	16.0	1.45	0.340	0.350
SDR0302-680KL	68.0	± 10	24	2.52	14.0	1.85	0.300	0.320
SDR0302-820KL	82.0	± 10	24	2.52	12.0	2.10	0.280	0.300
SDR0302-101KL	100.0	± 10	40	0.796	10.0	2.85	0.260	0.280
SDR0302-121KL	120.0	± 10	40	0.796	10.0	3.20	0.220	0.250
SDR0302-151KL	150.0	± 10	38	0.796	9.0	4.60	0.200	0.230
SDR0302-181KL	180.0	± 10	45	0.796	8.5	5.00	0.185	0.210
SDR0302-221KL	220.0	± 10	40	0.796	8.0	5.70	0.170	0.190
SDR0302-271KL	270.0	± 10	45	0.796	7.0	8.60	0.150	0.170
SDR0302-331KL	330.0	± 10	40	0.796	6.0	10.00	0.130	0.150
SDR0302-391KL	390.0	± 10	40	0.796	5.5	10.80	0.120	0.140
SDR0302-471KL	470.0	± 10	42	0.796	5.0	14.30	0.105	0.130
SDR0302-561KL	560.0	± 10	43	0.796	4.8	16.00	0.095	0.120
SDR0302-681KL	680.0	± 10	43	0.796	4.3	18.00	0.085	0.110
SDR0302-821KL	820.0	± 10	45	0.796	4.0	22.50	0.080	0.100
SDR0302-102KL	1000.0	± 10	40	0.252	3.2	26.00	0.070	0.090
SDR0302-122KL	1200.0	± 10	40	0.252	3.0	30.00	0.060	0.080

### Typical Part Marking

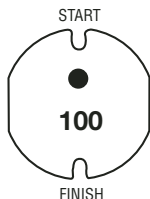

### Electrical Schematic



### General Specifications

Test Voltage ..... 1 V  
 Reflow Soldering ... 230 °C, 50 sec. max.  
 Operating Temperature  
 ..... -40 °C to +125 °C  
 (Temperature rise included)  
 Storage Temperature  
 ..... -40 °C to +125 °C  
 Resistance to Soldering Heat  
 ..... 260 °C for 5 sec.

### Materials

Core ..... Ferrite DR  
 Wire ..... Enameled copper wire 130  
 Terminal ..... Ag/Ni/Sn  
 Rated Current  
 ..... Ind. drop 10 % typ. at Isat  
 Temperature Rise ..... 40 °C max.  
 at rated I rms  
 Packaging ..... 2000 pcs. per reel

### Product Dimensions

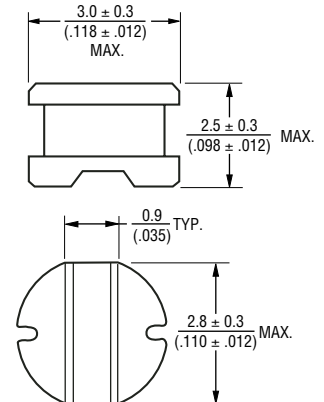

### Recommended Layout

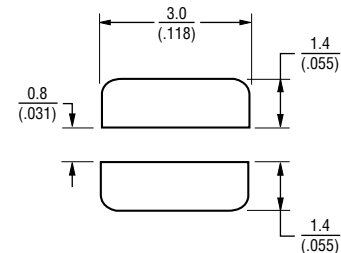

DIMENSIONS:  $\frac{\text{MM}}{\text{(INCHES)}}$

\*RoHS Directive 2002/95/EC Jan 27 2003 including Annex  
 Specifications are subject to change without notice.  
 Customers should verify actual device performance in their specific applications.

# SDR0302 Series - SMD Power Inductors

**BOURNS®**

## Packaging Specifications

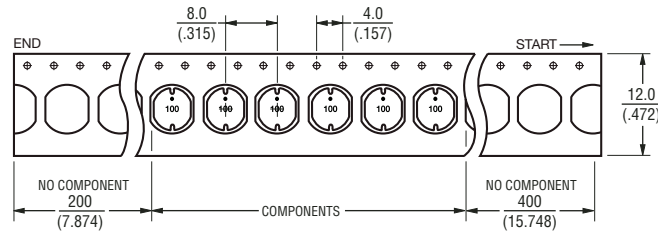
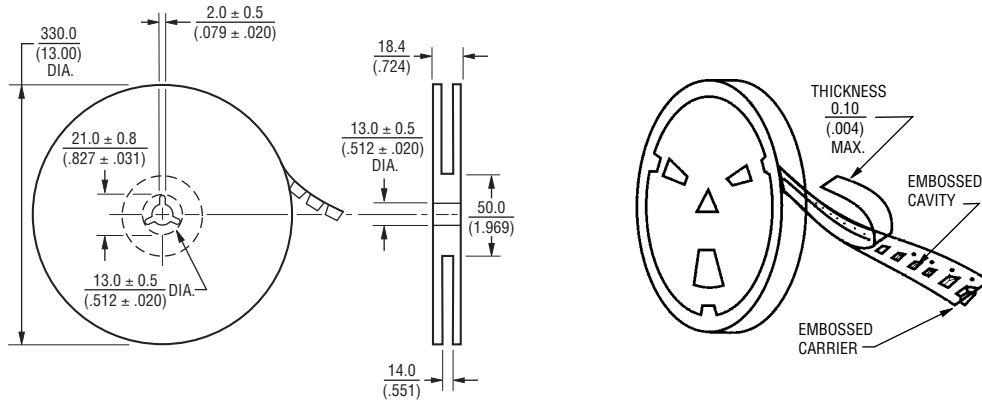

USER DIRECTION OF FEED

QTY: 2000 PCS. PER REEL

DIMENSIONS:  $\frac{\text{MM}}{\text{(INCHES)}}$

REV. 10/08

Specifications are subject to change without notice.  
Customers should verify actual device performance in their specific applications.



## Features

- Available in E12 series
- Low profile of only 3.2 mm
- Low inductance values
- RoHS compliant\*

## Applications

- Input/output of DC/DC converters
- Power supplies for:
  - Portable communication equipment
  - Camcorders
  - LCD TVs
  - Car radios

# SDR0403 Series - SMD Power Inductors

### Electrical Specifications

Bourns Part No.	Inductance 1kHz		Q Ref.	Test Frequency (MHz)	SRF Min. (MHz)	RDC Max. ( $\Omega$ )	I rms Max. (A)	I sat Typ. (A)
	( $\mu$ H)	Tol. %						
SDR0403-1R0ML	1.0	$\pm 20$	28	7.96	150	0.033	3.80	5.50
SDR0403-1R4ML	1.4	$\pm 20$	28	7.96	110	0.038	3.30	5.10
SDR0403-1R8ML	1.8	$\pm 20$	28	7.96	90	0.042	2.91	4.40
SDR0403-2R2ML	2.2	$\pm 20$	28	7.96	80	0.047	2.60	3.90
SDR0403-2R7ML	2.7	$\pm 20$	28	7.96	75	0.052	2.43	3.50
SDR0403-3R3ML	3.3	$\pm 20$	28	7.96	65	0.058	2.15	3.00
SDR0403-3R9ML	3.9	$\pm 20$	28	7.96	55	0.076	1.98	2.70
SDR0403-4R7ML	4.7	$\pm 20$	28	7.96	50	0.094	1.70	2.60
SDR0403-5R6ML	5.6	$\pm 20$	28	7.96	45	0.10	1.60	2.40
SDR0403-6R8ML	6.8	$\pm 20$	28	7.96	40	0.12	1.41	2.10
SDR0403-8R2ML	8.2	$\pm 20$	28	7.96	36	0.13	1.26	1.90
SDR0403-100ML	10	$\pm 20$	28	2.52	33	0.18	1.15	1.70
SDR0403-120ML	12	$\pm 20$	28	2.52	30	0.21	1.05	1.60
SDR0403-150ML	15	$\pm 20$	28	2.52	28	0.24	0.92	1.40
SDR0403-180ML	18	$\pm 20$	25	2.52	23	0.34	0.84	1.30
SDR0403-220ML	22	$\pm 20$	25	2.52	20	0.38	0.76	1.20
SDR0403-270KL	27	$\pm 10$	23	2.52	17	0.52	0.71	1.00
SDR0403-330KL	33	$\pm 10$	23	2.52	15	0.54	0.64	0.99
SDR0403-390KL	39	$\pm 10$	20	2.52	14	0.59	0.59	0.92
SDR0403-470KL	47	$\pm 10$	20	2.52	13	0.84	0.54	0.78
SDR0403-560KL	56	$\pm 10$	20	2.52	12	0.94	0.50	0.74
SDR0403-680KL	68	$\pm 10$	20	2.52	11	1.12	0.46	0.68
SDR0403-820KL	82	$\pm 10$	25	2.52	10	1.27	0.42	0.58
SDR0403-101KL	100	$\pm 10$	35	0.796	9	1.90	0.35	0.51
SDR0403-121KL	120	$\pm 10$	50	0.796	8	2.20	0.32	0.44
SDR0403-151KL	150	$\pm 10$	50	0.796	8	3.40	0.26	0.40
SDR0403-181KL	180	$\pm 10$	50	0.796	5	3.90	0.24	0.39
SDR0403-221KL	220	$\pm 10$	50	0.796	4	4.40	0.22	0.33
SDR0403-271KL	270	$\pm 10$	45	0.796	3	5.00	0.20	0.30
SDR0403-331KL	330	$\pm 10$	40	0.796	4	6.00	0.17	0.25
SDR0403-391KL	390	$\pm 10$	40	0.796	3.5	6.40	0.15	0.22
SDR0403-471KL	470	$\pm 10$	50	0.796	3	7.00	0.13	0.19
SDR0403-561KL	560	$\pm 10$	50	0.796	2.8	7.80	0.12	0.18
SDR0403-681KL	680	$\pm 10$	40	0.796	2.8	8.60	0.11	0.16
SDR0403-821KL	820	$\pm 10$	38	0.796	2.5	12.00	0.10	0.15
SDR0403-102KL	1000	$\pm 10$	38	0.252	2	14.00	0.09	0.13

### General Specifications

Test Voltage ..... 1 V  
 Reflow Soldering ... 230 °C, 50 sec. max.  
 Operating Temperature .. -40 °C to +125 °C  
 (Temperature rise included)  
 Storage Temperature .. -40 °C to +125 °C  
 Resistance to Soldering Heat  
 ..... 260 °C for 5 sec.

### Materials

Core ..... Ferrite DR  
 Wire ..... Enameled copper wire 130  
 Terminal ..... Ag/Ni/Sn  
 Rated Current  
 ..... Ind. drop 10 % typ. at Isat  
 Temperature Rise ..... 40 °C max.  
 at rated Irms  
 Packaging ..... 2000 pcs. per reel

### Product Dimensions

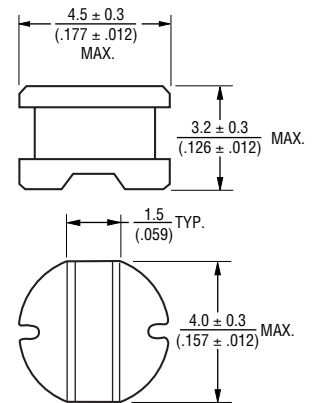

### Recommended Layout

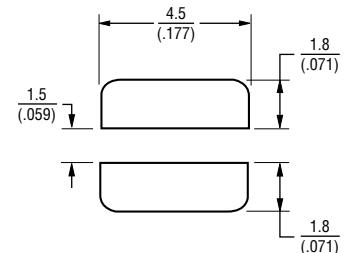

### Typical Part Marking

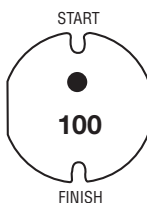

### Electrical Schematic

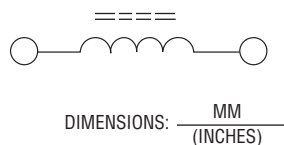

\*RoHS Directive 2002/95/EC Jan 27, 2003 including Annex  
 Specifications are subject to change without notice.  
 Customers should verify actual device performance in their specific applications.

# SDR0403 Series - SMD Power Inductors

**BOURNS®**

## Packaging Specifications

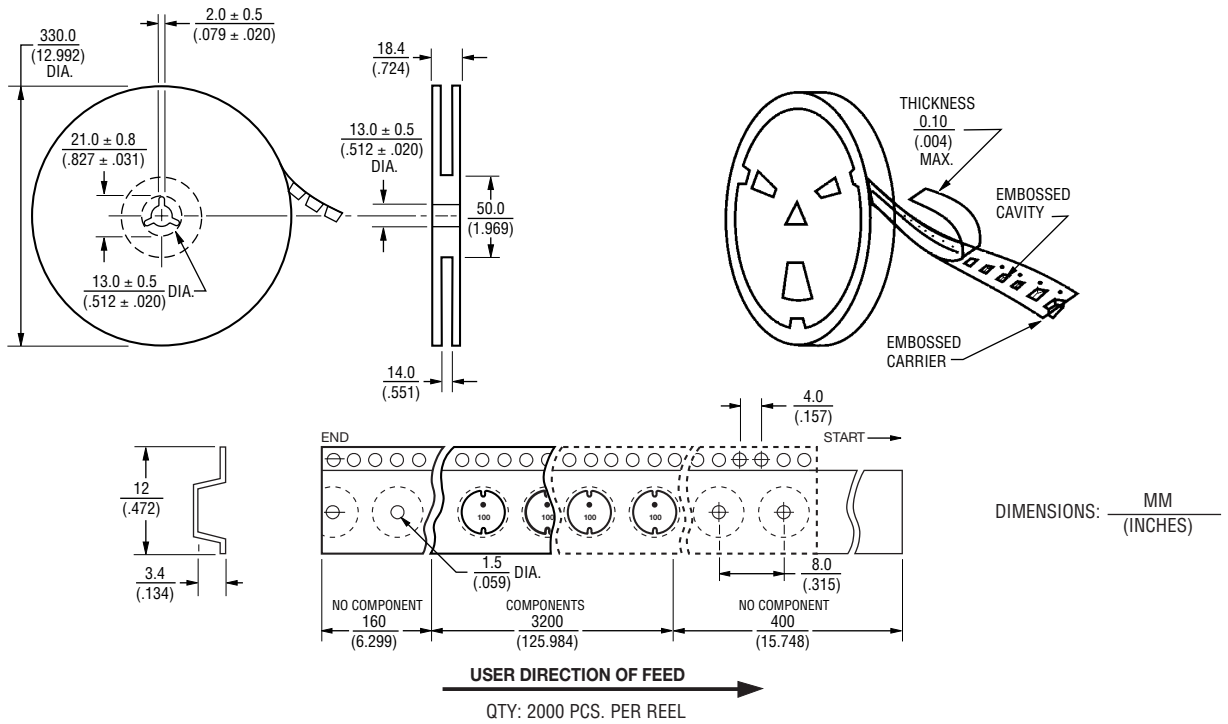



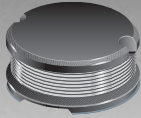

**BOURNS®**

## Features

- Available in E12 series
- Low profile of only 3.3 mm
- High inductance of 15 mH
- RoHS compliant\*

## Applications

- Input/output of DC/DC converters
- Power supplies for:
  - Portable communication equipment
  - Camcorders
  - LCD TVs
  - Car radios

# SDR0503 Series - SMD Power Inductors

### Electrical Specifications

Bourns Part No.	Inductance 1kHz		Q Ref.	Test Frequency (MHz)	SRF Min. (MHz)	RDC Max. (Ω)	I rms Max. (A)	I sat Typ. (A)
	(μH)	Tol. %						
SDR0503-100ML	10	± 20	10	2.52	30.0	0.13	1.300	1.600
SDR0503-120ML	12	± 20	20	2.52	29.0	0.16	1.200	1.450
SDR0503-150ML	15	± 20	20	2.52	27.0	0.19	1.050	1.260
SDR0503-180ML	18	± 20	20	2.52	24.0	0.21	0.950	1.300
SDR0503-220ML	22	± 20	20	2.52	22.0	0.28	0.900	1.060
SDR0503-270ML	27	± 20	20	2.52	20.0	0.32	0.800	1.000
SDR0503-330KL	33	± 10	15	2.52	18.0	0.38	0.700	0.850
SDR0503-390KL	39	± 10	15	2.52	17.0	0.42	0.650	0.800
SDR0503-470KL	47	± 10	20	2.52	14.0	0.60	0.600	0.750
SDR0503-560KL	56	± 10	20	2.52	13.0	0.71	0.500	0.700
SDR0503-680KL	68	± 10	20	2.52	12.0	0.76	0.450	0.600
SDR0503-820KL	82	± 10	15	2.52	10.0	0.88	0.420	0.520
SDR0503-101KL	100	± 10	40	0.796	9.0	1.60	0.400	0.480
SDR0503-121KL	120	± 10	40	0.796	8.0	1.70	0.370	0.450
SDR0503-151KL	150	± 10	40	0.796	7.0	2.00	0.330	0.400
SDR0503-181KL	180	± 10	40	0.796	7.0	2.30	0.300	0.350
SDR0503-221KL	220	± 10	35	0.796	6.0	2.50	0.250	0.340
SDR0503-271KL	270	± 10	35	0.796	6.0	2.90	0.230	0.280
SDR0503-331KL	330	± 10	30	0.796	5.0	3.30	0.210	0.280
SDR0503-391KL	390	± 10	30	0.796	5.0	3.70	0.190	0.240
SDR0503-471KL	470	± 10	30	0.796	5.0	4.90	0.180	0.220
SDR0503-561KL	560	± 10	30	0.796	4.0	5.70	0.160	0.190
SDR0503-681KL	680	± 10	30	0.796	4.0	7.50	0.140	0.160
SDR0503-821KL	820	± 10	40	0.796	3.0	10.00	0.120	0.155
SDR0503-102KL	1000	± 10	40	0.252	3.0	11.50	0.110	0.135
SDR0503-122JL	1200	± 5	40	0.252	3.0	12.00	0.063	0.090
SDR0503-152JL	1500	± 5	40	0.252	2.0	13.00	0.059	0.072
SDR0503-182JL	1800	± 5	40	0.252	2.0	15.00	0.055	0.070
SDR0503-222JL	2200	± 5	40	0.252	2.0	22.00	0.053	0.070
SDR0503-272JL	2700	± 5	40	0.252	2.0	26.00	0.050	0.070
SDR0503-332JL	3300	± 5	40	0.252	2.0	38.00	0.045	0.062
SDR0503-392JL	3900	± 5	40	0.252	2.0	40.00	0.042	0.060
SDR0503-472JL	4700	± 5	40	0.252	1.0	48.00	0.040	0.050
SDR0503-562JL	5600	± 5	40	0.252	1.0	72.00	0.038	0.050
SDR0503-682JL	6800	± 5	40	0.252	1.0	80.00	0.034	0.045
SDR0503-822JL	8200	± 5	40	0.252	1.0	92.00	0.030	0.045
SDR0503-103JL	10000	± 5	30	0.0796	1.0	110.00	0.027	0.040
SDR0503-123JL	12000	± 5	30	0.0796	1.0	148.00	0.025	0.038
SDR0503-153JL	15000	± 5	30	0.0796	1.0	168.00	0.020	0.032

### General Specifications

Test Voltage.....1 V  
 Reflow Soldering ...230 °C, 50 sec. max.  
 Operating Temperature...-40 °C to +125 °C  
 (Temperature rise included)  
 Storage Temperature...-40 °C to +125 °C  
 Resistance to Soldering Heat  
 .....260 °C for 5 sec.

### Materials

Core .....Ferrite DR  
 Wire .....Enameled copper  
 Terminal.....Ag/Ni/Sn  
 Rated Current..Ind. drop 10 % typ. at Isat  
 Temperature Rise .....40 °C max.  
 at rated I rms  
 Packaging .....500 pcs. per reel

### Product Dimensions

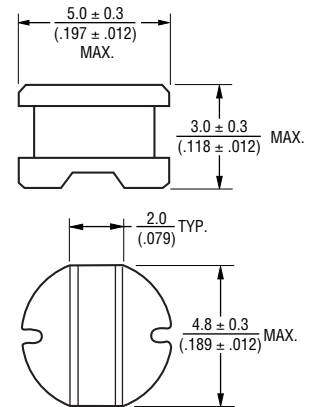

### Recommended Layout

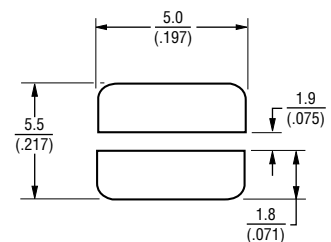

### Typical Part Marking

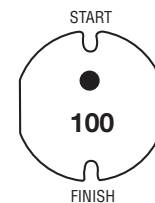

DIMENSIONS:  $\frac{\text{MM}}{\text{(INCHES)}}$

\*RoHS Directive 2002/95/EC Jan 27, 2003 including Annex  
 Specifications are subject to change without notice.  
 Customers should verify actual device performance in their specific applications.

# SDR0503 Series - SMD Power Inductors



## Packaging Specifications

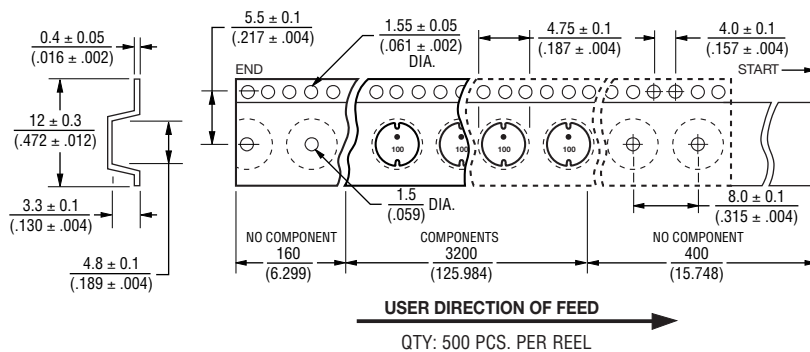
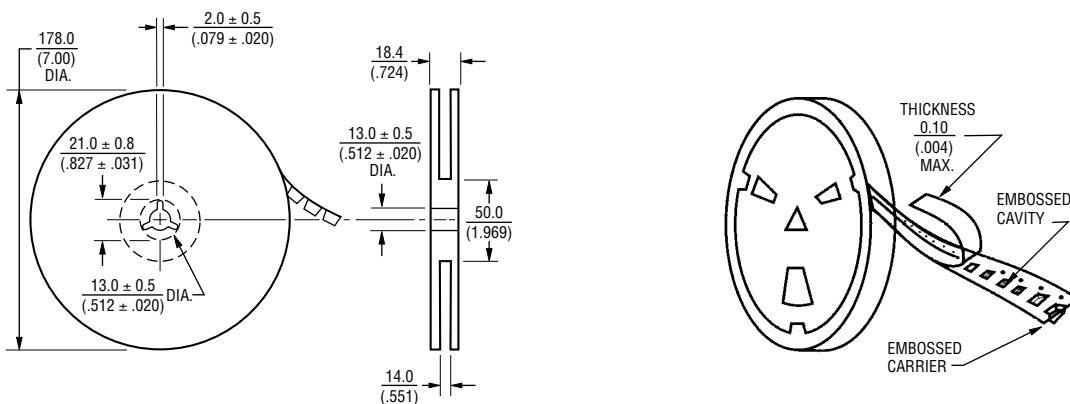

DIMENSIONS:  $\frac{\text{MM}}{\text{(INCHES)}}$

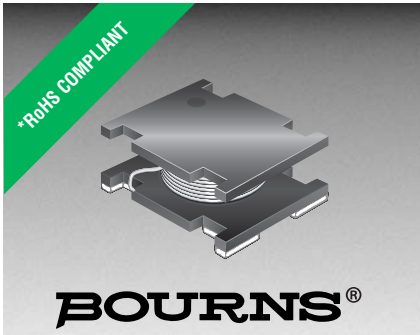

### Features

- Available in E12 series
- Unit height of 2.2 mm
- Current up to 1.5 A
- High Q level
- RoHS compliant\*

### Applications

- Input/output of DC/DC converters
- Power supplies for:
  - Portable communication equipment
  - Camcorders
  - LCD TVs
  - Car radios

## SDR0602 Series - SMD High Power Inductor

### Electrical Specifications

Bourns Part No.	Inductance 1kHz		Q Ref.	Test Frequency (MHz)	SRF Min. (MHz)	RDC Max. (Ω)	I rms Max. (A)	I sat Typ. (A)
	(μH)	Tol. %						
SDR0602-2R7ML	2.7	± 20	20	7.96	40	0.12	1.50	2.10
SDR0602-3R9ML	3.9	± 20	20	7.96	40	0.13	1.40	1.90
SDR0602-4R7ML	4.7	± 20	20	7.96	35	0.15	1.30	1.80
SDR0602-5R6ML	5.6	± 20	18	7.96	30	0.17	1.20	1.60
SDR0602-6R8ML	6.8	± 20	18	7.96	28	0.18	1.15	1.55
SDR0602-8R2ML	8.2	± 20	15	7.96	27	0.20	1.10	1.43
SDR0602-100ML	10	± 20	50	2.52	25	0.24	1.00	1.32
SDR0602-120ML	12	± 20	45	2.52	21	0.26	0.90	1.17
SDR0602-150ML	15	± 20	45	2.52	20	0.28	0.80	1.10
SDR0602-180ML	18	± 20	45	2.52	18	0.30	0.75	1.07
SDR0602-220ML	22	± 20	45	2.52	16	0.40	0.70	0.90
SDR0602-270ML	27	± 20	40	2.52	15	0.45	0.65	0.83
SDR0602-330KL	33	± 10	35	2.52	12	0.50	0.60	0.73
SDR0602-390KL	39	± 10	32	2.52	12	0.65	0.55	0.68
SDR0602-470KL	47	± 10	30	2.52	11	0.68	0.50	0.62
SDR0602-560KL	56	± 10	30	2.52	10	0.78	0.45	0.57
SDR0602-680KL	68	± 10	27	2.52	9	0.85	0.40	0.52
SDR0602-820KL	82	± 10	27	2.52	8	1.30	0.35	0.46
SDR0602-101KL	100	±10	50	0.796	7	1.52	0.32	0.42
SDR0602-121KL	120	± 10	50	0.796	6	1.65	0.30	0.38
SDR0602-151KL	150	± 10	60	0.796	6	2.00	0.26	0.24
SDR0602-181KL	180	± 10	55	0.796	5	2.30	0.23	0.32
SDR0602-221KL	220	± 10	55	0.796	5	2.50	0.20	0.29
SDR0602-271KL	270	± 10	55	0.796	4	2.85	0.18	0.26
SDR0602-331KL	330	± 10	55	0.796	4	3.80	0.16	0.22
SDR0602-391KL	390	± 10	55	0.796	3	4.20	0.15	0.20
SDR0602-471KL	470	± 10	55	0.796	3	5.00	0.14	0.18
SDR0602-561KL	560	± 10	55	0.796	3	6.20	0.12	0.14

### General Specifications

Test Voltage.....1 Volt  
 Reflow Soldering.....260 °C, 50 sec max.  
 Operating Temperature ..-40 °C to +125 °C  
 (Temperature rise included)  
 Storage Temperature...-40 °C to +125 °C  
 Packaging.....800 pcs. per reel  
 Resistance to Soldering Heat  
 .....260 °C for 5 sec.

### Materials

Core Material .....Ferrite DQ  
 Wire .....Enameled Copper  
 Terminal.....Ag/Ni/Sn  
 Rated Current...Ind. drop 10 % typ. at Isat  
 Temperature Rise...40 °C max at rated Irms

### Product Dimensions

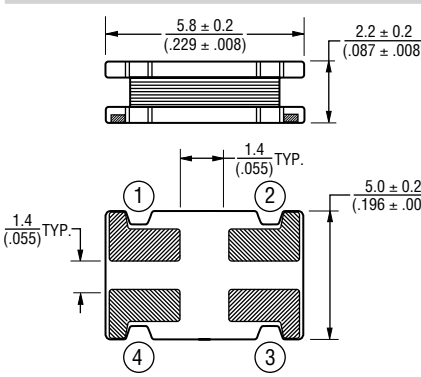

### Recommended Layout

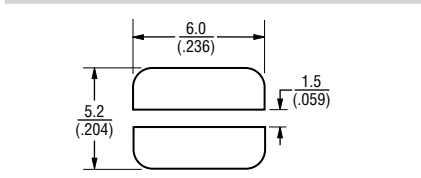

### Typical Part Marking

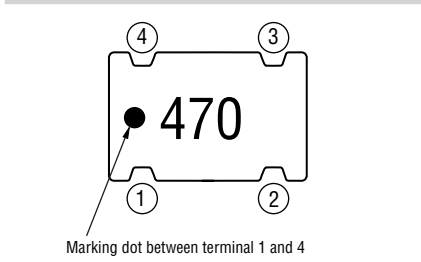

### Electrical Schematic

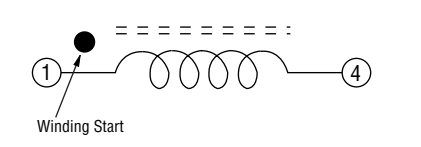

\*RoHS Directive 2002/95/EC Jan 27, 2003 including Annex  
 Specifications are subject to change without notice.  
 Customers should verify actual device performance in their specific applications.

DIMENSIONS:  $\frac{\text{MM}}{\text{(INCHES)}}$

# SDR0602 Series - SMD Power Inductors

**BOURNS®**

## Packaging Specifications

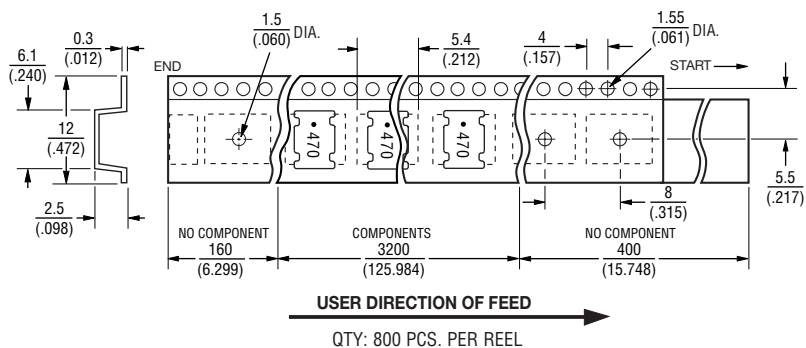
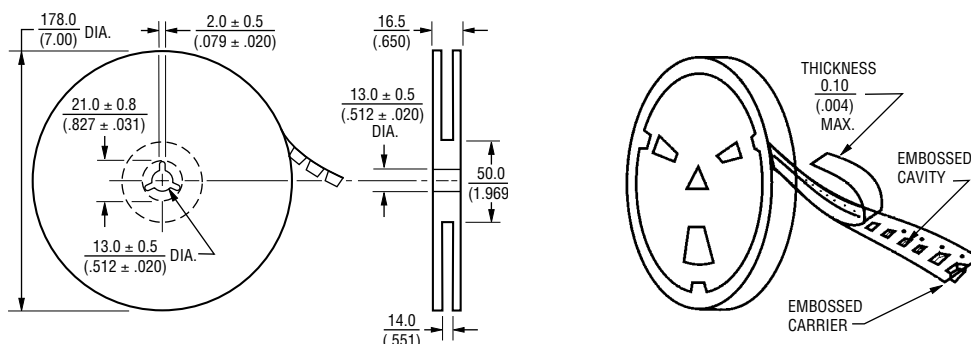

DIMENSIONS:  $\frac{\text{MM}}{\text{(INCHES)}}$



## Features

- Available in E12 series
- Small design of only 5.8 mm maximum diameter
- Low 3.9 mm profile
- RoHS compliant\*

## Applications

- Input/output of DC/DC converters
- Power supplies for:
  - Portable communication equipment
  - Camcorders
  - LCD TVs
  - Car radios

# SDR0603 Series - SMD Power Inductors

### Electrical Specifications

Bourns Part No.	Inductance 1kHz		Q Ref.	Test Frequency (MHz)	SRF Min. (MHz)	RDC Max. ( $\Omega$ )	I rms Max. (A)	I sat Typ. (A)
	( $\mu$ H)	Tol. %						
SDR0603-1R5ML	1.5	$\pm 20$	24	7.96	85	0.04	3.00	3.50
SDR0603-2R5ML	2.5	$\pm 20$	21	7.96	74	0.05	2.35	2.70
SDR0603-3R3ML	3.3	$\pm 20$	21	7.96	68	0.05	2.20	2.60
SDR0603-3R9ML	3.9	$\pm 20$	22	7.96	62	0.05	2.10	2.20
SDR0603-4R7ML	4.7	$\pm 20$	20	7.96	56	0.07	1.80	2.20
SDR0603-5R0ML	5.0	$\pm 20$	19	7.96	50	0.07	1.60	2.10
SDR0603-6R8ML	6.8	$\pm 20$	19	7.96	44	0.11	1.38	1.80
SDR0603-7R5ML	7.5	$\pm 20$	19	7.96	38	0.12	1.29	1.60
SDR0603-100ML	10	$\pm 20$	24	2.52	34	0.15	1.14	1.40
SDR0603-120ML	12	$\pm 20$	23	2.52	30	0.16	1.02	1.30
SDR0603-150ML	15	$\pm 20$	22	2.52	28	0.18	0.93	1.10
SDR0603-180ML	18	$\pm 20$	23	2.52	24	0.25	0.82	1.10
SDR0603-220ML	22	$\pm 20$	20	2.52	30	0.28	0.75	0.96
SDR0603-270ML	27	$\pm 20$	19	2.52	19	0.30	0.67	0.86
SDR0603-330KL	33	$\pm 10$	23	2.52	15	0.45	0.61	0.70
SDR0603-390KL	39	$\pm 10$	22	2.52	13	0.46	0.56	0.66
SDR0603-470KL	47	$\pm 10$	20	2.52	13	0.55	0.52	0.62
SDR0603-560KL	56	$\pm 10$	17	2.52	12	0.62	0.48	0.58
SDR0603-680KL	68	$\pm 10$	17	2.52	12	0.72	0.44	0.54
SDR0603-820KL	82	$\pm 10$	15	2.52	11	0.84	0.40	0.48
SDR0603-101KL	100	$\pm 10$	28	0.796	10	0.95	0.38	0.66
SDR0603-121KL	120	$\pm 10$	27	0.796	8	1.10	0.36	0.60
SDR0603-151KL	150	$\pm 10$	28	0.796	8	1.43	0.32	0.56
SDR0603-181KL	180	$\pm 10$	26	0.796	7	1.60	0.30	0.50
SDR0603-221KL	220	$\pm 10$	26	0.796	6	2.00	0.26	0.46
SDR0603-271KL	270	$\pm 10$	26	0.796	5	2.40	0.24	0.38
SDR0603-331KL	330	$\pm 10$	28	0.796	5	3.20	0.20	0.36
SDR0603-391KL	390	$\pm 10$	28	0.796	4	3.40	0.18	0.32
SDR0603-471KL	470	$\pm 10$	29	0.796	4	4.55	0.15	0.26

### General Specifications

Test Voltage.....1 V  
 Reflow Soldering ...230 °C, 50 sec. max.  
 Operating Temperature ...-40 °C to +125 °C  
 (Temperature rise included)  
 Storage Temperature...-40 °C to +125 °C  
 Resistance to Soldering Heat  
 .....260 °C for 5 sec.

### Materials

Core .....Ferrite DR core  
 Wire .....Enameled copper  
 Terminal.....Ag/Ni/Sn  
 Rated Current..Ind. drop 10 % typ. at Isat  
 Temperature Rise .....40 °C max.  
 at rated Irms  
 Packaging.....400 pcs. per reel

### Product Dimensions

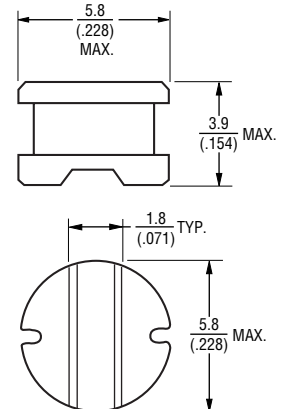

### Recommended Layout

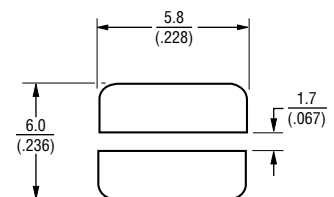

### Typical Part Marking

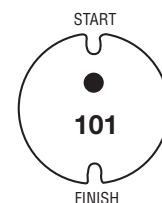

DIMENSIONS:  $\frac{\text{MM}}{\text{(INCHES)}}$

\*RoHS Directive 2002/95/EC Jan 27, 2003 including Annex  
 Specifications are subject to change without notice.  
 Customers should verify actual device performance in their specific applications.

# SDR0603 Series - SMD Power Inductors

**BOURNS®**

## Packaging Specifications

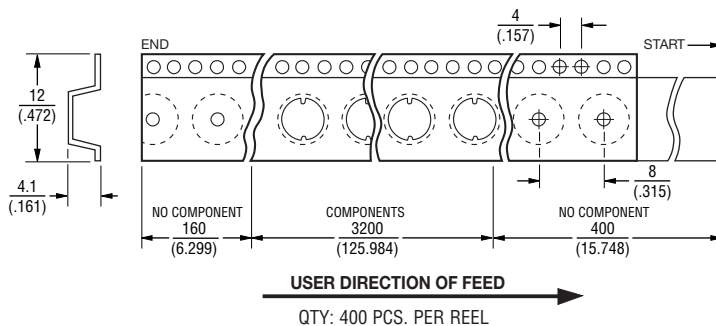
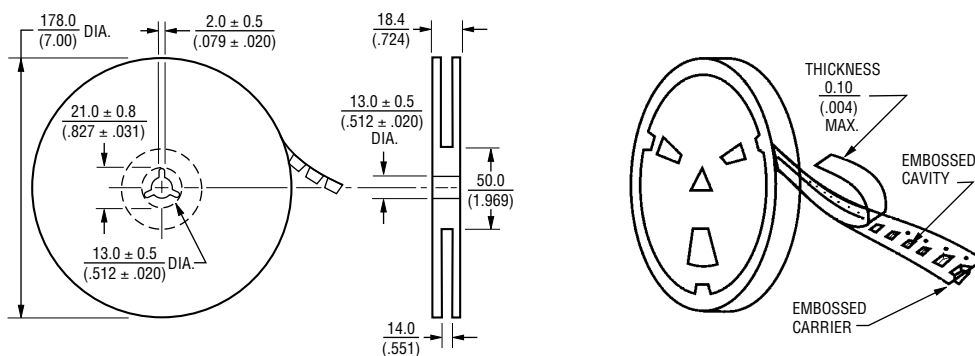

DIMENSIONS:  $\frac{\text{MM}}{\text{(INCHES)}}$



## Features

- Available in E12 series
- Small diameter of only 5.8 mm maximum
- Profile of 4.8 mm
- RoHS compliant\*

## Applications

- Input/output of DC/DC converters
- Power supplies for:
  - Portable communication equipment
  - Camcorders
  - LCD TVs
  - Car radios

# SDR0604 Series - SMD Power Inductors

## Electrical Specifications

Bourns Part No.	Inductance 1kHz		Q Ref.	Test Frequency (MHz)	SRF Min. (MHz)	RDC Max. (Ω)	I rms Max. (A)	I sat Typ. (A)
	(μH)	Tol. %						
SDR0604-1R2ML	1.2	± 20	35	7.96	155	0.02	4.2	7.30
SDR0604-1R5ML	1.5	± 20	32	7.96	108	0.03	3.60	6.10
SDR0604-2R2ML	2.2	± 20	33	7.96	79	0.06	2.80	5.10
SDR0604-2R7ML	2.7	± 20	22	7.96	65	0.06	2.30	3.80
SDR0604-3R3ML	3.3	± 20	22	7.96	60	0.07	2.00	3.50
SDR0604-3R9ML	3.9	± 20	22	7.96	40	0.07	1.90	3.20
SDR0604-4R7ML	4.7	± 20	20	7.96	34	0.08	1.80	3.00
SDR0604-5R6ML	5.6	± 20	20	7.96	30	0.08	1.70	2.70
SDR0604-6R8ML	6.8	± 20	20	7.96	28	0.12	1.60	2.50
SDR0604-8R2ML	8.2	± 20	20	7.96	26	0.09	1.50	2.30
SDR0604-100ML	10	± 20	30	2.52	23	0.10	1.45	2.00
SDR0604-120ML	12	± 20	30	2.52	22	0.12	1.40	1.90
SDR0604-150YL	15	± 15	30	2.52	20	0.14	1.30	1.60
SDR0604-180YL	18	± 15	30	2.52	18	0.15	1.25	1.50
SDR0604-220YL	22	± 15	30	2.52	16	0.19	1.10	1.40
SDR0604-270YL	27	± 15	28	2.52	14	0.22	1.00	1.30
SDR0604-330KL	33	± 10	24	2.52	13	0.25	0.88	1.10
SDR0604-390KL	39	± 10	24	2.52	13	0.32	0.80	1.00
SDR0604-470KL	47	± 10	22	2.52	12	0.37	0.72	1.00
SDR0604-560KL	56	± 10	22	2.52	11	0.42	0.68	0.90
SDR0604-680KL	68	± 10	22	2.52	10	0.52	0.62	0.84
SDR0604-820KL	82	± 10	20	2.52	9	0.60	0.58	0.75
SDR0604-101KL	100	± 10	20	0.796	9	0.70	0.52	0.68
SDR0604-121KL	120	± 10	22	0.796	7	0.93	0.48	0.60
SDR0604-151KL	150	± 10	20	0.796	6	1.10	0.40	0.54
SDR0604-181KL	180	± 10	20	0.796	6	1.38	0.38	0.50
SDR0604-221KL	220	± 10	20	0.796	6	1.57	0.35	0.44
SDR0604-271KL	270	± 10	26	0.796	4	1.88	0.32	0.40
SDR0604-331KL	330	± 10	25	0.796	3	2.25	0.27	0.36
SDR0604-391KL	390	± 10	25	0.796	3	2.48	0.25	0.34
SDR0604-471KL	470	± 10	25	0.796	3	3.30	0.21	0.30
SDR0604-561KL	560	± 10	24	0.252	3	4.00	0.18	0.26
SDR0604-681KL	680	± 10	26	0.252	2	4.65	0.16	0.25
SDR0604-821KL	820	± 10	25	0.252	2	5.20	0.14	0.20
SDR0604-102KL	1000	± 10	45	0.252	1.5	6.80	0.12	0.12

## General Specifications

Test Voltage.....1 V  
 Reflow soldering.....230 °C, 50 sec max.  
 Operating Temperature ..-40 °C to +125 °C  
 (Temperature rise included)  
 Storage Temperature...-40 °C to +125 °C  
 Resistance to Soldering Heat  
 .....260 °C for 5 sec.

## Materials

Core .....Ferrite DR core  
 Wire .....Enameled copper  
 Terminal:.....Ag/Ni/Sn  
 Rated Current..Ind. drop 10 % typ. at Isat  
 Temperature Rise  
 .....40 °C max. at rated I rms  
 Packaging.....400 pcs. per reel

## Product Dimensions

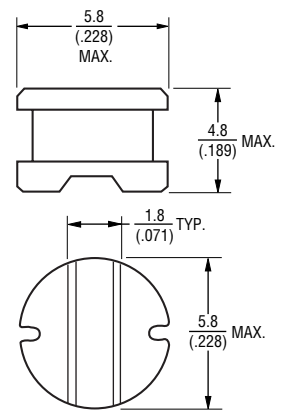

## Recommended Layout

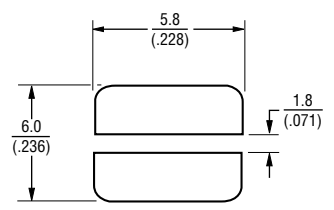

## Typical Part Marking

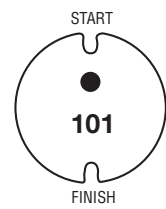

DIMENSIONS:  $\frac{\text{MM}}{\text{(INCHES)}}$

\*RoHS Directive 2002/95/EC Jan 27, 2003 including Annex  
 Specifications are subject to change without notice.  
 Customers should verify actual device performance in their specific applications.

# SDR0604 Series - SMD Power Inductors

**BOURNS®**

## Packaging Specifications

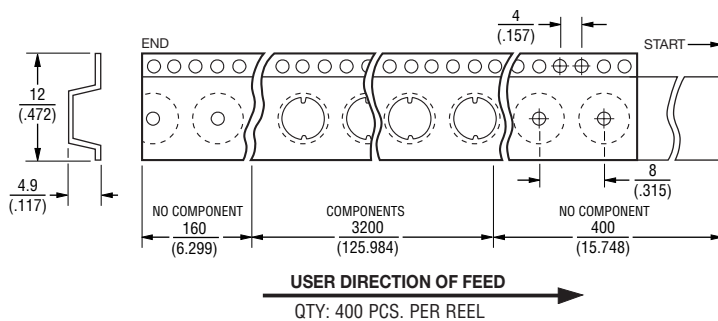
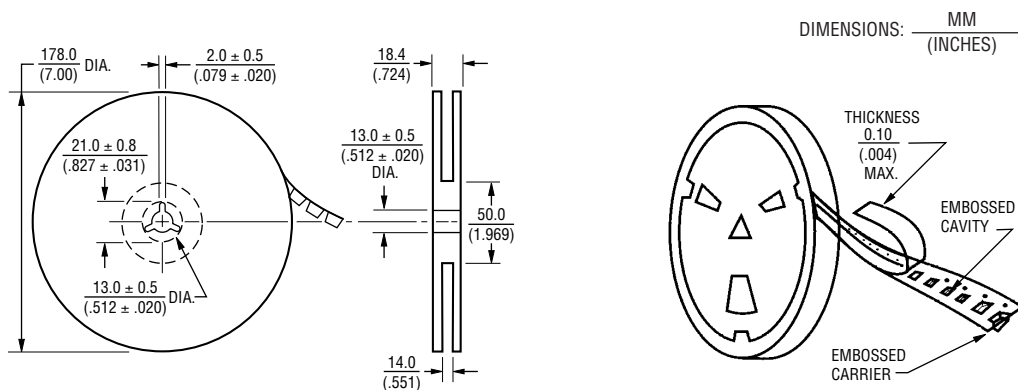





## Features

- Available in E12 series
- Low height of only 2.7 mm
- High Isat of 3.2 Amps
- RoHS compliant\*

## Applications

- Input/output of DC/DC converters
- Power supplies for:
  - Portable communication equipment
  - Camcorders
  - LCD TVs
  - Car radios

# SDR0703 Series - SMD Power Inductors

### Electrical Specifications

Bourns Part No.	Inductance 100 kHz		Q Ref.	Test Frequency (MHz)	SRF Min. (MHz)	RDC Max. (Ω)	I rms Max. (A)	I sat Typ. (A)
	(μH)	Tol. %						
SDR0703-1R0ML	1.0	± 20	25	7.96	160.0	0.042	2.20	3.20
SDR0703-1R2ML	1.2	± 20	25	7.96	145.0	0.047	2.00	3.00
SDR0703-1R8ML	1.8	± 20	25	7.96	105.0	0.052	1.90	2.70
SDR0703-2R2ML	2.2	± 20	24	7.96	95.0	0.060	1.80	2.60
SDR0703-2R7ML	2.7	± 20	23	7.96	80.0	0.065	1.70	2.50
SDR0703-3R3ML	3.3	± 20	23	7.96	65.0	0.075	1.65	2.35
SDR0703-3R9ML	3.9	± 20	22	7.96	70.0	0.080	1.58	2.25
SDR0703-4R7ML	4.7	± 20	20	7.96	60.0	0.100	1.50	2.10
SDR0703-5R6ML	5.6	± 20	20	7.96	56.0	0.105	1.40	2.00
SDR0703-6R8ML	6.8	± 20	20	7.96	45.0	0.115	1.30	1.90
SDR0703-8R2ML	8.2	± 20	20	7.96	40.0	0.150	1.10	1.50
SDR0703-100KL	10	± 10	23	2.52	36.0	0.170	1.00	1.40
SDR0703-120KL	12	± 10	20	2.52	36.0	0.180	0.90	1.30
SDR0703-150KL	15	± 10	23	2.52	30.0	0.240	0.75	1.12
SDR0703-180KL	18	± 10	20	2.52	30.0	0.280	0.70	1.05
SDR0703-220KL	22	± 10	20	2.52	26.0	0.300	0.65	0.95
SDR0703-270KL	27	± 10	20	2.52	20.0	0.400	0.60	0.88
SDR0703-330KL	33	± 10	17	2.52	20.0	0.450	0.56	0.82
SDR0703-390KL	39	± 10	18	2.52	18.0	0.550	0.50	0.73
SDR0703-470KL	47	± 10	20	2.52	15.0	0.720	0.40	0.64
SDR0703-560KL	56	± 10	20	2.52	13.0	0.800	0.39	0.60
SDR0703-680KL	68	± 10	18	2.52	13.0	0.900	0.38	0.56
SDR0703-820KL	82	± 10	18	2.52	12.0	1.18	0.33	0.47
SDR0703-101KL	100	± 10	33	0.796	11.0	1.56	0.27	0.40
SDR0703-121KL	120	± 10	32	0.796	10.0	1.75	0.26	0.37
SDR0703-151KL	150	± 10	30	0.796	9.0	2.00	0.25	0.34
SDR0703-181KL	180	± 10	33	0.796	7.0	2.70	0.19	0.30
SDR0703-221KL	220	± 10	31	0.796	7.0	3.00	0.18	0.28
SDR0703-271KL	270	± 10	30	0.796	7.0	3.60	0.17	0.22
SDR0703-331KL	330	± 10	33	0.796	6.0	4.80	0.16	0.19
SDR0703-391KL	390	± 10	36	0.796	5.5	6.20	0.14	0.18
SDR0703-471KL	470	± 10	33	0.796	5.0	7.00	0.13	0.16
SDR0703-561KL	560	± 10	36	0.796	4.2	9.20	0.11	0.15
SDR0703-681KL	680	± 10	32	0.796	4.0	10.50	0.10	0.15
SDR0703-821KL	820	± 10	32	0.796	3.6	12.00	0.09	0.14
SDR0703-102KL	1000	± 10	30	0.252	3.2	14.20	0.08	0.13

### General Specifications

Test Voltage.....0.1 V  
 Reflow Soldering ...230 °C, 50 sec. max.  
 Operating Temperature ..-40 °C to +125 °C  
 (Temperature rise included)  
 Storage Temperature...-40 °C to +125 °C  
 Resistance to Soldering Heat  
 .....260 °C for 10 sec.

### Materials

Core .....Ferrite  
 Wire .....Enameled copper 130 °C  
 Base.....LCP  
 Adhesive .....6020H-6  
 Terminal .....Ag/Sn  
 Rated Current  
 .....Ind. drop 10 % typ. at Isat  
 Temperature Rise .....20 °C max.  
 at rated Irms  
 Packaging .....500 pcs. per reel

### Product Dimensions

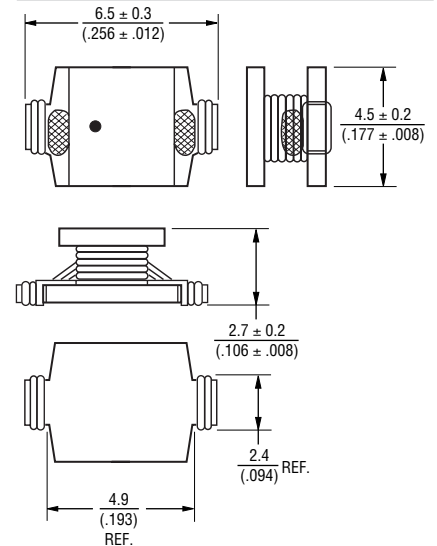

### Recommended Layout

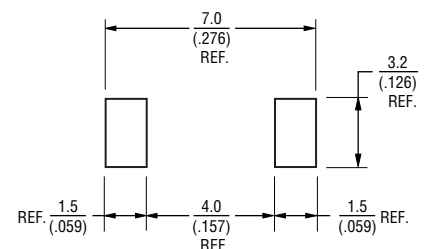

### Electrical Schematic

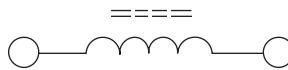

\*RoHS Directive 2002/95/EC Jan 27, 2003 including Annex  
 Specifications are subject to change without notice.  
 Customers should verify actual device performance in their specific applications.

DIMENSIONS:  $\frac{\text{MM}}{\text{(INCHES)}}$

# SDR0703 Series - SMD Power Inductors

**BOURNS®**

## Typical Part Marking

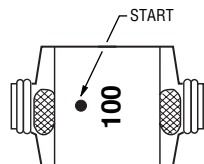

## Packaging Specifications

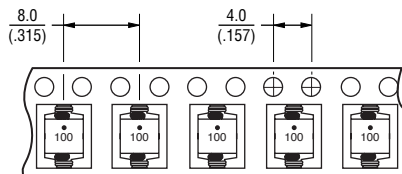
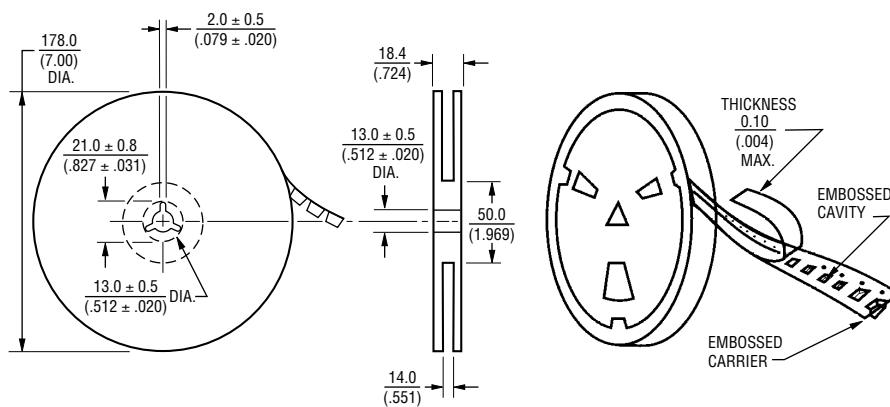

QTY: 500 PCS. PER REEL

DIMENSIONS:  $\frac{\text{MM}}{\text{(INCHES)}}$



### Features

- Available in E12 series
- Small design of only 7.8 mm maximum diameter
- RoHS compliant\*

### Applications

- Input/output of DC/DC converters
- Power supplies for:
  - Portable communications equipment
  - Camcorders
  - LCD TVs
  - CD-players
  - Car radios

## SDR0805 Series - SMD Power Inductors

### Electrical Specifications

Bourns Part No.	Inductance 1kHz		Q Ref.	Test Frequency (MHz)	SRF Min. (MHz)	RDC Max. (Ω)	I rms Max. (A)	I sat Typ. (A)
	(μH)	Tol. %						
SDR0805-1R5ML	1.5	± 20	32	7.96	120	0.02	6.00	9.10
SDR0805-2R5ML	2.5	± 20	32	7.96	70	0.02	5.00	7.20
SDR0805-3R3ML	3.3	± 20	32	7.96	55	0.02	4.50	6.30
SDR0805-3R9ML	3.9	± 20	32	7.96	45	0.02	4.40	5.70
SDR0805-4R7ML	4.7	± 20	31	7.96	38	0.03	3.70	5.00
SDR0805-5R6ML	5.6	± 20	31	7.96	34	0.04	3.50	4.60
SDR0805-6R8ML	6.8	± 20	30	7.96	33	0.04	3.20	4.10
SDR0805-7R5ML	7.5	± 20	29	7.96	30	0.05	2.80	3.70
SDR0805-100ML	10	± 20	25	2.52	22	0.07	2.30	3.20
SDR0805-120ML	12	± 20	25	2.52	20	0.08	2.00	3.00
SDR0805-150ML	15	± 20	25	2.52	16	0.09	1.80	2.70
SDR0805-180ML	18	± 20	20	2.52	15	0.10	1.60	2.60
SDR0805-220ML	22	± 20	20	2.52	13	0.11	1.50	2.30
SDR0805-270KL	27	± 20	20	2.52	12	0.12	1.30	2.10
SDR0805-330KL	33	± 10	15	2.52	10	0.14	1.20	1.90
SDR0805-390KL	39	± 10	15	2.52	10	0.16	1.10	1.70
SDR0805-470KL	47	± 10	15	2.52	9	0.20	1.00	1.60
SDR0805-560KL	56	± 10	15	2.52	9	0.24	0.94	1.50
SDR0805-680KL	68	± 10	15	2.52	8	0.30	0.85	1.30
SDR0805-820KL	82	± 10	12	2.52	7	0.37	0.78	1.20
SDR0805-101KL	100	± 10	12	0.796	7	0.45	0.72	1.10
SDR0805-121KL	120	± 10	12	0.796	6	0.48	0.66	1.00
SDR0805-151KL	150	± 10	12	0.796	6	0.68	0.58	0.85
SDR0805-181KL	180	± 10	12	0.796	5	0.77	0.51	0.80
SDR0805-221KL	220	± 10	12	0.796	5	0.96	0.49	0.80
SDR0805-271KL	270	± 10	12	0.796	5	1.11	0.42	0.66
SDR0805-331KL	330	± 10	12	0.796	4	1.26	0.40	0.58
SDR0805-391KL	390	± 10	12	0.796	4	1.77	0.36	0.55
SDR0805-471KL	470	± 10	12	0.796	4	1.96	0.34	0.50
SDR0805-561KL	560	± 10	30	0.796	4	2.50	0.30	0.46
SDR0805-681KL	680	± 10	29	0.796	3	2.80	0.28	0.42
SDR0805-821KL	820	± 10	28	0.796	3	4.00	0.23	0.35
SDR0805-102KL	1000	± 10	27	0.252	3	4.50	0.21	0.34
SDR0805-122KL	1200	± 10	28	0.252	2	6.80	0.17	0.28
SDR0805-152KL	1500	± 10	27	0.252	2	8.00	0.15	0.26
SDR0805-182KL	1800	± 10	30	0.252	2	9.20	0.14	0.23
SDR0805-222KL	2200	± 10	29	0.252	2	10.00	0.13	0.20
SDR0805-272KL	2700	± 10	31	0.252	1	11.80	0.12	0.18
SDR0805-332KL	3300	± 10	28	0.252	1	16.50	0.10	0.17
SDR0805-392KL	3900	± 10	28	0.252	1	18.00	0.09	0.16
SDR0805-472KL	4700	± 10	30	0.252	1	21.00	0.08	0.15

### General Specifications

Test Frequency .....1 KHz  
 Test Voltage.....1 V  
 Reflow Soldering ...230 °C, 50 sec. max.  
 Operating Temperature ..-40 °C to +125 °C  
 (Temperature rise included)  
 Storage Temperature...-40 °C to +125 °C  
 Resistance to Soldering Heat  
 .....260 °C for 5 sec.

### Materials

Core .....Ferrite DR core  
 Wire .....Enamelled copper wire  
 Terminal.....Ag/Ni/Sn  
 Rated Current  
 .....Ind. drop 10 % typ. at Isat  
 Temperature Rise  
 .....40°C max. at rated Irms  
 Packaging.....1000 pcs. per reel

### Product Dimensions

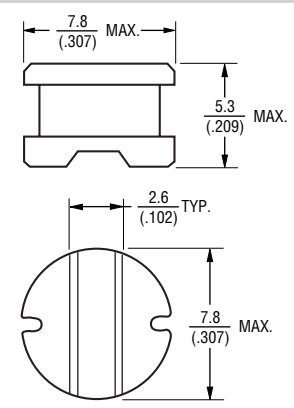

### Recommended Layout

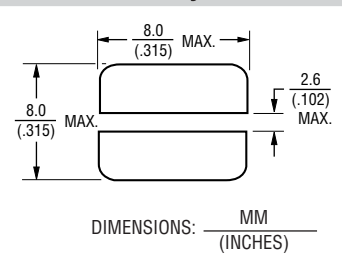

### Typical Part Marking

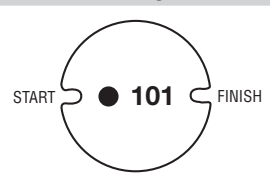

\*RoHS Directive 2002/95/EC Jan 27, 2003 including Annex  
 Specifications are subject to change without notice.  
 Customers should verify actual device performance in their specific applications.

# SDR0805 Series - SMD Power Inductors

**BOURNS®**

## Packaging Specifications

## Materials

Paper  
Plastics

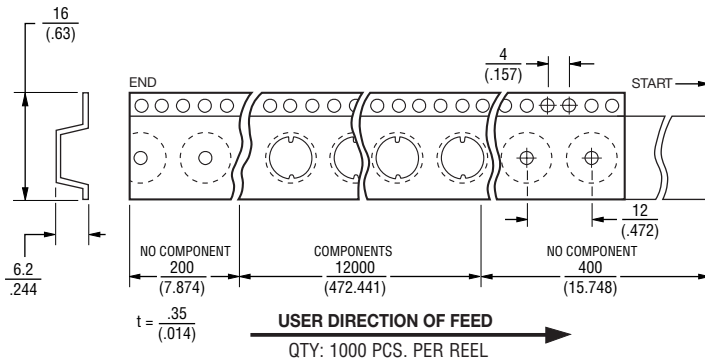
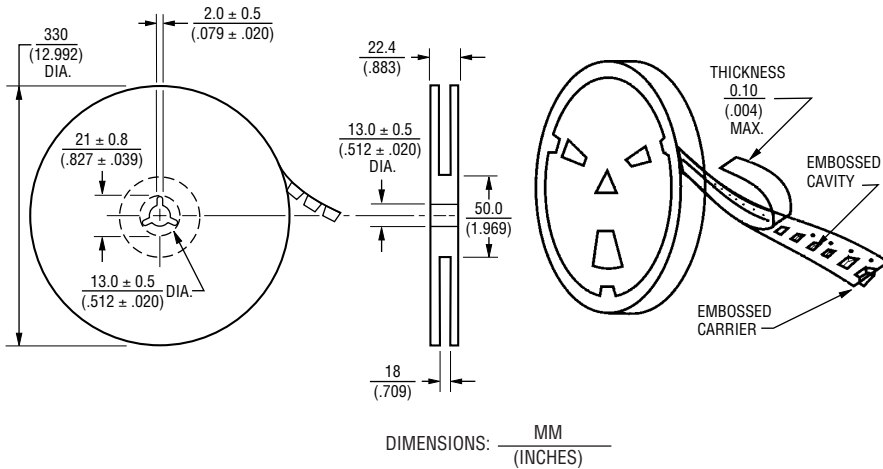

## Strength Of Cover Tape

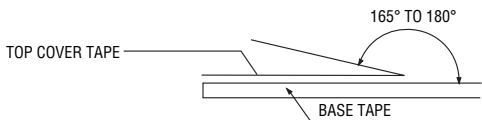

The force for tearing off cover tape is 10 to 130 grams in the arrow direction.

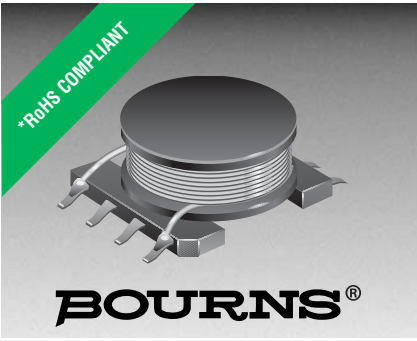

## Features

- High inductance up to 1.2 mH
- E12 series available
- Wide inductance range
- RoHS compliant\*

## Applications

- Input/output of DC/DC converters
- Power supplies for:
  - Portable communications equipment
  - Camcorders
  - LCD TVs
  - Car radios

# SDR0906 Series - SMD Power Inductors

## Electrical Specifications

Bourns Part No.	Inductance 1 kHz		Q Ref.	Test Frequency (MHz)	SRF Min. (MHz)	RDC Max. (Ω)	I rms Max. (A)	I sat Typ. (A)
	(μH)	Tol. %						
SDR0906-2R2ML	2.2	± 20	30	7.96	105	0.03	4.00	6.70
SDR0906-2R7ML	2.7	± 20	30	7.96	84	0.04	3.50	6.50
SDR0906-3R9ML	3.9	± 20	28	7.96	77	0.04	3.30	5.50
SDR0906-4R7ML	4.7	± 20	27	7.96	55	0.05	3.00	4.80
SDR0906-5R6ML	5.6	± 20	28	7.96	42	0.06	2.80	4.50
SDR0906-6R8ML	6.8	± 20	27	7.96	36	0.06	2.60	4.20
SDR0906-8R2ML	8.2	± 20	27	7.96	29	0.07	2.40	4.00
SDR0906-100 ML	10	± 20	35	2.52	25	0.09	2.10	3.20
SDR0906-120 ML	12	± 20	35	2.52	23	0.10	2.00	3.10
SDR0906-150 ML	15	± 20	35	2.52	22	0.11	1.90	2.90
SDR0906-180 ML	18	± 20	35	2.52	19	0.12	1.80	2.40
SDR0906-220 ML	22	± 20	35	2.52	16	0.13	1.60	2.40
SDR0906-270 KL	27	± 10	35	2.52	15	0.15	1.40	2.20
SDR0906-330 KL	33	± 10	35	2.52	14	0.18	1.25	2.00
SDR0906-390 KL	39	± 10	25	2.52	13	0.19	1.15	1.60
SDR0906-470 KL	47	± 10	25	2.52	12	0.23	1.10	1.50
SDR0906-560 KL	56	± 10	25	2.52	12	0.26	1.05	1.40
SDR0906-680 KL	68	± 10	20	2.52	10	0.31	1.00	1.40
SDR0906-820 KL	82	± 10	20	2.52	9	0.33	0.95	1.30
SDR0906-101 KL	100	± 10	15	0.796	8	0.39	0.90	1.10
SDR0906-121 KL	120	± 10	15	0.796	8	0.43	0.85	1.10
SDR0906-151 KL	150	± 10	15	0.796	7	0.56	0.75	0.90
SDR0906-181 KL	180	± 10	15	0.796	6	0.64	0.70	0.82
SDR0906-221 KL	220	± 10	20	0.796	6	0.85	0.60	0.80
SDR0906-271 KL	270	± 10	20	0.796	5	1.00	0.55	0.76
SDR0906-331 KL	330	± 10	15	0.796	5	1.27	0.50	0.65
SDR0906-391 KL	390	± 10	15	0.796	5	1.40	0.45	0.64
SDR0906-471 KL	470	± 10	15	0.796	5	1.63	0.40	0.57
SDR0906-561 KL	560	± 10	15	0.796	4	2.10	0.32	0.53
SDR0906-681 KL	680	± 10	15	0.796	4	2.40	0.28	0.46
SDR0906-821 KL	820	± 10	15	0.796	3	2.75	0.24	0.36
SDR0906-102 KL	1000	± 10	60	0.252	2	3.50	0.22	0.35
SDR0906-122 KL	1200	± 10	60	0.252	2	4.00	0.20	0.28
SDR0906-152 KL	1500	± 10	70	0.252	2	5.00	0.18	0.26
SDR0906-182 KL	1800	± 10	60	0.252	2	5.80	0.17	0.24
SDR0906-222 KL	2200	± 10	94	0.252	2	8.00	0.14	0.23
SDR0906-272 KL	2700	± 10	90	0.252	1	9.00	0.13	0.23
SDR0906-332 KL	3300	± 10	78	0.252	1	10.00	0.12	0.18
SDR0906-392 KL	3900	± 10	96	0.252	1	13.50	0.10	0.18
SDR0906-472 KL	4700	± 10	86	0.252	1	15.00	0.09	0.16
SDR0906-562 KL	5600	± 10	100	0.252	1	20.00	0.07	0.15
SDR0906-682 KL	6800	± 10	90	0.252	1	23.00	0.06	0.14
SDR0906-822 KL	8200	± 10	100	0.252	1	28.00	0.05	0.12
SDR0906-103 KL	10000	± 10	100	0.0796	1	33.00	0.04	0.10

Multiple windings possible (up to four windings).

## Electrical Schematic

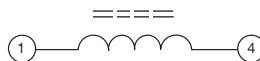

## General Specifications

Test Frequency ..... 1 KHz  
 Test Voltage ..... 1 V  
 Reflow Soldering ... 230 °C, 50 sec. max.  
 Operating Temperature .. -40 °C to +125 °C  
 (Temperature rise included)  
 Storage Temperature .. -40 °C to +125 °C  
 Resistance to Soldering Heat  
 ..... 260 °C for 5 sec.

## Materials

Core ..... Ferrite DR core  
 Wire ..... Enamelled copper wire  
 Base ..... LCP  
 Adhesive ..... Epoxy resin  
 Terminal ..... Cu/Sn  
 Rated Current  
 ..... Ind. drop 10 % typ. at Isat  
 Temperature Rise  
 ..... 40 °C max. at rated I rms  
 Packaging ..... 600 pcs. per reel

## Product Dimensions

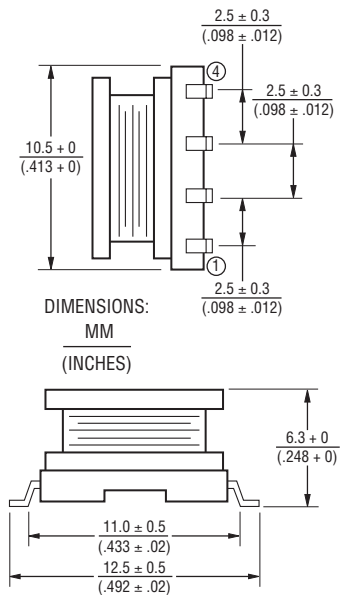

## Recommended Layout

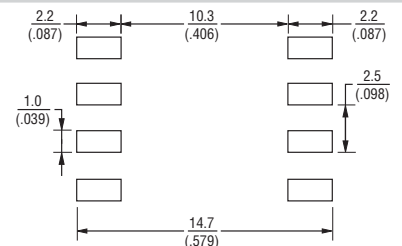

\*RoHS Directive 2002/95/EC Jan 27, 2003 including Annex  
 Specifications are subject to change without notice.  
 Customers should verify actual device performance in their specific applications.

# SDR0906 Series - SMD Power Inductors

**BOURNS®**

## Packaging Specifications

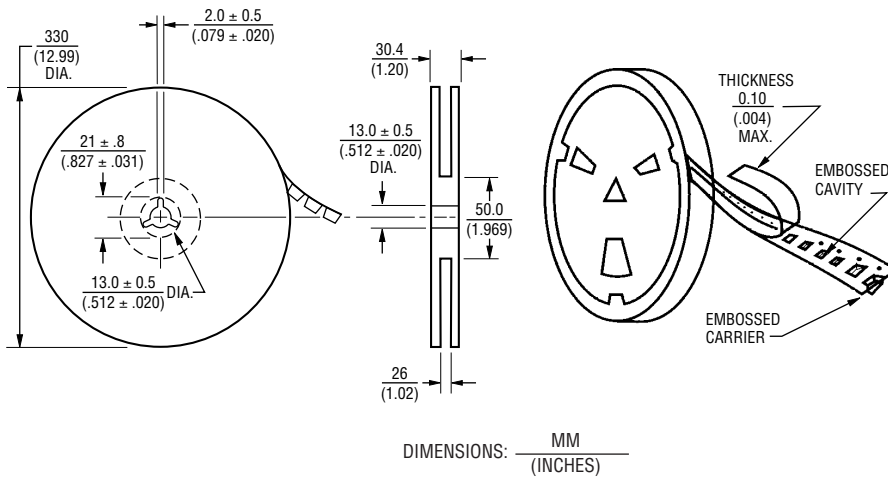

## Materials

Paper  
Plastics

## Typical Part Marking

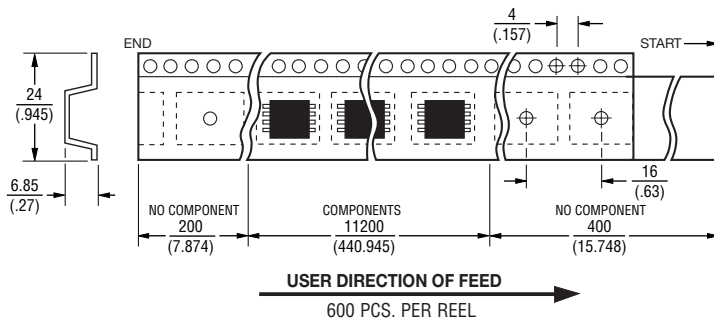
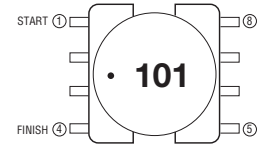

## Strength Of Cover Tape

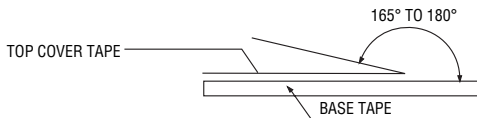

The force for tearing off cover tape is 10 to 130 grams in the arrow direction.



### Features

- Available in E6 series
- Low profile of only 5.0 mm
- Inductance as low as 0.68  $\mu$ H
- RoHS compliant\*

### Applications

- Input/output of DC/DC converters
- Power supplies for:
  - Portable communications equipment
  - Camcorders
  - LCD TVs
  - Car radios

## SDR1005 Series - SMD Power Inductors

### Electrical Specifications

Bourns Part No.	Inductance 1kHz		Q Ref.	Test Frequency Q (MHz)	SRF Min. (MHz)	RDC Max. ( $\Omega$ )	I rms Max. (A)	I sat Typ. (A)
	( $\mu$ H)	Tol. %						
SDR1005-R68ML	0.68	$\pm 20$	26	7.960	160	0.006	8.50	9.50
SDR1005-1R0ML	1	$\pm 20$	55	2.600	137	0.007	7.50	9.00
SDR1005-1R5ML	1.5	$\pm 20$	50	3.000	95	0.009	6.50	8.00
SDR1005-2R2ML	2.2	$\pm 20$	51	2.470	65	0.012	6.10	7.00
SDR1005-2R5ML	2.5	$\pm 20$	49	3.000	56	0.012	5.50	7.00
SDR1005-3R3ML	3.3	$\pm 20$	45	2.520	54	0.015	5.00	6.40
SDR1005-4R7ML	4.7	$\pm 20$	46	2.700	42	0.019	4.50	5.40
SDR1005-6R8ML	6.8	$\pm 20$	56	2.000	31	0.030	3.40	4.50
SDR1005-100ML	10	$\pm 20$	43	4.000	26	0.050	2.90	3.70
SDR1005-150ML	15	$\pm 20$	42	2.700	22	0.060	2.50	3.00
SDR1005-220ML	22	$\pm 20$	29	2.520	18	0.10	2.00	2.50
SDR1005-330KL	33	$\pm 10$	29	2.200	14	0.12	1.80	2.00
SDR1005-470KL	47	$\pm 10$	30	2.200	12	0.19	1.40	1.60
SDR1005-680KL	68	$\pm 10$	24	2.200	11	0.24	1.20	1.40
SDR1005-101KL	100	$\pm 10$	41	0.056	8	0.33	1.00	1.20
SDR1005-151KL	150	$\pm 10$	58	0.087	6	0.59	0.80	1.00
SDR1005-221KL	220	$\pm 10$	50	0.068	5	0.78	0.70	0.80
SDR1005-331KL	330	$\pm 10$	56	0.070	4	1.15	0.55	0.60
SDR1005-471KL	470	$\pm 10$	60	0.081	4	1.70	0.45	0.50
SDR1005-681KL	680	$\pm 10$	72	0.096	3	2.60	0.35	0.40
SDR1005-102KL	1000	$\pm 10$	78	0.122	2	3.90	0.30	0.35
SDR1005-152KL	1500	$\pm 10$	97	0.131	2	6.30	0.25	0.30
SDR1005-222KL	2200	$\pm 10$	85	0.128	2	8.20	0.20	0.24
SDR1005-332KL	3300	$\pm 10$	106	0.128	1	14.00	0.16	0.18
SDR1005-472KL	4700	$\pm 10$	96	0.125	1	17.00	0.15	0.16
SDR1005-682KL	6800	$\pm 10$	105	0.171	1	30.00	0.11	0.12
SDR1005-822KL	8200	$\pm 10$	102	0.145	1	34.00	0.11	0.12
SDR1005-103KL	10000	$\pm 10$	102	0.138	1	39.00	0.10	0.11

### General Specifications

Test Voltage .....0.1 V, 100 KHz  
 Reflow soldering.....250 °C; 10 sec max.  
 (In compliance with JEDEC, J-STD-020C, Table 4-2)  
 Operating Temperature...-40 °C to +125 °C  
 (Temperature rise included)  
 Storage Temperature...-40 °C to +125 °C  
 Resistance to Soldering Heat  
 .....250 °C, 10 sec. max.

### Materials

Core.....Ferrite DR  
 Wire.....Enameled copper  
 Base.....DAP  
 Terminal.....Cu/Sn  
 Rated Current  
 .....Ind. drop 10 % typ. at Isat  
 Temperature Rise .....15 °C max.  
 at rated Irms  
 Packaging.....600 pcs. per reel

### Product Dimensions

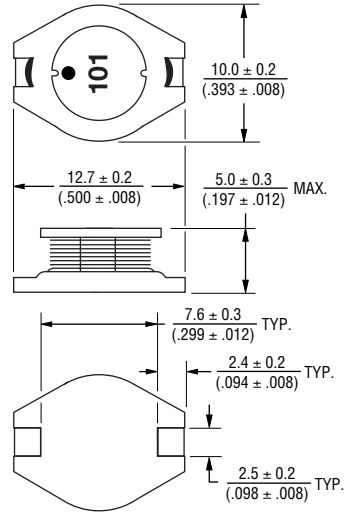

● = START OF WINDING

### Electrical Schematic

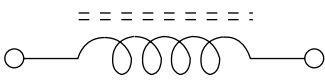

DIMENSIONS:  $\frac{\text{MM}}{\text{(INCHES)}}$

### Recommended Layout

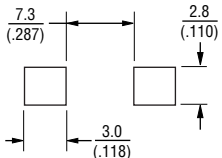

\*RoHS Directive 2002/95/EC Jan 27, 2003 including Annex  
 Specifications are subject to change without notice.  
 Customers should verify actual device performance in their specific applications.

# SDR1005 Series - SMD Power Inductor

**BOURNS®**

## Soldering Profile

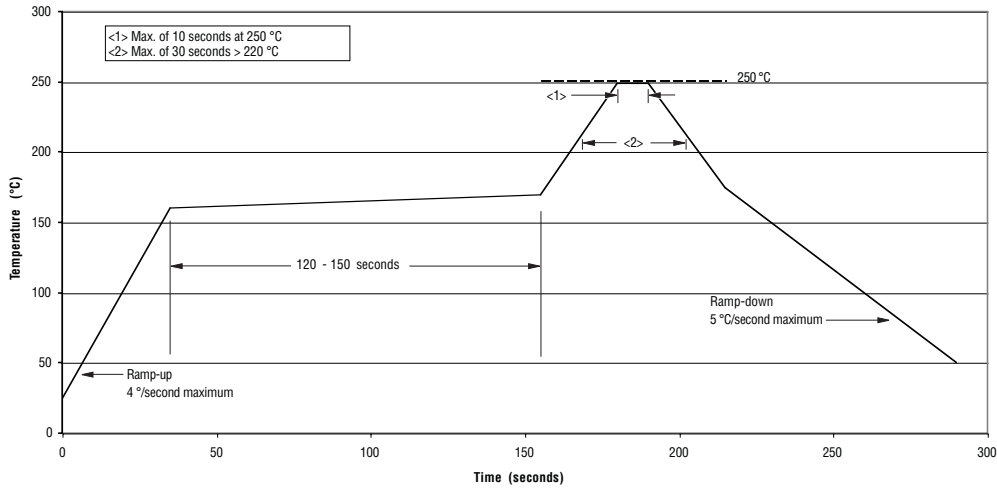

## Packaging Specifications

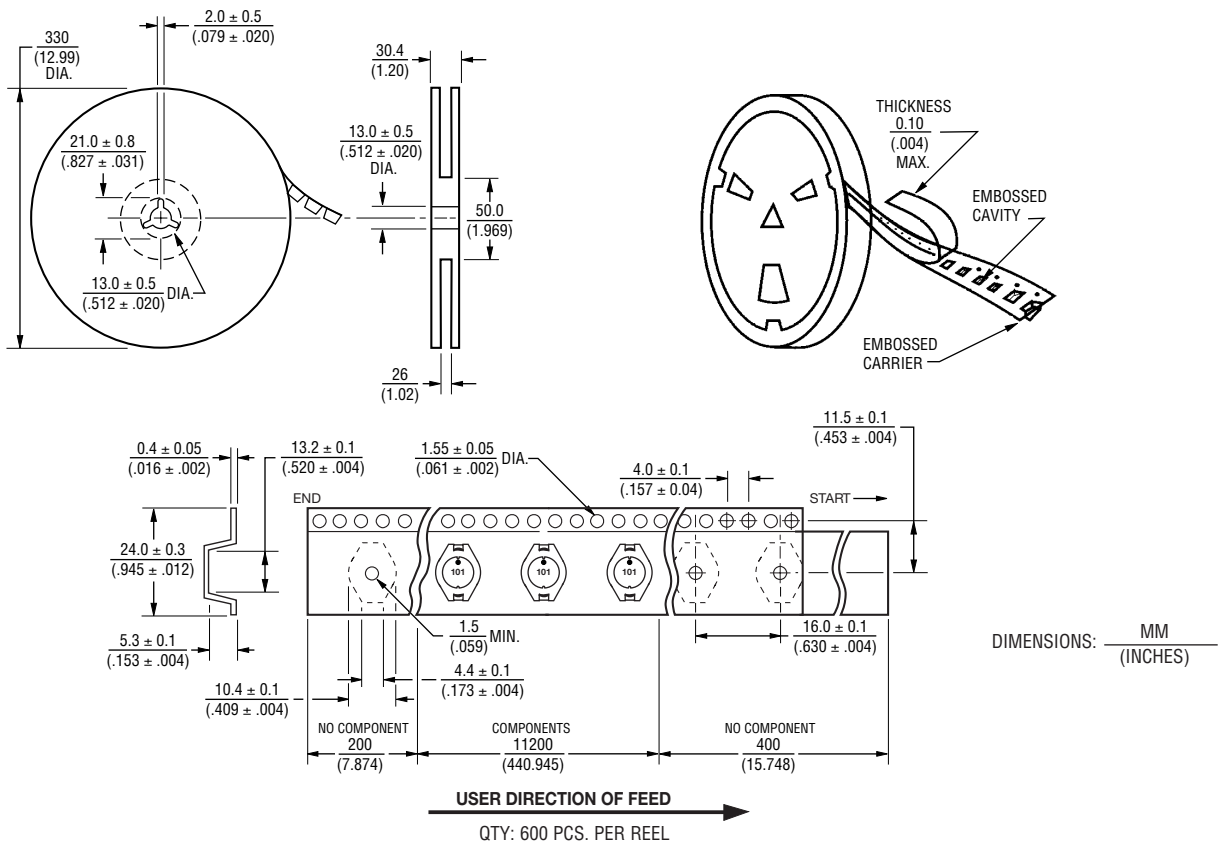

REV. 09/10

Specifications are subject to change without notice.  
Customers should verify actual device performance in their specific applications.





## Features

- Available in E12 series
- Small design of only 9.8 mm maximum diameter
- RoHS compliant\*

## Applications

- Input/output of DC/DC converters
- Power supplies for:
  - Portable communications equipment
  - Camcorders
  - LCD TVs
  - CD-players
  - Car radios

# SDR1006 Series - SMD Power Inductors

### Electrical Specifications

Bourns Part No.	Inductance 1kHz		Q Ref.	Test Frequency (MHz)	SRF Min. (MHz)	RDC Max. (Ω)	I rms Max. (A)	I sat Typ. (A)
	(μH)	Tol. %						
SDR1006-1R5ML	1.5	± 20	35	7.96	105	0.018	6.40	10.00
SDR1006-2R2ML	2.2	± 20	35	7.96	68	0.021	5.40	10.00
SDR1006-3R3ML	3.3	± 20	34	7.96	55	0.024	5.00	10.00
SDR1006-3R9ML	3.9	± 20	34	7.96	48	0.027	4.60	8.40
SDR1006-4R7ML	4.7	± 20	33	7.96	40	0.036	4.00	7.30
SDR1006-5R6ML	5.6	± 20	33	7.96	35	0.040	3.80	6.40
SDR1006-6R8ML	6.8	± 20	33	7.96	32	0.044	3.40	5.90
SDR1006-8R2ML	8.2	± 20	31	7.96	24	0.048	3.00	5.40
SDR1006-100ML	10	± 20	30	2.52	21	0.060	2.60	5.10
SDR1006-120ML	12	± 20	30	2.52	20	0.070	2.45	4.50
SDR1006-150ML	15	± 20	30	2.52	16	0.080	2.25	4.00
SDR1006-180ML	18	± 20	30	2.52	15	0.090	2.15	3.80
SDR1006-220ML	22	± 20	25	2.52	13	0.10	1.95	3.50
SDR1006-270KL	27	± 10	25	2.52	11	0.11	1.75	3.40
SDR1006-330KL	33	± 10	25	2.52	10	0.12	1.50	2.90
SDR1006-390KL	39	± 10	20	2.52	9.0	0.14	1.35	2.60
SDR1006-470KL	47	± 10	20	2.52	8.0	0.17	1.25	2.30
SDR1006-560KL	56	± 10	20	2.52	7.5	0.19	1.15	2.10
SDR1006-680KL	68	± 10	15	2.52	7.0	0.22	1.10	2.00
SDR1006-820KL	82	± 10	15	2.52	6.0	0.25	1.00	1.90
SDR1006-101KL	100	± 10	15	0.796	5.2	0.35	0.97	1.70
SDR1006-121KL	120	± 10	15	0.796	5.0	0.40	0.89	1.50
SDR1006-151KL	150	± 10	15	0.796	4.5	0.47	0.78	1.40
SDR1006-181KL	180	± 10	12	0.796	4.0	0.63	0.72	1.30
SDR1006-221KL	220	± 10	12	0.796	3.8	0.73	0.66	1.10
SDR1006-271KL	270	± 10	12	0.796	3.5	0.97	0.57	1.00
SDR1006-331KL	330	± 10	12	0.796	3.2	1.15	0.52	0.85
SDR1006-391KL	390	± 10	12	0.796	3.0	1.30	0.48	0.80
SDR1006-471KL	470	± 10	12	0.796	2.5	1.48	0.42	0.80
SDR1006-561KL	560	± 10	12	0.796	2.3	1.90	0.33	0.66
SDR1006-681KL	680	± 10	12	0.796	2.1	2.25	0.28	0.65
SDR1006-821KL	820	± 10	10	0.796	2.0	2.55	0.24	0.56
SDR1006-102KL	1000	± 10	30	0.252	1.9	3.10	0.23	0.53
SDR1006-122KL	1200	± 10	31	0.252	1.8	4.20	0.21	0.48
SDR1006-152KL	1500	± 10	31	0.252	1.7	5.00	0.19	0.45
SDR1006-182KL	1800	± 10	31	0.252	1.6	6.80	0.17	0.38
SDR1006-222KL	2200	± 10	31	0.252	1.5	7.60	0.16	0.36
SDR1006-272KL	2700	± 10	32	0.252	1.4	11.60	0.14	0.33
SDR1006-332KL	3300	± 10	32	0.252	1.3	13.50	0.12	0.30
SDR1006-392KL	3900	± 10	32	0.252	1.2	14.80	0.11	0.28
SDR1006-472KL	4700	± 10	32	0.252	0.8	18.00	0.10	0.24

### General Specifications

Test Frequency ..... 1 KHz  
 Test Voltage ..... 1 V  
 Reflow Soldering ... 230 °C, 50 sec. max.  
 Operating Temperature .. -40 °C to +125 °C  
 (Temperature rise included)  
 Storage Temperature .. -40 °C to +125 °C  
 Resistance to Soldering Heat  
 ..... 260 °C for 5 sec.

### Materials

Core ..... Ferrite DR core  
 Wire ..... Enamelled copper wire  
 Terminal ..... Ag/Ni/Sn  
 Rated Current  
 ..... Ind. drop 10 % typ. at Isat  
 Temperature Rise  
 ..... 40 °C max. at rated I rms  
 Packaging ..... 800 pcs. per reel

### Product Dimensions

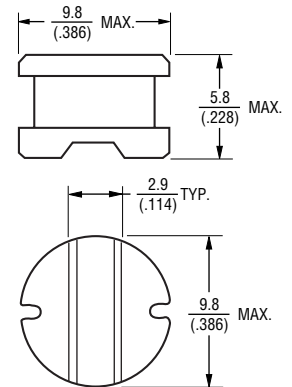

### Recommended Layout

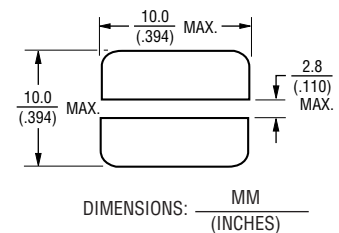

### Typical Part Marking

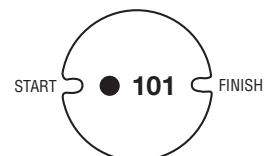

\*RoHS Directive 2002/95/EC Jan 27, 2003 including Annex  
 Specifications are subject to change without notice.  
 Customers should verify actual device performance in their specific applications.

# SDR1006 Series - SMD Power Inductors

**BOURNS®**

## Packaging Specifications

## Materials

Paper  
Plastics

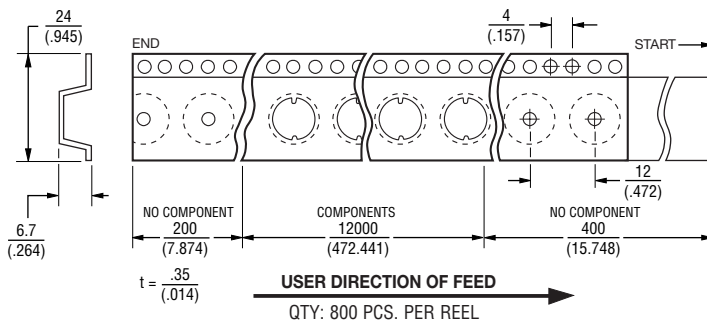
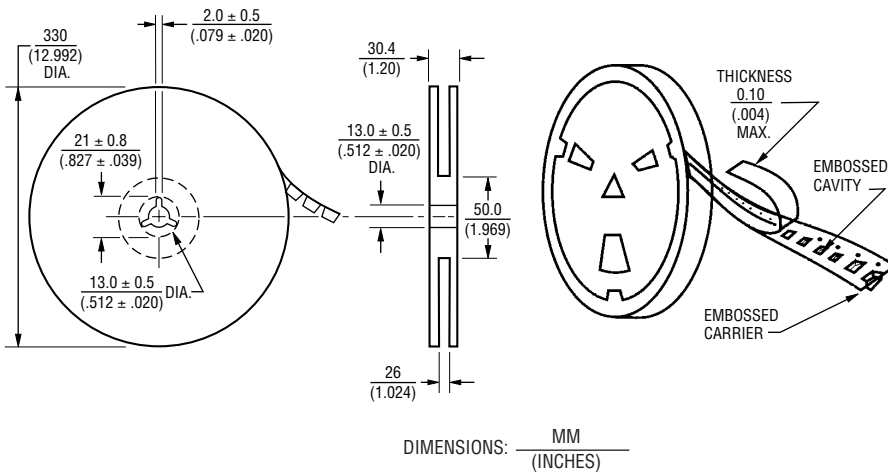

## Strength Of Cover Tape

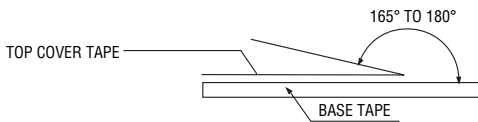

The force for tearing off cover tape is 10 to 130 grams in the arrow direction.

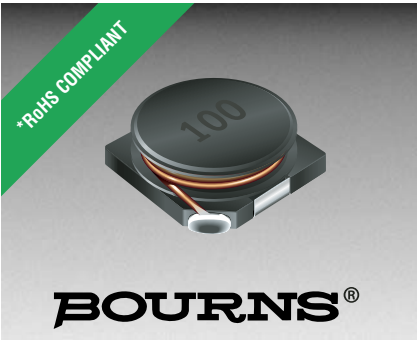

## Features

- Available in E6 values
- Current rating to 3.0 amps
- 3.0 mm height
- Lead free
- RoHS compliant\*

## Applications

- Input/output of DC/DC converters
- Power supplies for:
  - Portable communication equipment
  - Camcorders
  - LCD TVs
  - Car radios

# SDR1030 Series - SMD Power Inductors

### Electrical Specifications

Bourns Part No.	Inductance 100 kHz		Q Typ.	Test Frequency (MHz)	SRF Min. (MHz)	RDC Max. ( $\Omega$ )	I rms Max. (A)	I sat Typ. (A)
	( $\mu$ H)	Tol. %						
SDR1030-2R7M	2.7	$\pm 20$	13	7.96	73.6	0.028	3.00	4.20
SDR1030-4R7M	4.7	$\pm 20$	13	7.96	49.5	0.040	2.60	3.50
SDR1030-6R8M	6.8	$\pm 20$	15	7.96	38.1	0.052	2.20	2.80
SDR1030-100M	10.0	$\pm 20$	15	2.52	33.1	0.064	2.00	2.40
SDR1030-150M	15.0	$\pm 20$	18	2.52	25.7	0.100	1.65	1.85
SDR1030-220M	22.0	$\pm 20$	20	2.52	22.3	0.145	1.38	1.60
SDR1030-330M	33.0	$\pm 20$	16	2.52	16.4	0.220	1.10	1.25
SDR1030-470M	47.0	$\pm 20$	10	2.52	14.2	0.270	0.96	1.10
SDR1030-680M	68.0	$\pm 20$	12	2.52	12.2	0.360	0.82	0.90
SDR1030-101K	100.0	$\pm 10$	14	0.796	9.3	0.540	0.70	0.75
SDR1030-151K	150.0	$\pm 10$	23	0.796	7.9	0.700	0.60	0.58
SDR1030-221K	220.0	$\pm 10$	23	0.796	6.2	1.150	0.46	0.48
SDR1030-331K	330.0	$\pm 10$	25	0.796	5.1	1.700	0.38	0.40
SDR1030-471K	470.0	$\pm 10$	20	0.796	3.8	2.250	0.28	0.32
SDR1030-681K	680.0	$\pm 10$	18	0.796	3.2	3.300	0.23	0.27
SDR1030-102K	1000.0	$\pm 10$	42	0.252	2.5	4.700	0.20	0.23

### General Specifications

Test Voltage .....0.1 V  
 Reflow Soldering ...230 °C, 50 sec. max.  
 Operating Temperature -40 °C to +125 °C  
 (Temperature rise included)  
 Storage Temperature...-40 °C to +125 °C  
 Resistance to Soldering Heat  
 .....260 °C for 10 sec.

### Materials

Core .....Ferrite DR  
 Wire .....Enamelled copper wire 130  
 Terminal.....Cu/Ni/Sn  
 Rated Current  
 .....Ind. drop 10 % typ. at Isat  
 Temperature Rise .....30 °C max.  
 at rated Irms  
 Packaging .....1000 pcs. per reel

### Product Dimensions

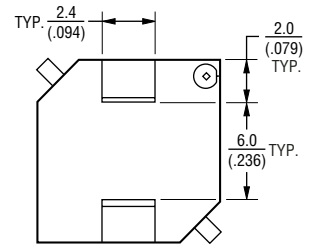
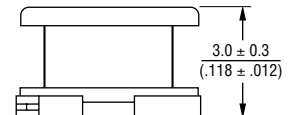
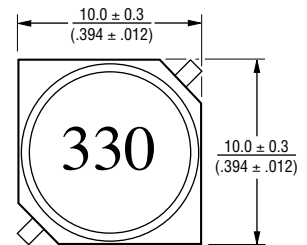

DIMENSIONS:  $\frac{\text{MM}}{\text{(INCHES)}}$

### Electrical Schematic

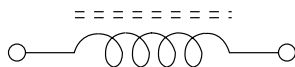

### Recommended Layout

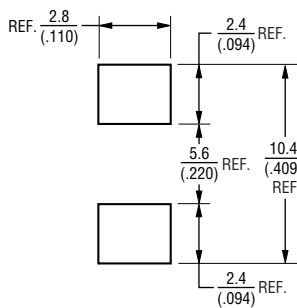

\*RoHS Directive 2002/95/EC Jan 27 2003 including Annex  
 Specifications are subject to change without notice.  
 Customers should verify actual device performance in their specific applications.

# SDR1030 Series - SMD Power Inductors

**BOURNS®**

## Packaging Specifications

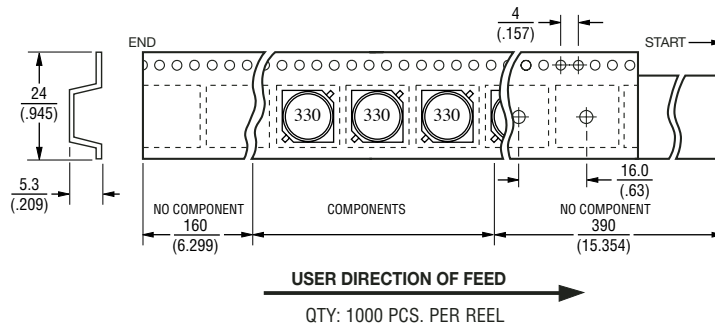
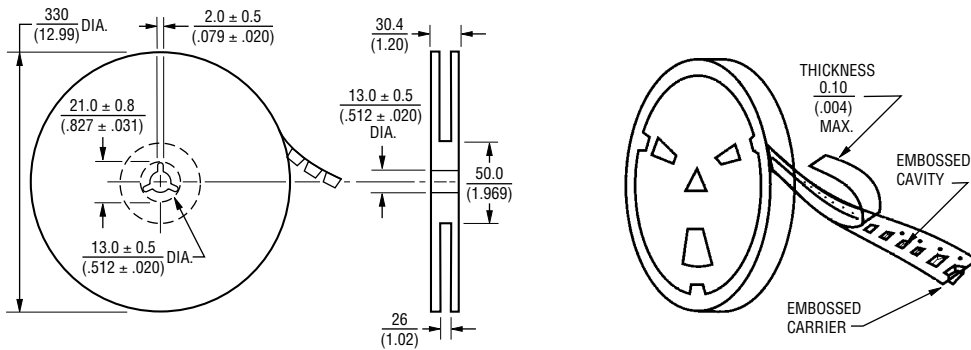

DIMENSIONS:  $\frac{\text{MM}}{\text{(INCHES)}}$

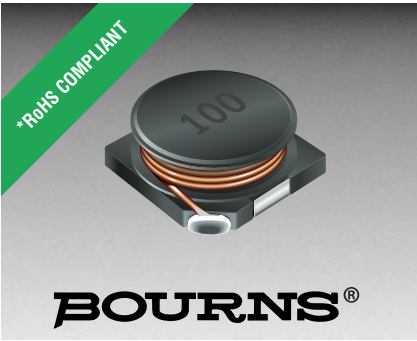

## Features

- Available in E6 values
- Current rating to 4.8 amps
- Mounting height 4.8 mm maximum
- Lead free
- RoHS compliant\*

## Applications

- Input/output of DC/DC converters
- Power supplies for:
  - Portable communication equipment
  - Camcorders
  - LCD TVs
  - Car radios

# SDR1045 Series - SMD Power Inductors

### Electrical Specifications

Bourns Part No.	Inductance 100 kHz		Q Typ.	Test Frequency (MHz)	SRF Min. (MHz)	RDC Max. (Ω)	I rms Max. (A)	I sat Typ. (A)
	(μH)	Tol. %						
SDR1045-2R7M	2.7	± 20	25	7.96	68.7	0.026	4.80	6.20
SDR1045-4R5M	4.5	± 20	25	7.96	44.2	0.033	4.20	5.20
SDR1045-6R8M	6.8	± 20	22	7.96	35.8	0.040	3.50	4.20
SDR1045-100M	10.0	± 20	26	2.52	27.8	0.064	3.20	3.60
SDR1045-150M	15.0	± 20	26	2.52	23.7	0.100	2.50	3.00
SDR1045-220M	22.0	± 20	22	2.52	19.4	0.145	2.20	2.60
SDR1045-330M	33.0	± 20	20	2.52	15.8	0.220	1.90	2.10
SDR1045-470M	47.0	± 20	21	2.52	13.6	0.270	1.60	1.85
SDR1045-680M	68.0	± 20	21	2.52	11.1	0.360	1.30	1.50
SDR1045-101K	100.0	± 10	14	0.796	9.7	0.540	1.10	1.30
SDR1045-151K	150.0	± 10	16	0.796	7.1	0.700	0.85	1.05
SDR1045-221K	220.0	± 10	15	0.796	6.4	1.150	0.72	0.85
SDR1045-331K	330.0	± 10	12	0.796	4.6	1.700	0.62	0.70
SDR1045-471K	470.0	± 10	12	0.796	4.2	2.250	0.52	0.58
SDR1045-681K	680.0	± 10	13	0.796	3.6	3.300	0.43	0.46
SDR1045-102K	1000.0	± 10	25	0.252	2.9	4.700	0.38	0.40

### General Specifications

Test Voltage .....0.1 V  
 Reflow Soldering ...230 °C, 50 sec. max.  
 Operating Temperature  
 .....-40 °C to +125 °C  
 (Temperature rise included)  
 Storage Temperature...-40 °C to +125 °C  
 Resistance to Soldering Heat  
 .....260 °C for 10 sec.

### Materials

Core .....Ferrite DR  
 Wire .....Enamelled copper wire 130  
 Terminal.....Cu/Ni/Sn  
 Rated Current  
 .....Ind. drop 10 % typ. at Isat  
 Temperature Rise .....40 °C max.  
 at rated I rms  
 Packaging .....700 pcs. per reel

### Product Dimensions

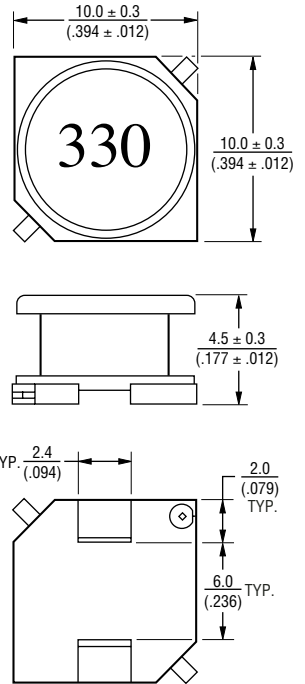

DIMENSIONS:  $\frac{\text{MM}}{\text{(INCHES)}}$

### Electrical Schematic

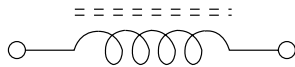

### Recommended Layout

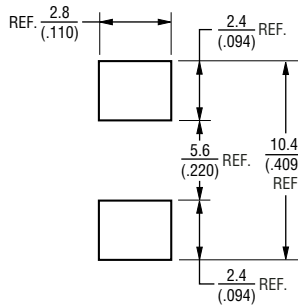

\*RoHS Directive 2002/95/EC Jan 27 2003 including Annex  
 Specifications are subject to change without notice.  
 Customers should verify actual device performance in their specific applications.

# SDR1045 Series - SMD Power Inductors

**BOURNS®**

## Packaging Specifications

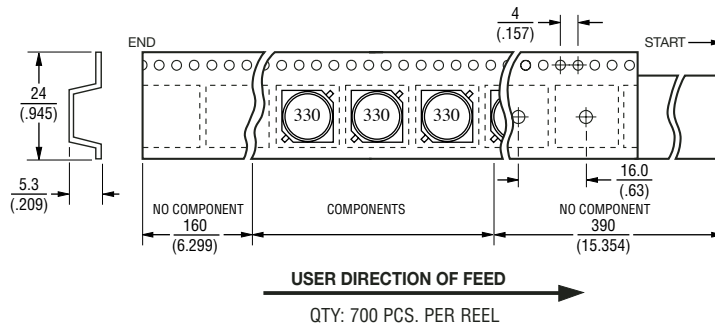
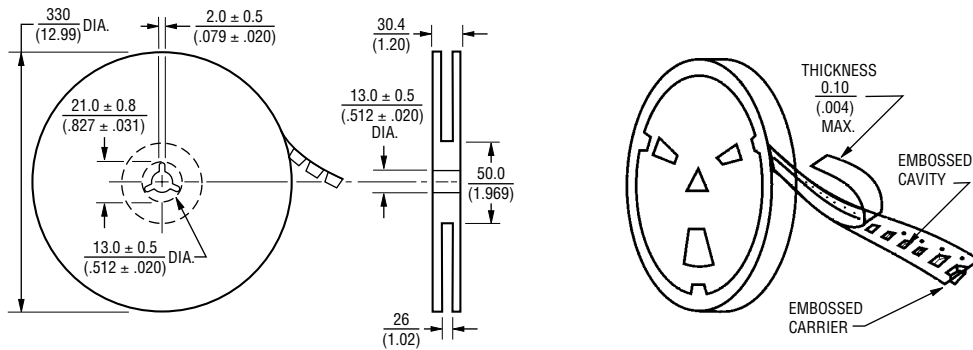

DIMENSIONS:  $\frac{\text{MM}}{\text{(INCHES)}}$



## Features

- Available in E6 series
- Low height of only 4.8 mm
- High Irms of 4.0 amps
- RoHS compliant\*

## Applications

- Input/output of DC/DC converters
- Power supplies for:
  - Portable communications equipment
  - Camcorders
  - LCD TVs
  - CD-players
  - Car radios

**BOURNS®**

# SDR1105 Series - SMD Power Inductors

### Electrical Specifications

Bourns Part No.	Inductance 1kHz		RDC Max. (Ω)	I rms Max. (A)	I sat Typ. (A)
	(μH)	Tol. %			
SDR1105-100ML	10	± 20	0.045	4.00	8.0
SDR1105-120ML	12	± 20	0.048	3.80	8.0
SDR1105-150ML	15	± 20	0.052	3.50	8.0
SDR1105-180ML	18	± 20	0.070	3.30	7.0
SDR1105-220ML	22	± 20	0.080	3.00	6.5
SDR1105-270ML	27	± 20	0.090	2.80	5.0
SDR1105-330KL	33	± 10	0.100	2.60	5.0
SDR1105-390KL	39	± 10	0.140	2.40	4.5
SDR1105-470KL	47	± 10	0.170	2.20	4.0
SDR1105-560KL	56	± 10	0.200	2.00	3.5
SDR1105-680KL	68	± 10	0.210	1.80	3.5
SDR1105-820KL	82	± 10	0.300	1.60	3.0
SDR1105-101KL	100	± 10	0.320	1.50	2.8
SDR1105-151KL	150	± 10	0.500	1.20	2.3
SDR1105-201KL	200	± 10	0.650	1.00	1.8

### General Specifications

Test Frequency ..... 1 KHz  
 Test Voltage..... 1 V  
 Reflow Soldering ... 230 °C, 50 sec. max.  
 Operating Temperature .. -40 °C to +125 °C  
 (Temperature rise included)  
 Storage Temperature... -40 °C to +125 °C  
 Resistance to Soldering Heat  
 ..... 260 °C for 5 sec.

### Materials

Core ..... Ferrite DR core  
 Wire ..... Enamelled copper wire  
 Base..... FR-4  
 Terminal..... Cu/Ni/Au  
 Rated Current  
 ..... Ind. drop 10 % typ. at Isat  
 Temperature Rise  
 ..... 40 °C max. at rated Irms  
 Packaging..... 800 pcs. per reel

### Electrical Schematic

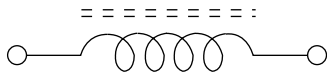

### Packaging Specifications

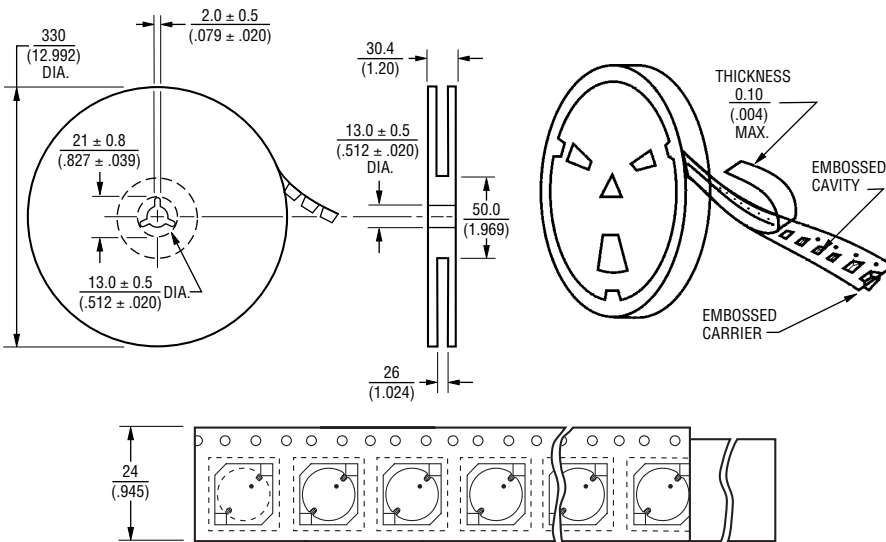

QTY: 800 PCS. PER REEL

DIMENSIONS: MM (INCHES)

### Product Dimensions

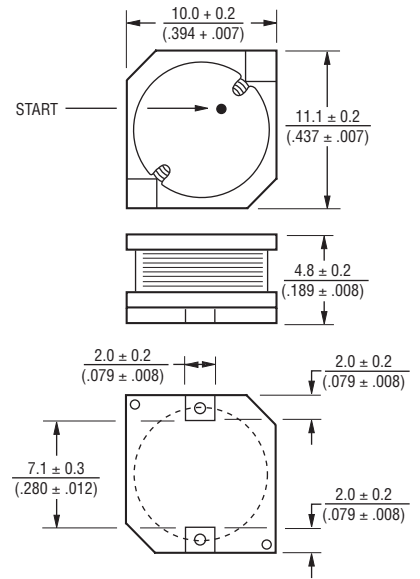

### Recommended Layout

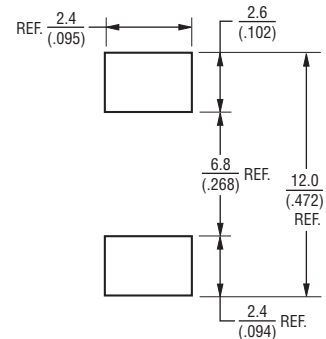

REV. 09/10

\*RoHS Directive 2002/95/EC Jan 27, 2003 including Annex  
 Specifications are subject to change without notice.  
 Customers should verify actual device performance in their specific applications.

\*RoHS COMPLIANT

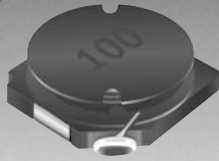

**BOURNS®**

### Features

- Available in E6 values
- Current rating to 7.2 amps
- Lead free
- RoHS compliant\*

### Applications

- Input/output of DC/DC converters
- Power supplies for:
  - Portable communication equipment
  - Camcorders
  - LCD TVs
  - Car radios

## SDR1305 Series - SMD Power Inductors

### Electrical Specifications

Bourns Part No.	Inductance 100 kHz		Q Typ.	Test Frequency (MHz)	SRF Min. (MHz)	RDC Max. (Ω)	I rms Max. (A)	I sat Typ. (A)
	(μH)	Tol. %						
SDR1305-2R5Y	2.5	± 25	19	7.96	61	0.0098	7.20	8.00
SDR1305-3R5Y	3.5	± 25	20	7.96	43	0.0105	6.00	7.00
SDR1305-4R6Y	4.6	± 25	18	7.96	35	0.0165	5.20	6.00
SDR1305-6R8Y	6.8	± 25	17	7.96	32	0.0240	4.30	5.20
SDR1305-100M	10.0	± 20	35	2.52	27	0.0370	3.60	4.40
SDR1305-150M	15.0	± 20	28	2.52	24	0.0460	3.30	3.70
SDR1305-220M	22.0	± 20	27	2.52	20	0.0620	2.90	3.00
SDR1305-330M	33.0	± 20	23	2.52	16	0.0850	2.50	2.60
SDR1305-470M	47.0	± 20	24	2.52	13	0.1300	1.90	2.00
SDR1305-680M	68.0	± 20	22	2.52	11	0.1650	1.65	1.80
SDR1305-101K	100.0	± 10	20	0.796	11	0.2550	1.40	1.40
SDR1305-151K	150.0	± 10	17	0.796	8	0.3800	1.20	1.15
SDR1305-221K	220.0	± 10	16	0.796	7	0.5000	1.00	0.95
SDR1305-331K	330.0	± 10	11	0.796	6	0.7000	0.85	0.80
SDR1305-471K	470.0	± 10	14	0.796	4	1.1500	0.67	0.70
SDR1305-681K	680.0	± 10	12	0.796	3.5	1.4000	0.60	0.58
SDR1305-102K	1000.0	± 10	41	0.252	2.7	2.3500	0.46	0.47

### General Specifications

Test Voltage.....10 mV  
 Reflow Soldering ...230 °C, 50 sec. max.  
 Operating Temperature -40 °C to +125 °C  
 (Temperature rise included)  
 Storage Temperature...-40 °C to +125 °C  
 Resistance to Soldering Heat  
 .....260 °C for 10 sec.

### Materials

Core .....Ferrite DR  
 Wire .....Enamelled copper wire 130  
 Terminal .....Cu/Sn  
 Rated Current  
 .....Ind. drop 25 % typ. at Isat  
 Temperature Rise .....40 °C max.  
 at rated Irms  
 Packaging .....600 pcs. per reel

### Product Dimensions

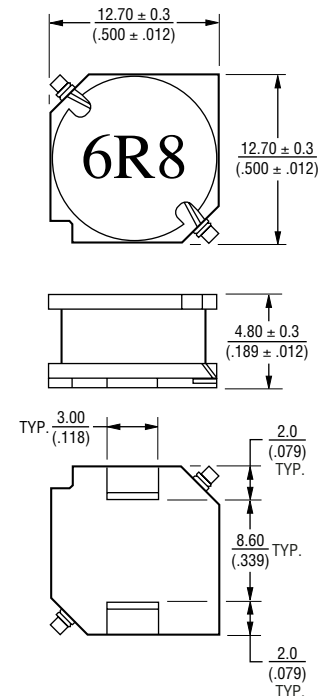

DIMENSIONS:  $\frac{\text{MM}}{\text{(INCHES)}}$

### Electrical Schematic

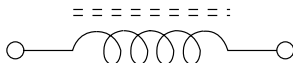

### Recommended Layout

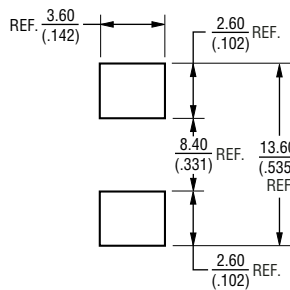

\*RoHS Directive 2002/95/EC Jan 27 2003 including Annex  
 Specifications are subject to change without notice.  
 Customers should verify actual device performance in their specific applications.



# SDR1305 Series - SMD Power Inductors

**BOURNS®**

## Packaging Specifications

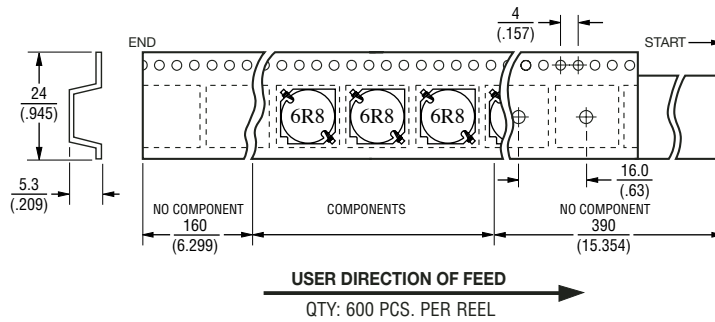
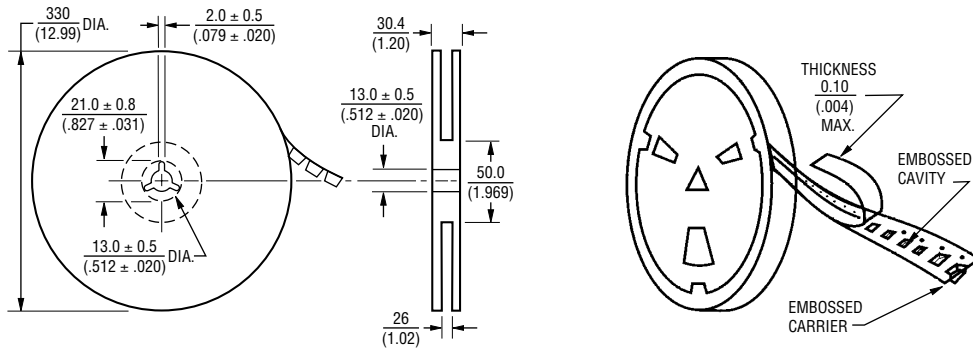

DIMENSIONS:  $\frac{\text{MM}}{\text{(INCHES)}}$

REV. 05/05

Specifications are subject to change without notice.  
Customers should verify actual device performance in their specific applications.



## Features

- Available in E12 series
- Small design of only 13 mm maximum diameter
- RoHS compliant\*

## Applications

- Input/output of DC/DC converters
- Power supplies for:
  - Portable communications equipment
  - Camcorders
  - LCD TVs
  - CD players
  - Car radios

# SDR1307 Series - SMD Power Inductors

## Electrical Specifications

Bourns Part No.	Inductance 100 kHz		Q Ref.	Test Frequency (MHz)	SRF Min. (MHz)	RDC Max. (mΩ)	I rms Max. (A)	I sat Typ. (A)
	(μH)	Tol. %						
SDR1307-1R5ML	1.5	± 20	20	7.96	65.0	5.0	9.50	20.00
SDR1307-2R2ML	2.2	± 20	22	7.96	50.0	6.0	9.00	18.00
SDR1307-2R7ML	2.7	± 20	24	7.96	40.0	8.0	8.20	16.00
SDR1307-3R3ML	3.3	± 20	26	7.96	38.0	8.7	7.50	15.00
SDR1307-4R7ML	4.7	± 20	25	7.96	36.0	10.0	7.00	13.00
SDR1307-5R6ML	5.6	± 20	24	7.96	28.0	15.0	6.50	11.00
SDR1307-6R8ML	6.8	± 20	24	7.96	26.0	17.0	6.00	10.50
SDR1307-8R2ML	8.2	± 20	24	7.96	24.0	19.0	5.80	9.80
SDR1307-100ML	10	± 20	22	2.52	22.0	21.0	5.60	9.20
SDR1307-120ML	12	± 20	25	2.52	20.0	30.0	4.80	8.00
SDR1307-150ML	15	± 20	28	2.52	17.0	34.0	4.50	7.50
SDR1307-180ML	18	± 20	28	2.52	16.0	36.0	4.20	7.00
SDR1307-220ML	22	± 20	40	2.52	15.0	47.0	3.60	6.50
SDR1307-270ML	27	± 20	35	2.52	11.0	60.0	3.30	5.50
SDR1307-330KL	33	± 10	35	2.52	10.0	65.0	3.10	5.00
SDR1307-390KL	39	± 10	28	2.52	9.0	75.0	2.90	4.60
SDR1307-470KL	47	± 10	24	2.52	7.5	82.0	2.70	4.20
SDR1307-560KL	56	± 10	22	2.52	7.2	95.0	2.50	3.80
SDR1307-680KL	68	± 10	24	2.52	7.0	120.0	2.30	3.50
SDR1307-820KL	82	± 10	18	2.52	6.0	140.0	2.10	3.20
SDR1307-101KL	100	± 10	25	0.796	5.8	180.0	1.90	3.00
SDR1307-121KL	120	± 10	20	0.796	5.5	210.0	1.80	2.80
SDR1307-151KL	150	± 10	20	0.796	4.5	250.0	1.60	2.60
SDR1307-181KL	180	± 10	18	0.796	4.0	280.0	1.50	2.30
SDR1307-221KL	220	± 10	15	0.796	3.8	360.0	1.30	2.10
SDR1307-271KL	270	± 10	15	0.796	3.5	410.0	1.20	1.80
SDR1307-331KL	330	± 10	15	0.796	3.2	520.0	1.10	1.60
SDR1307-391KL	390	± 10	12	0.796	2.5	600.0	1.00	1.50
SDR1307-471KL	470	± 10	12	0.796	2.2	720.0	0.90	1.40
SDR1307-561KL	560	± 10	10	0.796	2.0	880.0	0.85	1.30
SDR1307-681KL	680	± 10	10	0.796	1.6	1000.0	0.80	1.20
SDR1307-821KL	820	± 10	10	0.796	1.5	1300.0	0.75	1.10
SDR1307-102KL	1000	± 10	10	0.252	1.4	1600.0	0.65	1.00

## General Specifications

Test Voltage.....0.1 V  
 Reflow Soldering ...230 °C, 50 sec. max.  
 Operating Temperature ..-40 °C to +125 °C  
 (Temperature rise included)  
 Storage Temperature..-40 °C to +125 °C  
 Resistance to Soldering Heat  
 .....260 °C for 5 sec.

## Materials

Core .....Ferrite DR core  
 Wire .....Enamelled copper wire  
 Terminal.....Ag/Ni/Sn  
 Rated Current  
 .....Ind. drop 10 % typ. at Isat  
 Temperature Rise  
 .....40 °C max. at rated I rms  
 Packaging.....400 pcs. per reel

## Product Dimensions

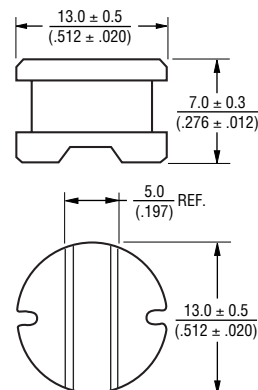

## Recommended Layout

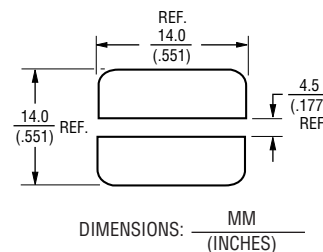

## Electrical Schematic



## Typical Part Marking

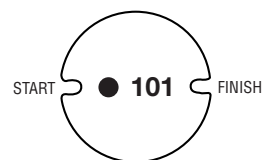

\*RoHS Directive 2002/95/EC Jan 27, 2003 including Annex  
 Specifications are subject to change without notice.  
 Customers should verify actual device performance in their specific applications.

# SDR1307 Series - SMD Power Inductors

**BOURNS®**

## Packaging Specifications

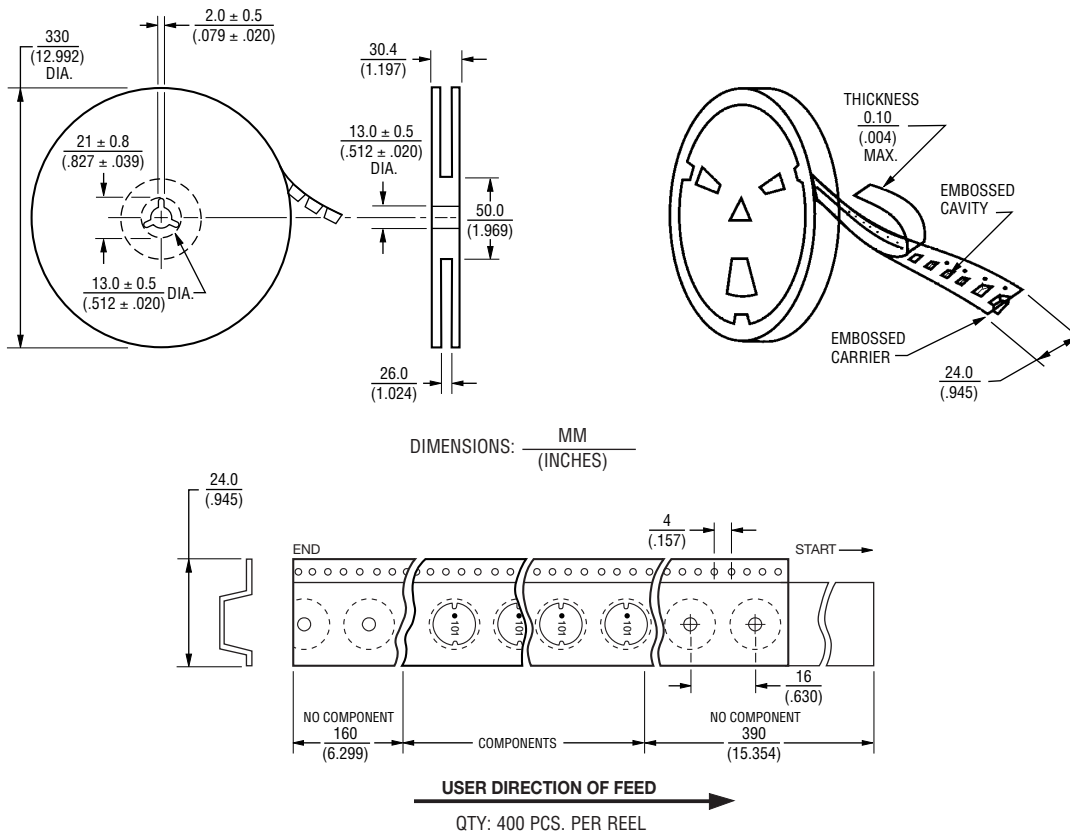

REV. 09/10

Specifications are subject to change without notice.  
Customers should verify actual device performance in their specific applications.

\*RoHS COMPLIANT

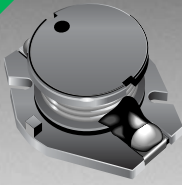

**BOURNS®**

### Features

- Available in E6 series
- Low profile of only 6.6 mm
- Inductance as low as 1  $\mu$ H
- RoHS compliant\*

### Applications

- Input/output of DC/DC converters
- Power supplies for:
  - Portable communications equipment
  - Camcorders
  - LCD TVs
  - Car radios

## SDR1806 Series - SMD Power Inductors

### Electrical Specifications

Bourns Part No.	Inductance 100 kHz		Q Ref.	Test Frequency (MHz)	SRF Typ. (MHz)	RDC Max. ( $m\Omega$ )	I rms Max. (A)	I sat Typ. (A)
	( $\mu$ H)	Tol. %						
SDR1806-1R0ML	1	$\pm 20$	21	7.96	100.0	4.0	10.0	30.00
SDR1806-2R2ML	2.2	$\pm 20$	22	7.96	55.0	6.8	9.00	22.00
SDR1806-3R3ML	3.3	$\pm 20$	22	7.96	40.0	9.8	7.60	17.00
SDR1806-5R6ML	5.6	$\pm 20$	23	7.96	30.0	15.0	6.40	12.80
SDR1806-8R2ML	8.2	$\pm 20$	22	7.96	27.0	20.0	7.00	9.40
SDR1806-100ML	10.0	$\pm 20$	22	2.52	25.0	25.0	5.30	10.00
SDR1806-150ML	15.0	$\pm 20$	20	2.52	17.0	35.0	4.30	8.00
SDR1806-220ML	22.0	$\pm 20$	22	2.52	13.0	45.0	3.60	6.70
SDR1806-330ML	33.0	$\pm 20$	24	2.52	11.0	68.0	3.00	5.40
SDR1806-470ML	47.0	$\pm 20$	22	2.52	9.0	95.0	2.50	4.60
SDR1806-680ML	68.0	$\pm 20$	22	2.52	8.0	130.0	2.10	3.80
SDR1806-101KL	100.0	$\pm 10$	25	0.796	7.0	190.0	1.70	3.20
SDR1806-151KL	150.0	$\pm 10$	23	0.796	5.0	270.0	1.40	2.60
SDR1806-221KL	220.0	$\pm 10$	20	0.796	4.5	420.0	1.10	2.20
SDR1806-331KL	330.0	$\pm 10$	18	0.796	3.5	580.0	1.00	1.80
SDR1806-471KL	470.0	$\pm 10$	15	0.796	3.0	820.0	0.80	1.50
SDR1806-681KL	680.0	$\pm 10$	12	0.796	2.5	1200.0	0.70	1.20
SDR1806-102KL	1000.0	$\pm 10$	10	0.252	2.0	1800.0	0.50	1.00

### Electrical Schematic

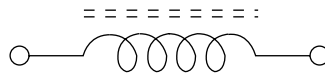

### General Specifications

Test Voltage.....0.1 V  
 Reflow soldering.....250 °C; 10 sec max.  
 (In compliance with JEDEC, J-STD-020C, Table 4-2)  
 Operating Temperature...-40 °C to +125 °C  
 (Temperature rise included)  
 Storage Temperature...-40 °C to +125 °C  
 Resistance to Soldering Heat  
 .....250 °C, 10 sec. max.

### Materials

Core.....Ferrite DR  
 Wire.....Enameled copper  
 Base.....LCP E4008  
 Terminal.....Cu/Sn  
 Rated Current  
 .....Ind. drop 10 % typ. at Isat  
 Temperature Rise .....40 °C max.  
 at rated Irms  
 Packaging.....250 pcs. per reel

### Product Dimensions

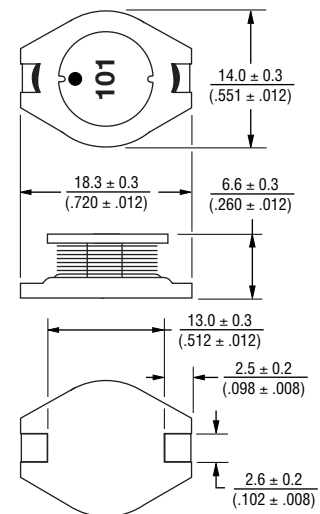

● = START OF WINDING

### Recommended Layout

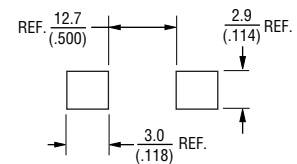

DIMENSIONS:  $\frac{\text{MM}}{\text{(INCHES)}}$

\*RoHS Directive 2002/95/EC Jan 27, 2003 including Annex  
 Specifications are subject to change without notice.  
 Customers should verify actual device performance in their specific applications.

# SDR1806 Series - SMD Power Inductor

**BOURNS®**

## Soldering Profile

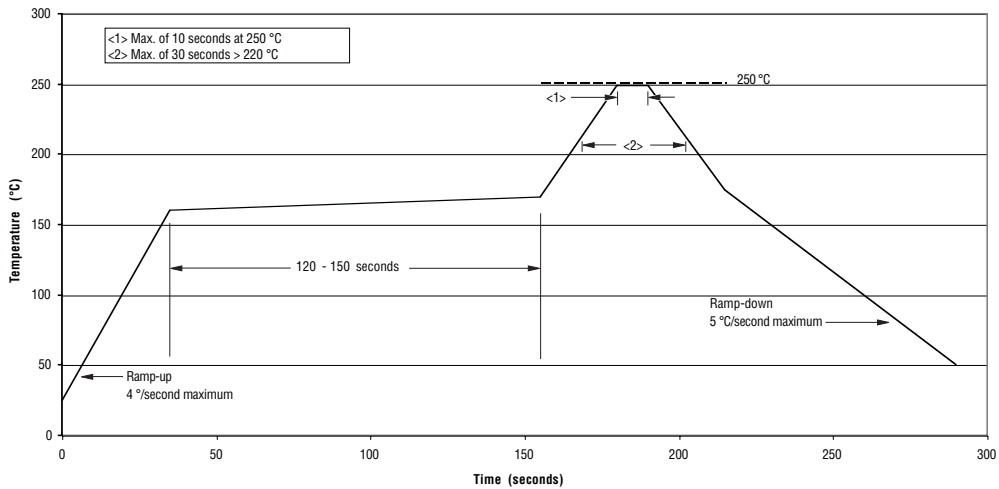

## Packaging Specifications

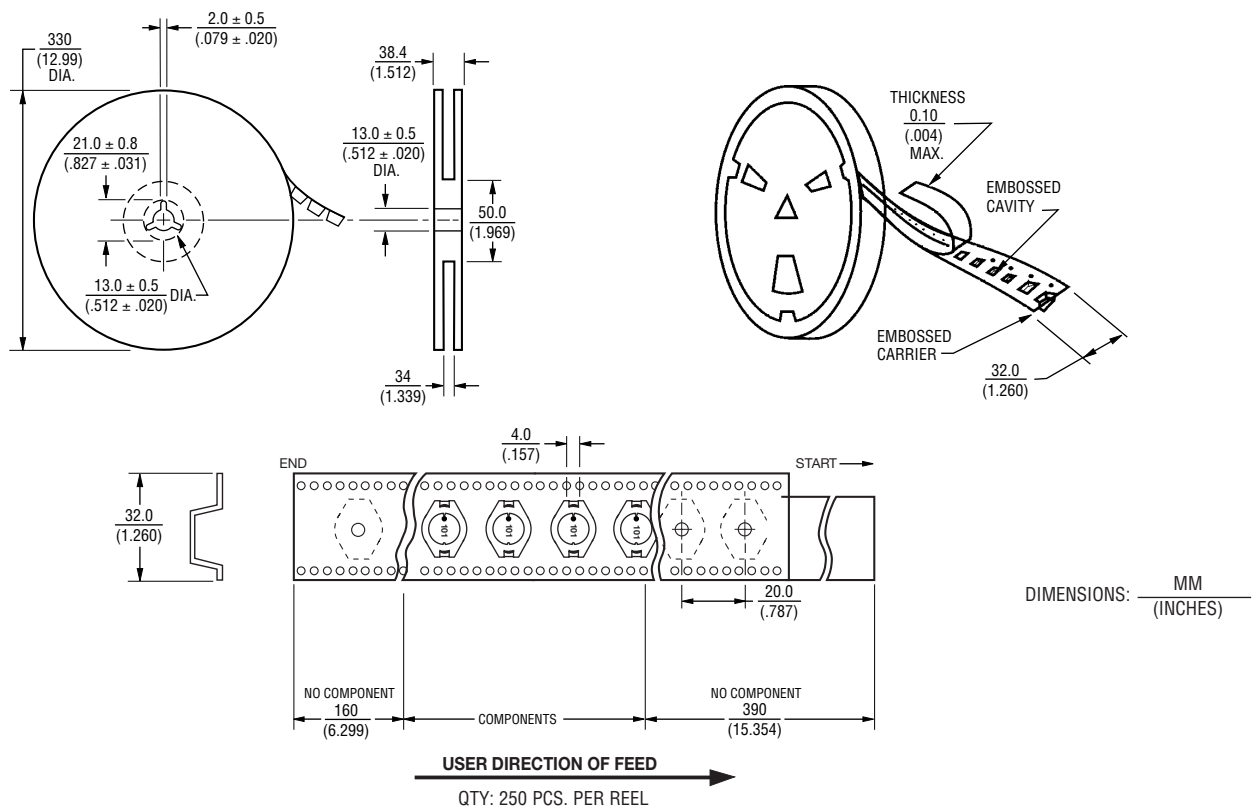

REV. 09/10

Specifications are subject to change without notice.

Customers should verify actual device performance in their specific applications.



## Features

- Available in E12 series
- Low height of only 7.0 mm
- Inductance as low as 0.78  $\mu$ H
- High current up to 16 amps
- RoHS compliant\*

## Applications

- Input/output of DC/DC converters
- Power supplies for:
  - Portable communications equipment
  - Camcorders
  - LCD TVs
  - Car radios

# SDR2207 Series - SMD Power Inductors

## Electrical Specifications

Bourns Part No.	Inductance 100 KHz		Q Ref.	Test Frequency (MHz)	SRF Min. (MHz)	RDC Max. ( $m\Omega$ )	I rms Max. (A)	I sat Typ. (A)
	( $\mu$ H)	Tol. %						
SDR2207-R78ML	0.78	$\pm 20$	30	5	104.0	2.6	15.0	30.0
SDR2207-R80ML	0.8	$\pm 20$	30	5	102.0	2.8	16.0	35.0
SDR2207-1R2ML	1.2	$\pm 20$	30	3	70.0	3.8	15.0	30.0
SDR2207-1R5ML	1.5	$\pm 20$	30	3	60.0	5.0	15.0	25.0
SDR2207-1R8ML	1.8	$\pm 20$	31	3	51.0	4.5	13.0	25.0
SDR2207-2R2ML	2.2	$\pm 20$	35	3	51.0	7.5	13.0	20.0
SDR2207-2R7ML	2.7	$\pm 20$	38	3	51.0	7.0	10.0	20.0
SDR2207-3R3ML	3.3	$\pm 20$	38	3	39.0	7.8	9.0	17.0
SDR2207-3R9ML	3.9	$\pm 20$	38	3	36.0	12.0	9.0	15.0
SDR2207-4R7ML	4.7	$\pm 20$	38	3	33.0	8.8	8.5	15.0
SDR2207-5R6ML	5.6	$\pm 20$	50	3	30.0	13.4	7.8	14.0
SDR2207-6R0ML	6.0	$\pm 20$	43	3	28.0	17.0	7.5	12.0
SDR2207-6R8ML	6.8	$\pm 20$	38	3	27.0	14.2	7.5	12.0
SDR2207-7R8ML	7.8	$\pm 20$	36	3	26.0	20.0	7.5	11.0
SDR2207-8R2ML	8.2	$\pm 20$	35	3	25.0	15.5	7.0	11.0
SDR2207-100ML	10	$\pm 20$	53	5	20.0	17.2	6.5	10.0
SDR2207-120YL	12	$\pm 15$	50	5	19.0	23.6	5.5	9.5
SDR2207-150YL	15	$\pm 15$	38	5	16.0	28.8	5.0	9.0
SDR2207-180YL	18	$\pm 15$	46	5	15.0	33.0	4.6	8.0
SDR2207-220YL	22	$\pm 15$	27	3	14.0	39.4	4.0	6.5
SDR2207-270YL	27	$\pm 15$	22	3	12.0	43.5	3.8	6.0
SDR2207-330YL	33	$\pm 15$	27	3	11.0	58.4	3.4	5.5
SDR2207-390KL	39	$\pm 10$	18	3	10.0	65.0	3.2	5.2
SDR2207-470KL	47	$\pm 10$	27	3	9.0	91.2	2.8	5.0
SDR2207-560KL	56	$\pm 10$	25	2	8.3	96.5	2.6	4.5
SDR2207-680KL	68	$\pm 10$	18	2	7.9	112.0	2.4	4.0
SDR2207-820KL	82	$\pm 10$	28	2	6.5	144.0	2.3	3.5
SDR2207-101KL	100	$\pm 10$	18	2	6.2	168.0	2.2	3.0
SDR2207-121KL	120	$\pm 10$	20	2	6.0	230.0	1.6	3.0
SDR2207-151KL	150	$\pm 10$	22	2	5.8	250.0	1.5	2.6
SDR2207-181KL	180	$\pm 10$	20	2	5.7	300.0	1.3	2.5
SDR2207-221KL	220	$\pm 10$	19	2	5.5	380.0	1.2	2.4
SDR2207-271KL	270	$\pm 10$	17	2	5.3	470.0	1.1	2.2
SDR2207-331KL	330	$\pm 10$	20	1	5.1	560.0	1.0	1.9
SDR2207-391KL	390	$\pm 10$	17	1	4.9	680.0	0.9	1.7
SDR2207-471KL	470	$\pm 10$	19	1	4.7	850.0	0.8	1.4
SDR2207-561KL	560	$\pm 10$	18	1	4.5	1000	0.8	1.3
SDR2207-681KL	680	$\pm 10$	16	1	4.2	1100	0.7	1.2
SDR2207-821KL	820	$\pm 10$	16	1	3.9	1400	0.6	1.1
SDR2207-102KL	1000	$\pm 10$	15	1	3.5	1800	0.6	1.0

## General Specifications

Test Voltage .....0.1 V  
 Reflow soldering .....250 °C; 10 sec max.  
 (In compliance with JEDEC, J-STD-020C, Table 4-2)  
 Operating Temperature  
 .....-40 °C to +125 °C  
 (Temperature rise included)  
 Storage Temperature  
 .....-40 °C to +125 °C  
 Resistance to Soldering Heat  
 .....250 °C, 10 sec. max.

## Materials

Core.....Ferrite DR  
 Wire.....Enameled copper  
 Terminal.....Cu/Ag/Sn  
 Base.....Phenolic T375J  
 Adhesive .....Epoxy resin  
 Rated Current  
 .....Ind. drop 10 % typ. at Isat  
 Temperature Rise  
 .....40 °C max. at rated I rms  
 Packaging .....250 pcs. per reel

## Product Dimensions

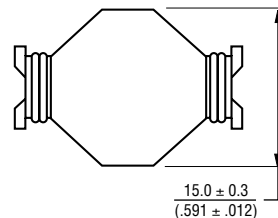
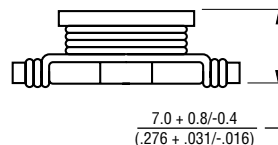
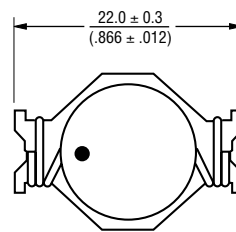

● = START OF WINDING

DIMENSIONS:  $\frac{\text{MM}}{\text{(INCHES)}}$

## Electrical Schematic

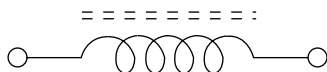

## Recommended Layout

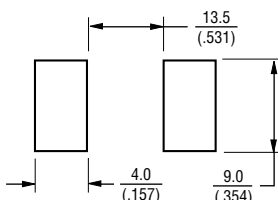

\*RoHS Directive 2002/95/EC Jan 27, 2003 including Annex  
 Specifications are subject to change without notice.  
 Customers should verify actual device performance in their specific applications.

# SDR2207 Series - SMD Power Inductors

**BOURNS®**

## Soldering Profile

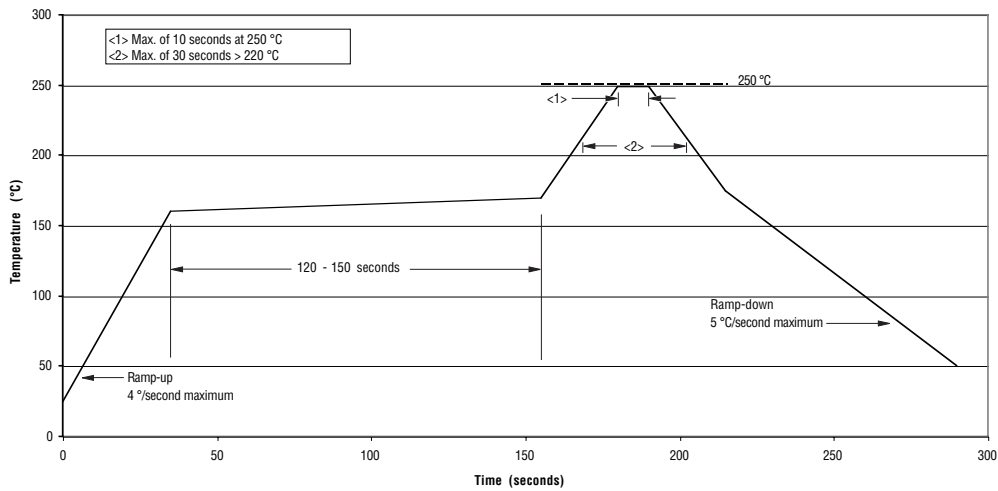

## Packaging Specifications

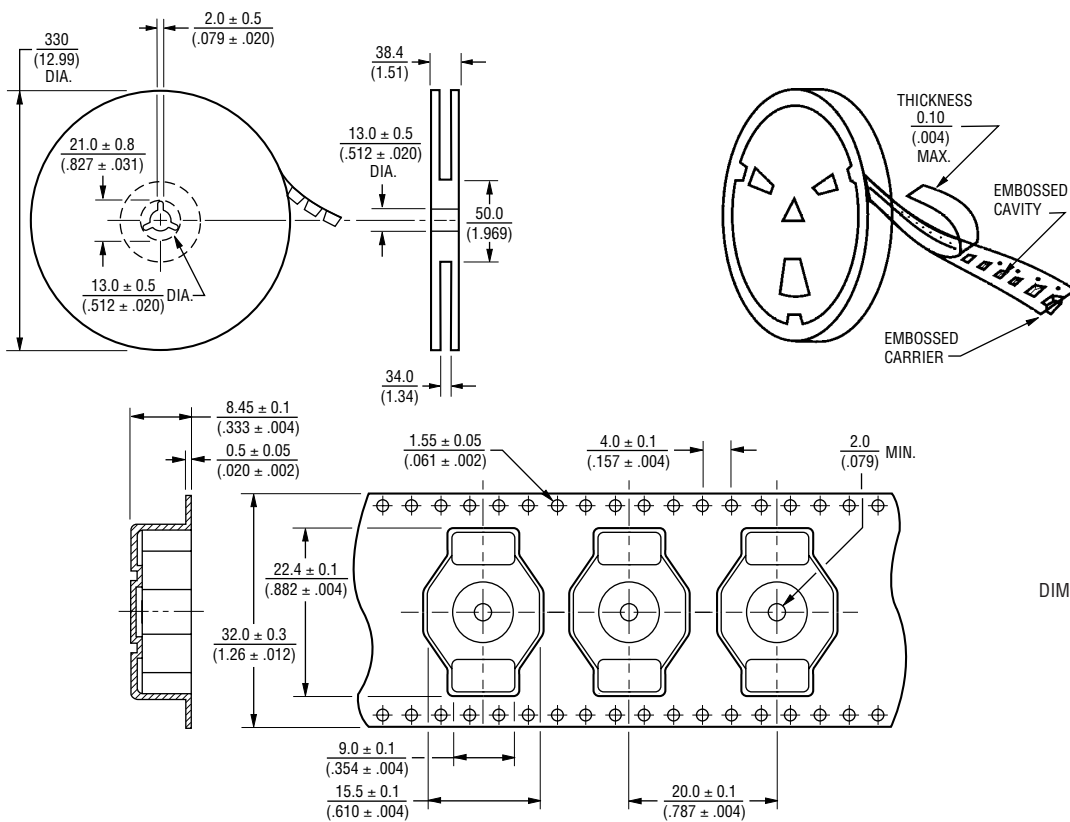

DIMENSIONS:  $\frac{\text{MM}}{\text{(INCHES)}}$

QTY: 250 PCS. PER REEL

REV. 09/10

Specifications are subject to change without notice.  
Customers should verify actual device performance in their specific applications.

RoHS COMPLIANT

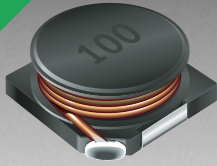

**BOURNS®**

### Features

- Available in E6 values
- Range from 1.0  $\mu$ H to 1000  $\mu$ H
- Lead free
- RoHS compliant\*

### Applications

- Input/output of DC/DC converters
- Power supplies for:
  - Portable communication equipment
  - Camcorders
  - LCD TVs
  - Car radios

## SDR7030 Series - SMD Power Inductors

### Electrical Specifications

Bourns Part No.	Inductance 100 kHz		Q Typ.	Test Frequency (MHz)	SRF Min. (MHz)	RDC Max. ( $\Omega$ )	I rms Max. (A)	I sat Typ. (A)
	( $\mu$ H)	Tol. %						
SDR7030-1R0M	1.0	$\pm 20$	18	7.96	113	0.022	3.00	4.30
SDR7030-1R5M	1.5	$\pm 20$	17	7.96	100	0.027	2.75	3.60
SDR7030-2R2M	2.2	$\pm 20$	17	7.96	80	0.030	2.60	3.20
SDR7030-3R5M	3.5	$\pm 20$	17	7.96	59	0.038	2.20	2.60
SDR7030-4R7M	4.7	$\pm 20$	14	7.96	43	0.048	1.85	2.25
SDR7030-6R2M	6.2	$\pm 20$	17	7.96	41	0.058	1.65	2.00
SDR7030-100M	10.0	$\pm 20$	16	2.52	35	0.075	1.50	1.60
SDR7030-150M	15.0	$\pm 20$	14	2.52	33	0.115	1.20	1.30
SDR7030-220M	22.0	$\pm 20$	14	2.52	32	0.160	1.02	1.10
SDR7030-330M	33.0	$\pm 20$	13	2.52	24	0.230	0.85	0.90
SDR7030-470K	47.0	$\pm 10$	12	2.52	18	0.340	0.70	0.78
SDR7030-680K	68.0	$\pm 10$	12	2.52	16	0.480	0.58	0.64
SDR7030-101K	100.0	$\pm 10$	18	0.796	15	0.720	0.46	0.52
SDR7030-151K	150.0	$\pm 10$	18	0.796	12	0.920	0.40	0.42
SDR7030-221K	220.0	$\pm 10$	23	0.796	9	1.600	0.32	0.34
SDR7030-331K	330.0	$\pm 10$	24	0.796	7	2.200	0.26	0.28
SDR7030-471K	470.0	$\pm 10$	30	0.796	6	2.800	0.22	0.23
SDR7030-681K	680.0	$\pm 10$	28	0.796	5	4.350	0.18	0.18
SDR7030-102K	1000.0	$\pm 10$	66	0.252	4	6.200	0.15	0.15

### General Specifications

Test Voltage.....0.1 V  
 Reflow Soldering ...230 °C, 50 sec. max.  
 Operating Temperature -40 °C to +125 °C  
 (Temperature rise included)  
 Storage Temperature...-40 °C to +125 °C  
 Resistance to Soldering Heat  
 .....260 °C for 10 sec.

### Materials

Core .....Ferrite DR  
 Wire .....Enameled copper wire 130  
 Terminal.....Cu/Ni/Sn  
 Rated Current  
 .....Ind. drop 10 % typ. at Isat  
 Temperature Rise .....30 °C max.  
 at rated Irms  
 Packaging .....1500 pcs. per reel

### Product Dimensions

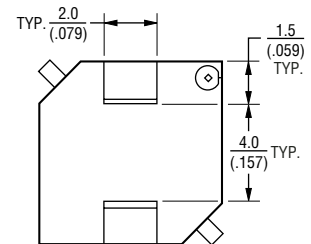
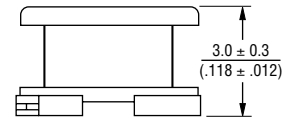
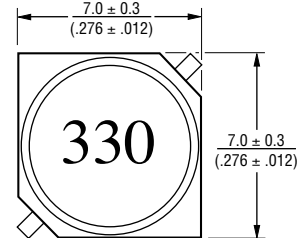

DIMENSIONS:  $\frac{\text{MM}}{\text{(INCHES)}}$

### Electrical Schematic

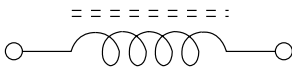

### Recommended Layout

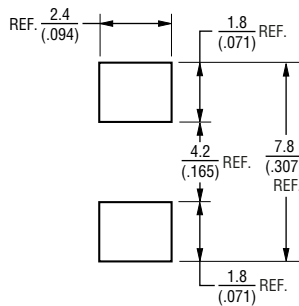

\*RoHS Directive 2002/95/EC Jan 27 2003 including Annex  
 Specifications are subject to change without notice.  
 Customers should verify actual device performance in their specific applications.



# SDR7030 Series - SMD Power Inductors

**BOURNS®**

## Packaging Specifications

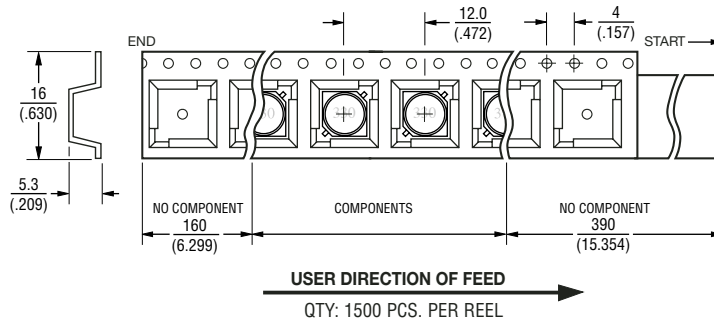
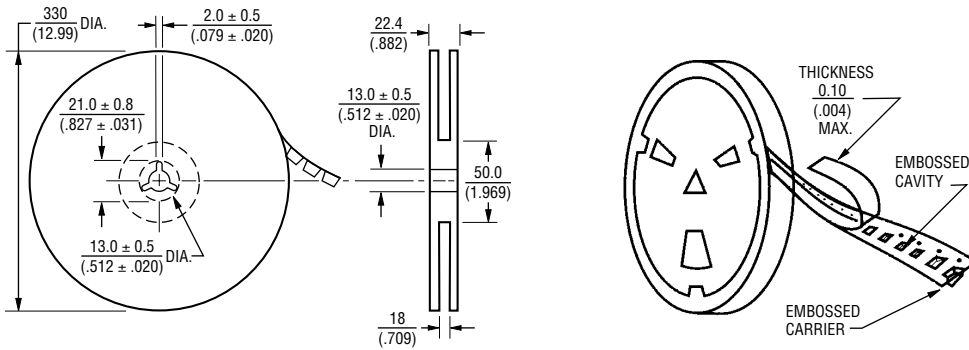

DIMENSIONS:  $\frac{\text{MM}}{\text{(INCHES)}}$

REV. 05/05

Specifications are subject to change without notice.  
Customers should verify actual device performance in their specific applications.

\*RoHS COMPLIANT

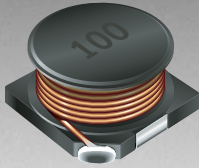

**BOURNS®**

### Features

- Available in E6 values
- Current rating to 3.8 amps
- Lead free
- RoHS compliant\*

### Applications

- Input/output of DC/DC converters
- Power supplies for:
  - Portable communication equipment
  - Camcorders
  - LCD TVs
  - Car radios

## SDR7045 Series - SMD Power Inductors

### Electrical Specifications

Bourns Part No.	Inductance 100 kHz		Q Typ.	Test Frequency (MHz)	SRF Min. (MHz)	RDC Max. (Ω)	I rms Max. (A)	I sat Typ. (A)
	(μH)	Tol. %						
SDR7045-1R2M	1.2	± 20	25	7.96	90	0.022	3.80	5.00
SDR7045-1R5M	1.5	± 20	26	7.96	109	0.027	3.50	4.50
SDR7045-2R2M	2.2	± 20	24	7.96	79	0.032	3.30	4.00
SDR7045-3R3M	3.3	± 20	23	7.96	47	0.036	2.80	3.70
SDR7045-4R7M	4.7	± 20	23	7.96	38	0.042	2.60	3.40
SDR7045-6R8M	6.8	± 20	22	7.96	35	0.054	2.25	2.70
SDR7045-100M	10.0	± 20	28	2.52	23	0.070	2.00	2.30
SDR7045-150M	15.0	± 20	24	2.52	19	0.086	1.60	1.90
SDR7045-220M	22.0	± 20	26	2.52	18	0.125	1.40	1.62
SDR7045-330M	33.0	± 20	20	2.52	18	0.150	1.22	1.32
SDR7045-470K	47.0	± 10	21	2.52	11	0.230	1.00	1.10
SDR7045-680K	68.0	± 10	17	2.52	11	0.280	0.90	0.92
SDR7045-101K	100.0	± 10	17	0.796	10	0.430	0.75	0.72
SDR7045-151K	150.0	± 10	17	0.796	8	0.580	0.62	0.58
SDR7045-221K	220.0	± 10	22	0.796	6	0.930	0.50	0.48
SDR7045-331K	330.0	± 10	20	0.796	6	1.240	0.42	0.40
SDR7045-471K	470.0	± 10	20	0.796	4	1.850	0.34	0.30
SDR7045-681K	680.0	± 10	18	0.796	4	2.400	0.30	0.26
SDR7045-102K	1000.0	± 10	48	0.252	3	4.000	0.22	0.20

### General Specifications

Test Voltage.....0.1 V  
 Reflow Soldering ...230 °C, 50 sec. max.  
 Operating Temperature -40 °C to +125 °C  
 (Temperature rise included)  
 Storage Temperature...-40 °C to +125 °C  
 Resistance to Soldering Heat  
 .....260 °C for 10 sec.

### Materials

Core .....Ferrite DR  
 Wire .....Enameled copper wire 130  
 Terminal.....Cu/Ni/Sn  
 Rated Current  
 .....Ind. drop 10 % typ. at Isat  
 Temperature Rise .....40 °C max.  
 at rated I rms  
 Packaging .....1000 pcs. per reel

### Product Dimensions

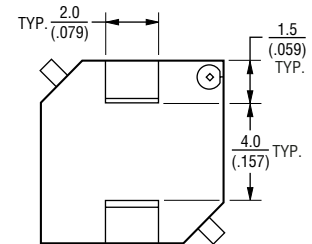
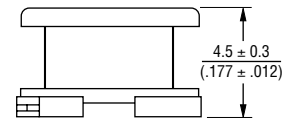
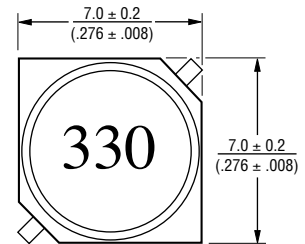

DIMENSIONS:  $\frac{\text{MM}}{\text{(INCHES)}}$

### Electrical Schematic

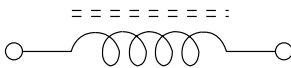

### Recommended Layout

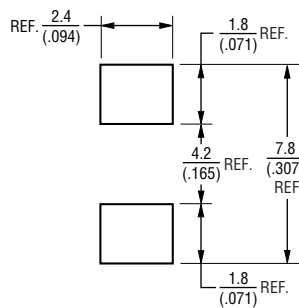

\*RoHS Directive 2002/95/EC Jan 27 2003 including Annex  
 Specifications are subject to change without notice.  
 Customers should verify actual device performance in their specific applications.

# SDR7045 Series - SMD Power Inductors

**BOURNS®**

## Packaging Specifications

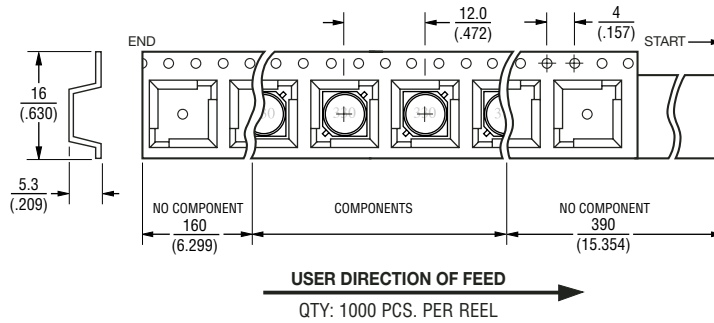
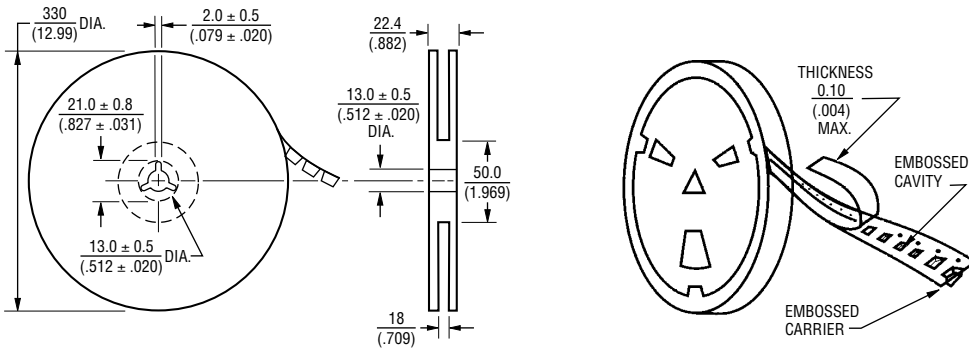

DIMENSIONS:  $\frac{\text{MM}}{\text{(INCHES)}}$

REV. 05/05

Specifications are subject to change without notice.  
Customers should verify actual device performance in their specific applications.

RoHS COMPLIANT

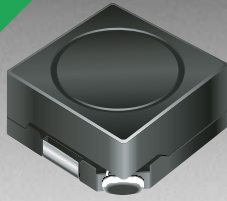

**BOURNS®**

## Features

- Available in E6 series
- Low unit height of 3.3 mm
- High current
- RoHS compliant\*

## Applications

- Input/output of DC/DC converters
- Power supplies for:
  - Portable communication equipment
  - Camcorders
  - LCD TVs
  - Car radios

# SRR0603 Series - Shielded Power Inductors

### Electrical Specifications

Bourns Part No.	Inductance 1kHz		Q Ref.	Test Frequency (MHz)	SRF Min. (MHz)	RDC (Ω)	I rms Max. (A)	I sat Typ. (A)
	(μH)	Tol. %						
SRR0603-1R5ML	1.5	± 20	20	7.96	95.0	0.032	2.20	3.50
SRR0603-2R5ML	2.5	± 20	19	7.96	90.0	0.040	2.00	2.95
SRR0603-3R3ML	3.3	± 20	16	7.96	85.0	0.055	1.80	2.60
SRR0603-4R7ML	4.7	± 20	13	7.96	45.0	0.070	1.60	2.20
SRR0603-6R8ML	6.8	± 20	13	7.96	32.0	0.100	1.20	1.75
SRR0603-100ML	10	± 20	16	2.52	25.0	0.12	1.10	1.50
SRR0603-150ML	15	± 20	16	2.52	25.0	0.18	0.90	1.20
SRR0603-220ML	22	± 15	16	2.52	20.0	0.27	0.70	1.05
SRR0603-330KL	33	± 10	15	2.52	16.0	0.43	0.60	0.83
SRR0603-470KL	47	± 10	13	2.52	13.0	0.55	0.50	0.73
SRR0603-680KL	68	± 10	11	2.52	10.0	0.90	0.40	0.53
SRR0603-101KL	100	± 10	22	0.796	9.0	1.50	0.30	0.44
SRR0603-151KL	150	± 10	22	0.796	8.0	1.90	0.25	0.39
SRR0603-221KL	220	± 10	20	0.796	5.0	2.70	0.20	0.31
SRR0603-331KL	330	± 10	18	0.796	4.5	4.20	0.18	0.24
SRR0603-471KL	470	± 10	17	0.796	4.0	6.70	0.15	0.19
SRR0603-681KL	680	± 10	13	0.796	3.5	10.50	0.12	0.15
SRR0603-102KL	1000	± 10	20	0.252	3.0	14.00	0.10	0.13

### Electrical Schematic

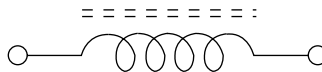

### General Specifications

Test Voltage ..... 1 Volt  
 Reflow Soldering ..... 230 °C; 50 sec max.  
 Operating Temperature .. -40 °C to +125 °C  
 (Temperature rise included)  
 Storage Temperature .. -40 °C to +125 °C  
 Resistance to Soldering Heat  
 ..... 260 °C for 5 sec.

### Materials

Core Material ..... Ferrite DR & RI  
 Wire ..... Enamelled Copper  
 Base ..... LCP E4008  
 Terminal ..... Cu/Ni/Sn  
 Rated Current ... Ind. drop 10 % typ at I sat  
 Temperature Rise .40 °C max at rated I rms  
 Packaging ..... 1000 pcs. per reel

### Product Dimensions

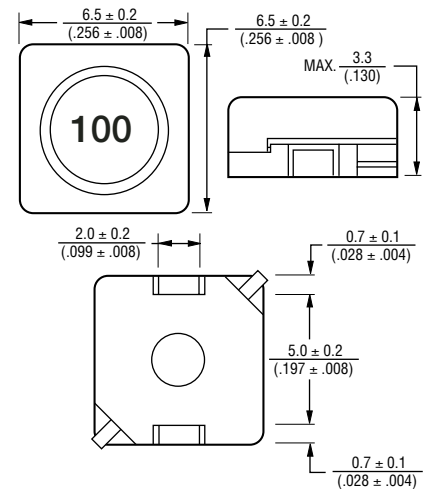

### Recommended Layout

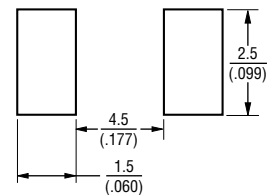

DIMENSIONS:  $\frac{\text{MM}}{\text{(INCHES)}}$

\*RoHS Directive 2002/95/EC Jan 27 2003 including Annex  
 Specifications are subject to change without notice.  
 Customers should verify actual device performance in their specific applications.

# SRR0603 Series - Shielded Power Inductors

**BOURNS®**

## Packaging Specifications

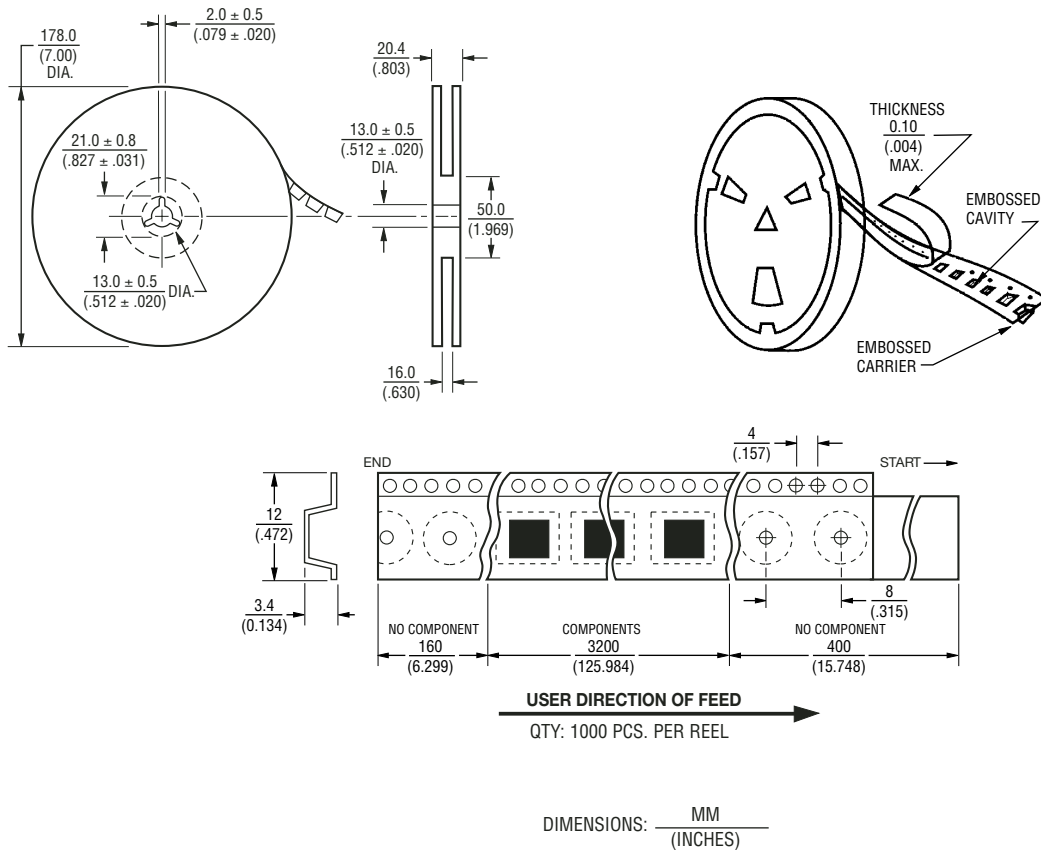

REV. 06/07

Specifications are subject to change without notice.  
Customers should verify actual device performance in their specific applications.

\*RoHS COMPLIANT

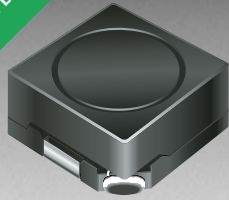

**BOURNS®**

## Features

- Available in E6 series
- Low unit height of 4.8 mm
- High current
- RoHS compliant\*

## Applications

- Input/output of DC/DC converters
- Power supplies for:
  - Portable communication equipment
  - Camcorders
  - LCD TVs
  - Car radios

# SRR0604 Series - Shielded Power Inductors

### Electrical Specifications

Bourns Part No.	Inductance 1kHz		Q Ref.	Test Frequency (MHz)	SRF Min. (MHz)	RDC (Ω)	I rms Max. (A)	I sat Typ. (A)
	(μH)	Tol. %						
SRR0604-1R5ML	1.5	± 20	23	7.96	110.0	0.028	2.80	3.95
SRR0604-2R5ML	2.5	± 20	21	7.96	100.0	0.035	2.50	3.50
SRR0604-3R3ML	3.3	± 20	21	7.96	90.0	0.050	2.30	2.90
SRR0604-4R7ML	4.7	± 20	10	7.96	50.0	0.060	2.00	2.55
SRR0604-6R8ML	6.8	± 20	20	7.96	37.0	0.070	1.60	2.05
SRR0604-100ML	10	± 20	18	2.52	30.0	0.12	1.30	1.80
SRR0604-150ML	15	± 20	18	2.52	30.0	0.13	1.10	1.45
SRR0604-220ML	22	± 20	16	2.52	25.0	0.19	0.90	1.20
SRR0604-330KL	33	± 10	16	2.52	21.0	0.25	0.70	0.95
SRR0604-470KL	47	± 10	15	2.52	18.0	0.35	0.60	0.80
SRR0604-680KL	68	± 10	15	2.52	15.0	0.52	0.50	0.68
SRR0604-101KL	100	± 10	23	0.796	13.0	0.65	0.40	0.57
SRR0604-151KL	150	± 10	21	0.796	12.0	1.00	0.30	0.47
SRR0604-221KL	220	± 10	20	0.796	10.0	1.70	0.25	0.32
SRR0604-331KL	330	± 10	18	0.796	7.0	2.10	0.20	0.28
SRR0604-471KL	470	± 10	18	0.796	6.5	3.30	0.18	0.22
SRR0604-681KL	680	± 10	16	0.796	6.0	4.80	0.15	0.19
SRR0604-102KL	1000	± 10	15	0.252	5.5	6.10	0.12	0.15

### Electrical Schematic

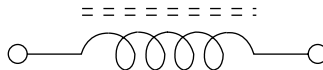

### General Specifications

Test Voltage.....1 Volt  
 Reflow Soldering.....230 °C; 50 sec max.  
 Operating Temperature ..-40 °C to +125 °C  
 (Temperature rise included)  
 Storage Temperature...-40 °C to +125 °C  
 Resistance to Soldering Heat  
 .....260 °C for 5 sec.

### Materials

Core Material.....Ferrite DR & RI  
 Wire .....Enamelled Copper  
 Base .....LCP E4008  
 Terminal.....Cu/Ni/Sn  
 Rated Current ..Ind. drop 10 % typ at I sat  
 Temperature Rise ..40 °C max at rated I rms  
 Packaging.....1000 pcs. per reel

### Product Dimensions

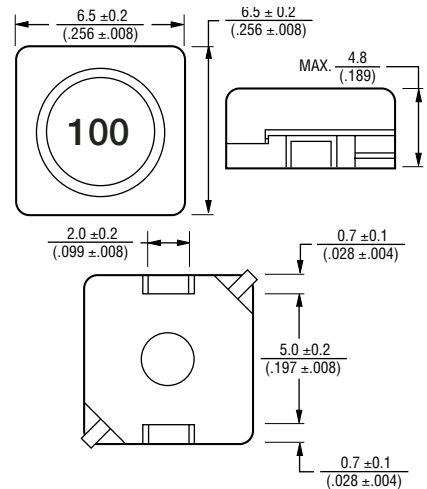

### Recommended Layout

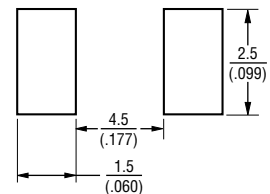

DIMENSIONS:  $\frac{\text{MM}}{\text{(INCHES)}}$

\*RoHS Directive 2002/95/EC Jan 27 2003 including Annex  
 Specifications are subject to change without notice.  
 Customers should verify actual device performance in their specific applications.

# SRR0604 Series - Shielded Power Inductors

**BOURNS®**

## Packaging Specifications

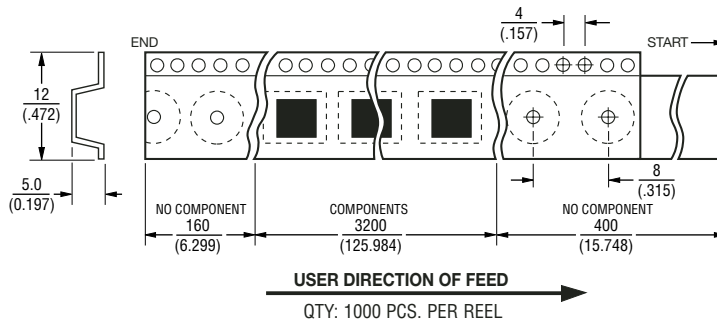
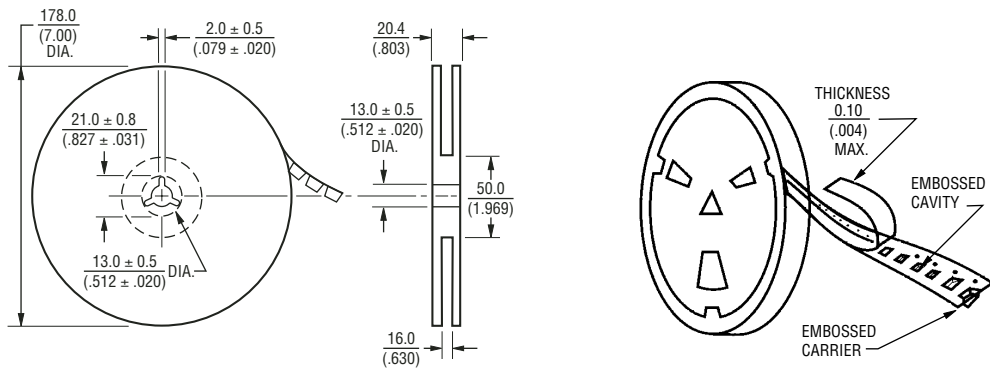

DIMENSIONS:  $\frac{\text{MM}}{\text{(INCHES)}}$

REV. 05/07

Specifications are subject to change without notice.  
Customers should verify actual device performance in their specific applications.

\*RoHS COMPLIANT

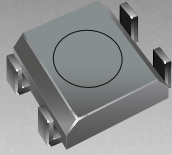

**BOURNS®**

## Features

- Available in E6 series
- Low unit height of 1.8 mm
- High current
- RoHS compliant\*

## Applications

- Input/output of DC/DC converters
- Power supplies for:
  - Portable communication equipment
  - Camcorders
  - LCD TVs
  - Car radios

# SRR0618 Series - Shielded Power Inductors

### Electrical Specifications

Bourns Part No.	Inductance 100kHz		Q Ref.	Test Frequency (kHz)	SRF Nom. (MHz)	RDC Max. (Ω)	I rms Typ. (A)	I sat Typ. (A)
	(μH)	Tol. %						
SRR0618-2R2ML	2.2	± 20	30	100	95	0.05	1.70	2.10
SRR0618-3R3ML	3.3	± 20	30	100	70	0.07	1.40	1.75
SRR0618-4R7ML	4.7	± 20	30	100	65	0.10	1.05	1.45
SRR0618-6R8ML	6.8	± 20	30	100	50	0.15	0.95	1.18
SRR0618-100ML	10.0	± 20	30	100	45	0.22	0.82	0.98
SRR0618-150ML	15.0	± 20	30	100	35	0.31	0.60	0.76
SRR0618-220ML	22.0	± 20	30	100	25	0.46	0.47	0.60
SRR0618-330ML	33.0	± 20	30	100	22	0.68	0.43	0.53
SRR0618-470ML	47.0	± 20	30	100	20	1.10	0.36	0.44
SRR0618-680ML	68.0	± 20	30	100	15	1.50	0.30	0.37
SRR0618-101ML	100.0	± 20	30	100	13	2.30	0.23	0.27

### General Specifications

Test Voltage.....0.1 Volt  
 Reflow Soldering.....230 °C, 50 sec max.  
 Operating Temperature...-40 °C to +125 °C  
 (Temperature rise included)  
 Storage Temperature...-40 °C to +125 °C  
 Resistance to Soldering Heat  
 .....260 °C for 10 sec.

### Materials

Core Material.....Ferrite DR  
 Wire .....Enamelled Copper  
 Base .....Ferrite Core  
 Terminal.....Cu/Ni/Sn  
 Rated Current...Ind. drop 50 % typ at I sat  
 Temperature Rise  
 .....40 °C max at rated I rms  
 Packaging.....900 pcs. per reel

### Recommended Layout

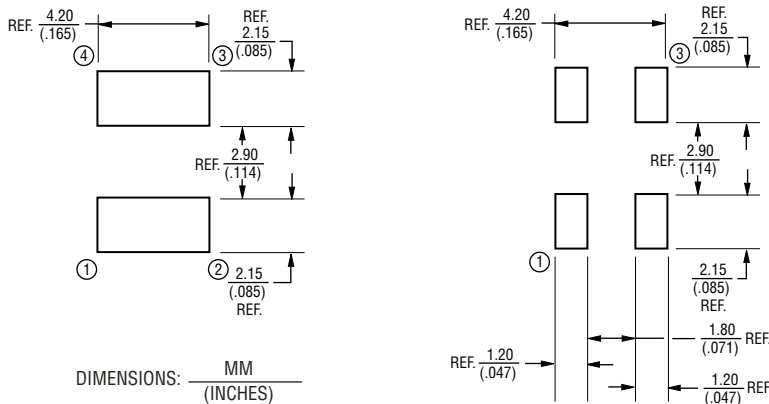

### Product Dimensions

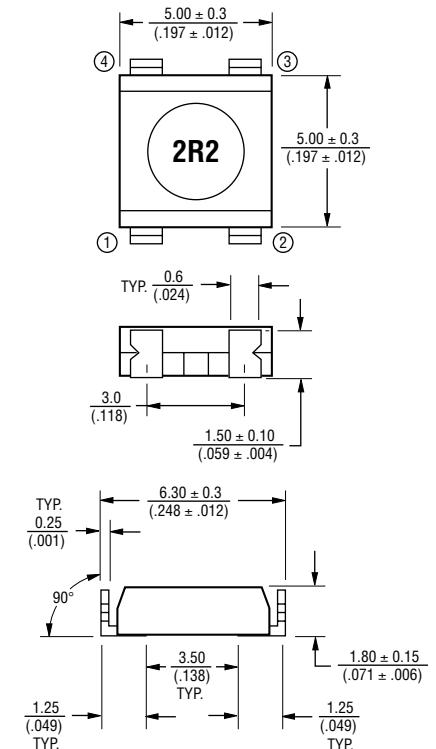

### Electrical Schematic

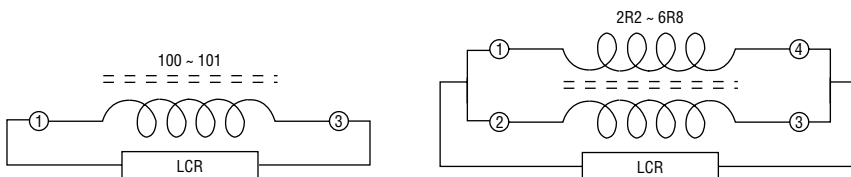

\*RoHS Directive 2002/95/EC Jan 27 2003 including Annex  
 Specifications are subject to change without notice.  
 Customers should verify actual device performance in their specific applications.



# SRR0618 Series - Shielded Power Inductors

**BOURNS®**

## Packaging Specifications

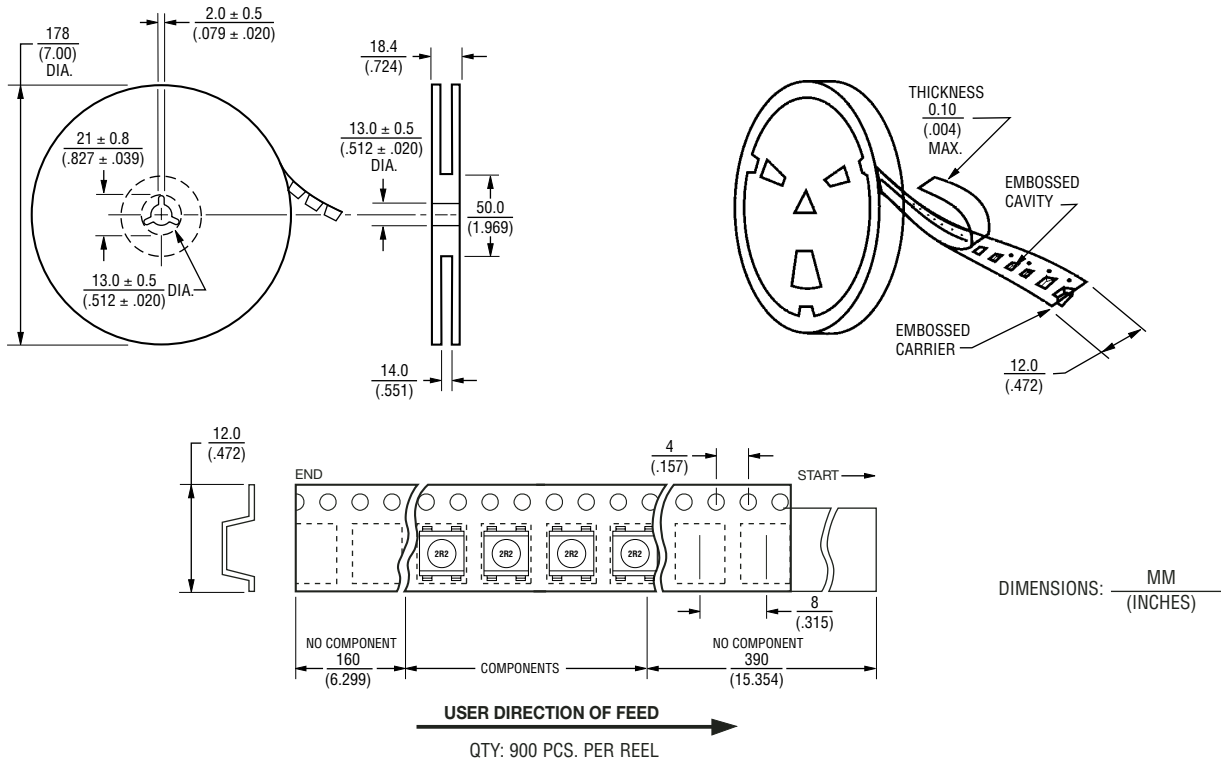

REV. 03/07

Specifications are subject to change without notice.  
Customers should verify actual device performance in their specific applications.



## Features

- Available in E12 series
- Low profile - 3.8 mm unit height
- High current
- Lead free
- RoHS compliant\*

## Applications

- Input/output of DC/DC converters
- Power supplies for:
  - Portable communication equipment
  - Camcorders
  - LCD TVs
  - Car radios

# SRR0804 Series - Shielded Power Inductors

## Electrical Specifications

Bourns Part No.	Inductance 1kHz		Q Ref.	Test Frequency (MHz)	SRF Min. (MHz)	RDC (Ω)	I rms Max. (A)	I sat Typ. (A)
	(μH)	Tol. %						
SRR0804-5R0M	5.0	± 20	20	7.96M	45.0	0.08	1.70	2.80
SRR0804-7R5M	7.5	± 20	20	7.96M	40.0	0.10	1.40	2.60
SRR0804-100M	10	± 20	38	2.52M	32.0	0.12	1.20	2.20
SRR0804-120M	12	± 20	38	2.52M	28.0	0.15	1.10	1.90
SRR0804-150M	15	± 20	38	2.52M	25.0	0.17	1.00	1.60
SRR0804-180Y	18	± 15	35	2.52M	23.0	0.19	0.90	1.50
SRR0804-220Y	22	± 15	30	2.52M	22.0	0.25	0.80	1.30
SRR0804-270Y	27	± 15	28	2.52M	18.0	0.27	0.70	1.30
SRR0804-330Y	33	± 15	26	2.52M	17.0	0.30	0.65	1.10
SRR0804-390Y	39	± 15	26	2.52M	16.0	0.38	0.60	1.00
SRR0804-470K	47	± 10	24	2.52M	14.0	0.46	0.55	0.95
SRR0804-560K	56	± 10	24	2.52M	12.0	0.60	0.50	0.85
SRR0804-680K	68	± 10	22	2.52M	11.0	0.70	0.45	0.80
SRR0804-820K	82	± 10	20	2.52M	10.0	0.80	0.40	0.73
SRR0804-101K	100	± 10	50	0.796M	9.0	0.95	0.37	0.65
SRR0804-121K	120	± 10	50	0.796M	8.5	1.00	0.35	0.55
SRR0804-151K	150	± 10	53	0.796M	7.0	1.30	0.30	0.50
SRR0804-181K	180	± 10	53	0.796M	6.0	1.45	0.28	0.45
SRR0804-221K	220	± 10	55	0.796M	5.5	1.90	0.24	0.40
SRR0804-271K	270	± 10	50	0.796M	5.5	2.15	0.22	0.35
SRR0804-331K	330	± 10	60	0.796M	5.0	2.80	0.19	0.32
SRR0804-391K	390	± 10	55	0.796M	4.5	3.30	0.17	0.30
SRR0804-471K	470	± 10	60	0.796M	4.0	3.60	0.16	0.28

## Soldering Profile

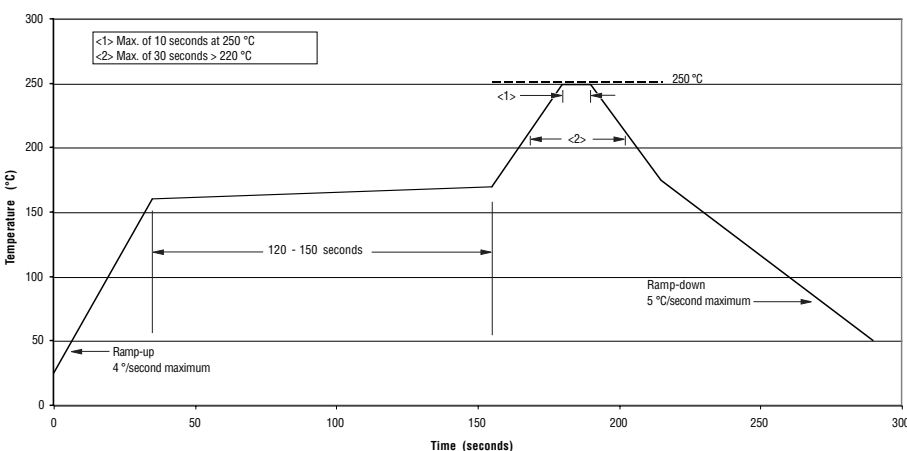

## General Specifications

Test Voltage.....1 V  
 Reflow soldering.....250 °C; 10 sec max.  
 (In compliance with JEDEC, J-STD-020C, Table 4-2)  
 Operating Temperature -40 °C to +125 °C  
 (Temperature rise included)  
 Storage Temperature...-40 °C to +125 °C  
 Resistance to Soldering Heat  
 .....250 °C, 10 sec. max.

## Materials

Core.....Ferrite DR&RI  
 Wire.....Enamelled copper  
 Base.....LCP E4008  
 Terminal.....Cu/Ni/Sn  
 Rated Current  
 .....Ind. drop 10 % typ. at Isat  
 Temperature Rise  
 .....40 °C max. at rated Irms  
 Packaging.....1000 pcs. per reel

## Product Dimensions

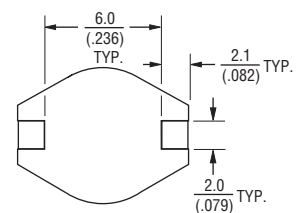
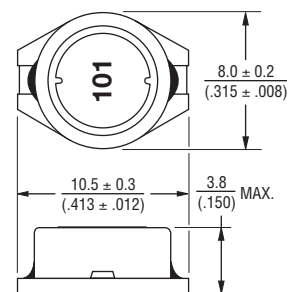

DIMENSIONS:  $\frac{\text{MM}}{\text{(INCHES)}}$

## Recommended Layout

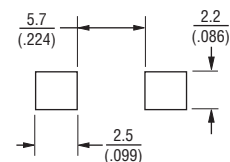

\*RoHS Directive 2002/95/EC Jan 27 2003 including Annex Specifications are subject to change without notice. Customers should verify actual device performance in their specific applications.

# SRR0804 Series - Shielded Power Inductors

**BOURNS®**

## Packaging Specifications

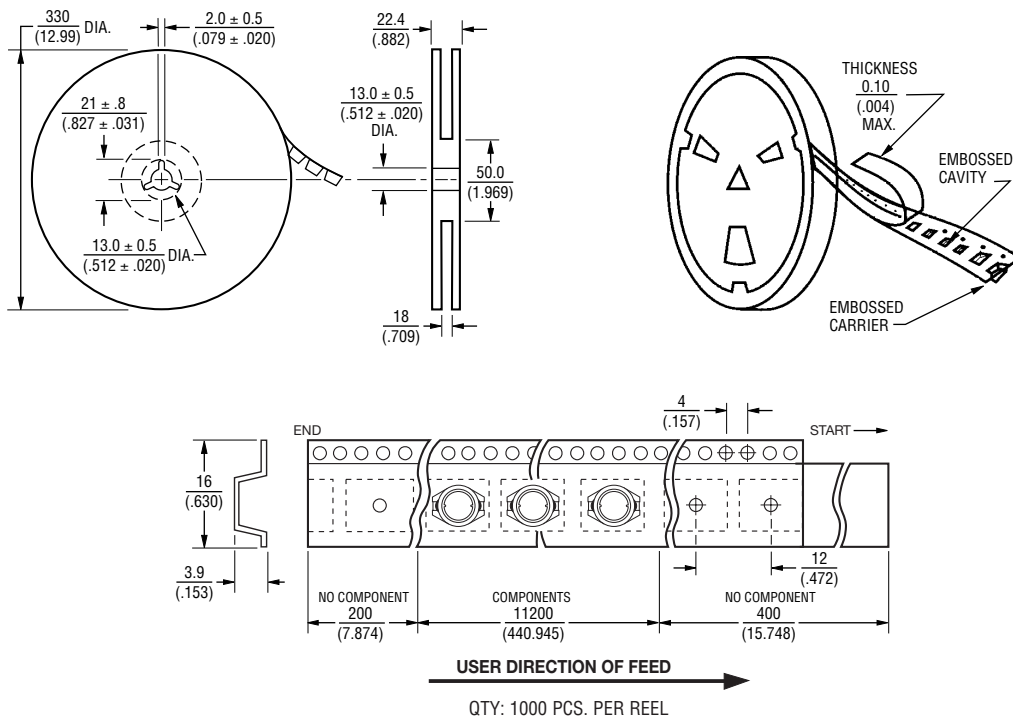

REV. 05/10

Specifications are subject to change without notice.  
Customers should verify actual device performance in their specific applications.



### Features

- Available in E12 series
- Low profile - 4.7 mm unit height
- High current
- Lead free
- RoHS compliant\*

### Applications

- Input/output of DC/DC converters
- Power supplies for:
  - Portable communication equipment
  - Camcorders
  - LCD TVs
  - Car radios

## SRR0805 Series - Shielded Power Inductor

### Electrical Specifications

Bourns Part No.	Inductance 1kHz		Q Ref.	Test Frequency (MHz)	SRF Min. (MHz)	RDC (Ω)	I rms Max. (A)	I sat Typ. (A)
	(μH)	Tol. %						
SRR0805-2R2M	2.2	± 20	18	7.96M	75.0	0.040	2.50	4.90
SRR0805-3R9M	3.9	± 20	20	7.96M	50.0	0.055	2.10	3.70
SRR0805-5R6M	5.6	± 20	20	7.96M	40.0	0.065	1.95	3.20
SRR0805-8R2M	8.2	± 20	19	7.96M	32.0	0.080	1.75	2.50
SRR0805-100M	10	± 20	40	2.52M	28.0	0.100	1.50	2.20
SRR0805-120M	12	± 20	40	2.52M	24.0	0.120	1.40	2.10
SRR0805-150M	15	± 20	40	2.52M	22.0	0.140	1.30	1.80
SRR0805-180Y	18	± 15	40	2.52M	19.0	0.160	1.20	1.70
SRR0805-220Y	22	± 15	38	2.52M	19.0	0.180	1.10	1.50
SRR0805-270Y	27	± 15	35	2.52M	15.5	0.200	1.00	1.40
SRR0805-330Y	33	± 15	40	2.52M	13.5	0.240	0.92	1.20
SRR0805-390Y	39	± 15	35	2.52M	12.0	0.260	0.84	1.10
SRR0805-470Y	47	± 15	32	2.52M	10.5	0.280	0.75	1.00
SRR0805-560K	56	± 10	30	2.52M	9.5	0.380	0.68	0.95
SRR0805-680K	68	± 10	28	2.52M	9.0	0.440	0.60	0.90
SRR0805-820K	82	± 10	28	2.52M	8.5	0.550	0.54	0.74
SRR0805-101K	100	± 10	45	0.796M	7.5	0.600	0.50	0.70
SRR0805-121K	120	± 10	42	0.796M	7.0	0.750	0.45	0.66
SRR0805-151K	150	± 10	39	0.796M	6.5	0.90	0.40	0.64
SRR0805-181K	180	± 10	41	0.796M	4.8	1.05	0.35	0.62
SRR0805-221K	220	± 10	38	0.796M	4.5	1.18	0.30	0.55
SRR0805-271K	270	± 10	37	0.796M	4.2	1.40	0.27	0.45
SRR0805-331K	330	± 10	36	0.796M	3.8	1.80	0.24	0.38
SRR0805-391K	390	± 10	35	0.796M	3.6	2.10	0.22	0.36
SRR0805-471K	470	± 10	34	0.796M	3.5	2.25	0.20	0.35
SRR0805-561K	560	± 10	32	0.796M	3.0	3.00	0.18	0.34
SRR0805-681K	680	± 10	32	0.796M	2.8	3.40	0.17	0.32
SRR0805-821K	820	± 10	35	0.796M	2.5	4.00	0.16	0.29
SRR0805-102K	1000	± 10	35	0.252M	2.2	5.00	0.15	0.24

### General Specifications

Test Voltage.....1 V  
 Reflow soldering.....250 °C; 10 sec max.  
 (In compliance with JEDEC, J-STD-020C, Table 4-2)  
 Operating Temperature ..-40 °C to +125 °C  
 (Temperature rise included)  
 Storage Temperature...-40 °C to +125 °C  
 Resistance to Soldering Heat  
 .....260 °C, 10 sec. max.

### Materials

Core .....Ferrite DR&RI  
 Wire .....Enameled copper  
 Base .....LCP E4008  
 Terminal.....Cu/Ni/Sn  
 Rated Current  
 .....Ind. drop 10 % typ. at Isat  
 Temperature Rise  
 .....40 °C max. at rated I rms  
 Packaging.....1000 pcs. per reel

### Product Dimensions

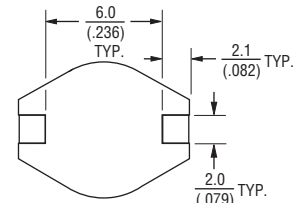
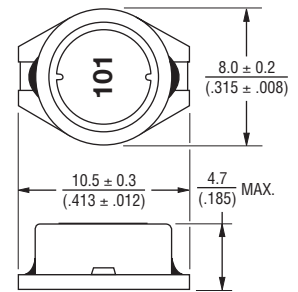

DIMENSIONS:  $\frac{\text{MM}}{\text{(INCHES)}}$

### Recommended Layout

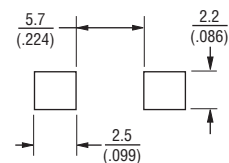

### Soldering Profile

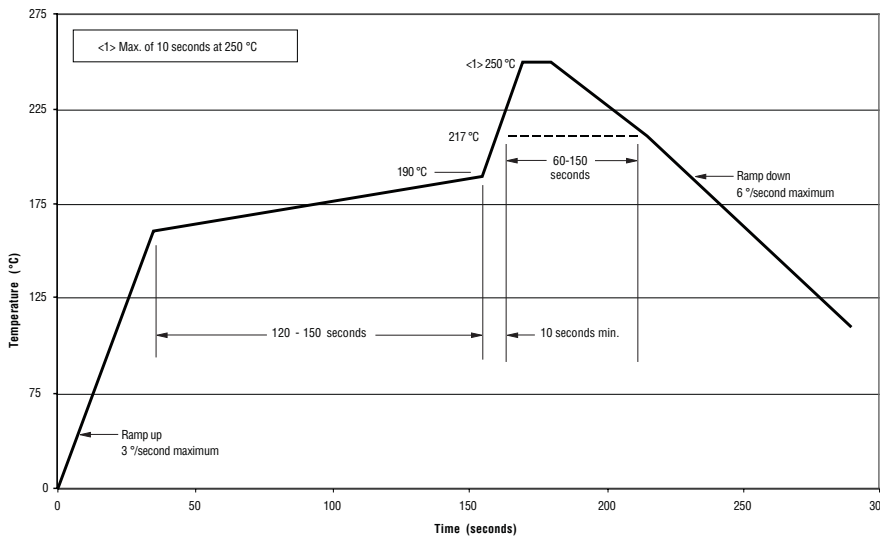

\*RoHS Directive 2002/95/EC Jan 27 2003 including Annex  
 Specifications are subject to change without notice.  
 Customers should verify actual device performance in their specific applications.

# SRR0805 Series - Shielded Power Inductor

**BOURNS®**

## Packaging Specifications

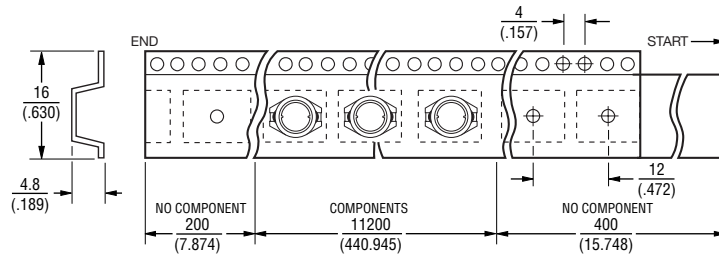
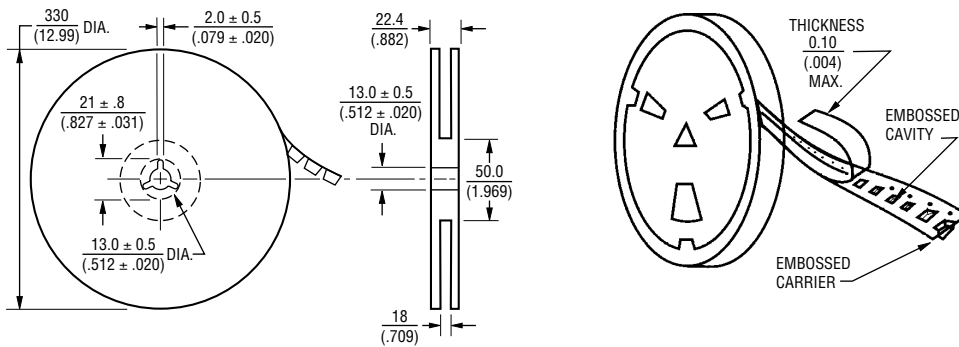

USER DIRECTION OF FEED  
QTY: 1000 PCS. PER REEL

DIMENSIONS:  $\frac{\text{MM}}{\text{(INCHES)}}$

REV. 05/10

Specifications are subject to change without notice.  
Customers should verify actual device performance in their specific applications.

\*RoHS COMPLIANT

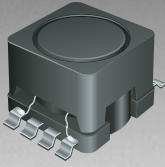

**BOURNS®**

## Features

- Available in E6 series
- High inductance up to 10 mH
- Low 6.0 mm profile
- Gull wing leads
- RoHS compliant\*

## Applications

- Input/output of DC/DC converters
- Power supplies for:
  - Portable communication equipment
  - Camcorders
  - LCD TVs
  - Car radios

# SRR0906 Series - SMD Shielded Power Inductors

## Electrical Specifications

Bourns Part No.	Inductance 1kHz		Q Ref.	Test Frequency (MHz)	SRF Min. (MHz)	RDC (Ω)	I rms Max. (A)	I sat Typ. (A)
	(μH)	Tol. %						
SRR0906-2R7ML	2.7	± 20	23	7.96M	85.0	0.032	3.20	5.80
SRR0906-3R5ML	3.5	± 20	23	7.96M	80.0	0.036	2.90	5.20
SRR0906-4R7ML	4.7	± 20	23	7.96M	40.0	0.040	2.70	4.30
SRR0906-5R6ML	5.6	± 20	23	7.96M	57.0	0.046	2.50	4.20
SRR0906-6R8ML	6.8	± 20	23	7.96M	38.0	0.050	2.30	3.40
SRR0906-8R2ML	8.2	± 20	23	7.96M	30.0	0.055	2.10	3.20
SRR0906-100ML	10	± 20	35	2.52M	29.0	0.080	1.80	2.70
SRR0906-120ML	12	± 20	35	2.52M	26.0	0.085	1.70	2.60
SRR0906-150ML	15	± 20	35	2.52M	23.0	0.100	1.60	2.40
SRR0906-180ML	18	± 20	35	2.52M	22.0	0.110	1.50	2.00
SRR0906-220ML	22	± 20	35	2.52M	19.0	0.130	1.40	1.90
SRR0906-270ML	27	± 20	35	2.52M	17.0	0.140	1.30	1.80
SRR0906-330ML	33	± 20	35	2.52M	15.0	0.150	1.20	1.60
SRR0906-390ML	39	± 20	35	2.52M	14.0	0.160	1.10	1.40
SRR0906-470ML	47	± 20	35	2.52M	12.0	0.180	1.00	1.30
SRR0906-560ML	56	± 20	35	2.52M	12.0	0.300	0.93	1.20
SRR0906-680ML	68	± 20	40	2.52M	9.0	0.350	0.85	1.00
SRR0906-820ML	82	± 20	40	2.52M	8.0	0.370	0.78	0.90
SRR0906-101YL	100	±15	40	0.796M	7.5	0.420	0.70	0.90
SRR0906-121YL	120	±15	40	0.796M	7.0	0.480	0.65	0.75
SRR0906-151YL	150	±15	40	0.796M	6.0	0.550	0.60	0.70
SRR0906-181YL	180	±15	40	0.796M	5.5	0.820	0.52	0.70
SRR0906-221YL	220	±15	40	0.796M	5.0	1.000	0.48	0.60
SRR0906-271YL	270	±15	40	0.796M	5.0	1.100	0.44	0.55
SRR0906-331YL	330	±15	40	0.796M	4.5	1.300	0.40	0.51
SRR0906-391YL	390	±15	40	0.796M	4.2	1.400	0.38	0.50
SRR0906-471YL	470	±15	40	0.796M	4.0	1.600	0.35	0.40
SRR0906-561YL	560	±15	60	0.796M	3.2	2.700	0.28	0.35
SRR0906-681YL	680	±15	60	0.796M	2.7	3.200	0.25	0.33
SRR0906-821YL	820	±15	85	0.796M	2.6	3.500	0.23	0.30
SRR0906-102YL	1000	±15	100	0.252M	2.3	4.000	0.22	0.26
SRR0906-122YL	1200	±15	100	0.252M	2.3	4.400	0.20	0.24
SRR0906-152YL	1500	±15	100	0.252M	2.0	5.200	0.18	0.22
SRR0906-182YL	1800	±15	100	0.252M	1.7	7.000	0.17	0.20
SRR0906-222YL	2200	±15	100	0.252M	1.5	8.500	0.16	0.18
SRR0906-272YL	2700	±15	100	0.252M	1.4	9.200	0.14	0.17
SRR0906-332YL	3300	±15	100	0.252M	1.3	11.000	0.12	0.15
SRR0906-392YL	3900	±15	100	0.252M	1.2	16.000	0.11	0.13
SRR0906-472YL	4700	±15	100	0.252M	1.0	19.000	0.10	0.11
SRR0906-562YL	5600	±15	100	0.252M	0.9	21.000	0.09	0.11
SRR0906-682YL	6800	±15	100	0.252M	0.9	24.000	0.09	0.10
SRR0906-822YL	8200	±15	100	0.252M	0.8	31.000	0.08	0.09
SRR0906-103YL	10000	±15	100	0.0796M	0.7	38.000	0.07	0.08

Multiple windings possible (up to four windings).

## Electrical Schematic



DIMENSIONS:  $\frac{\text{MM}}{\text{(INCHES)}}$

## General Specifications

Test Voltage.....1 V  
 Reflow Soldering ...230 °C, 50 sec. max.  
 Operating Temperature ..-40 °C to +125 °C  
 (Temperature rise included)  
 Storage Temperature...-40 °C to +125 °C  
 Resistance to Soldering Heat  
 .....260 °C for 5 sec.

## Materials

Core.....Ferrite DR and RI core  
 Wire.....Enamelled copper  
 Base.....LCP  
 Terminal .....Cu/Ni/Sn  
 Adhesive .....Epoxy resin  
 Rated Current .Ind. drop 10 % typ. at Isat  
 Temperature Rise  
 .....40 °C max. at rated I rms  
 Packaging.....600 pcs. per reel

## Product Dimensions

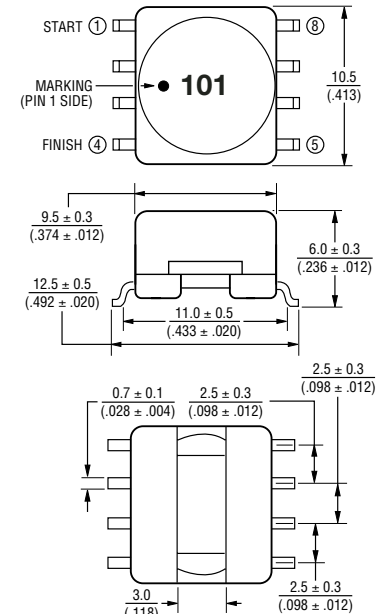

## Recommended Layout

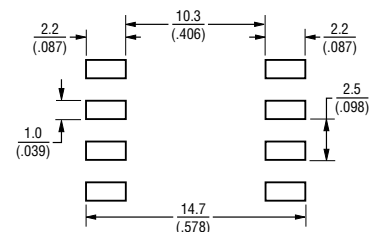

\*RoHS Directive 2002/95/EC Jan 27 2003 including Annex  
 Specifications are subject to change without notice.  
 Customers should verify actual device performance in their specific applications.

# SRR0906 Series - Shielded Power Inductors

**BOURNS®**

## Packaging Specifications

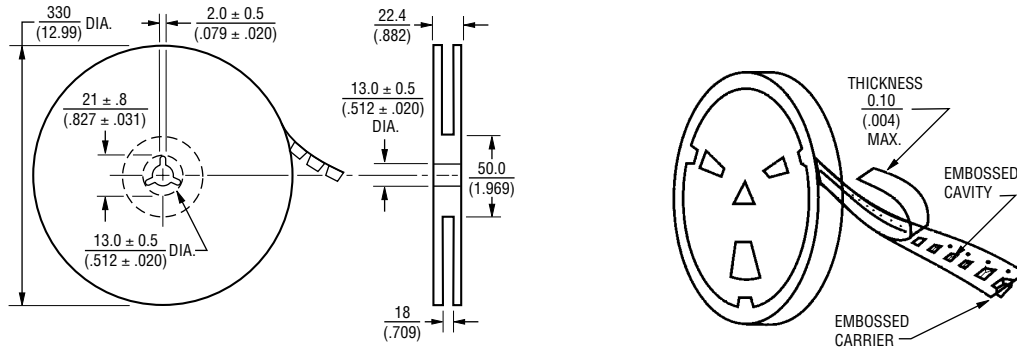

DIMENSIONS:  $\frac{\text{MM}}{\text{(INCHES)}}$

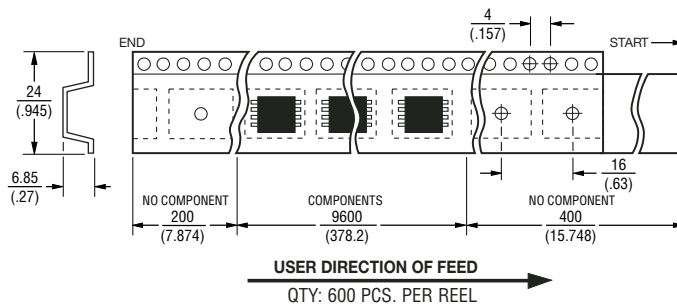

REV. 05/05

Specifications are subject to change without notice.  
Customers should verify actual device performance in their specific applications.

\*RoHS COMPLIANT

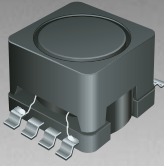

**BOURNS®**

### Features

- Available in E6 series, E12 series optional
- High inductance up to 15 mH
- High current up to 5.6 A
- Gull wing leads
- RoHS compliant\*

### Applications

- Input/output of DC/DC converters
- Power supplies for:
  - Portable communication equipment
  - Camcorders
  - LCD TVs
  - Car radios

## SRR0908 Series - SMD Shielded Power Inductors

### Electrical Specifications

Bourns Part No.	Inductance 1 kHz		Q Ref.	Test Frequency (MHz)	SRF Min. (MHz)	RDC (ohms)	I rms Max. (A)	I sat Typ. (A)
	(µH)	Tol. %						
SRR0908-1R5ML	1.5	± 20	20	7.96M	65.0	0.014	5.60	10.00
SRR0908-2R7ML	2.7	± 20	20	7.96M	50.0	0.019	4.80	7.70
SRR0908-3R9ML	3.9	± 20	20	7.96M	35.0	0.021	4.40	6.60
SRR0908-5R6ML	5.6	± 20	18	7.96M	25.0	0.028	3.80	5.50
SRR0908-7R5ML	7.5	± 20	18	7.96M	15.0	0.032	3.40	4.60
SRR0908-100ML	10	± 20	33	2.52M	11.0	0.040	3.00	4.10
SRR0908-120ML	12	± 20	40	2.52M	11.0	0.050	2.50	4.00
SRR0908-150ML	15	± 20	45	2.52M	8.50	0.050	2.20	3.90
SRR0908-180ML	18	± 20	40	2.52M	8.50	0.075	2.00	3.80
SRR0908-220ML	22	± 20	35	2.52M	6.00	0.080	1.90	3.30
SRR0908-270ML	27	± 20	45	2.52M	6.00	0.090	1.80	2.90
SRR0908-330ML	33	± 20	40	2.52M	5.00	0.10	1.70	2.70
SRR0908-390ML	39	± 20	45	2.52M	5.00	0.14	1.50	2.40
SRR0908-470ML	47	± 20	40	2.52M	4.00	0.15	1.40	2.30
SRR0908-560ML	56	± 20	35	2.52M	3.00	0.17	1.35	2.10
SRR0908-680ML	68	± 20	30	2.52M	2.50	0.18	1.25	1.90
SRR0908-820ML	82	± 20	30	2.52M	2.40	0.26	1.05	1.90
SRR0908-101YL	100	± 15	40	0.796M	6.00	0.28	1.00	1.30
SRR0908-121YL	120	± 15	42	0.796M	5.70	0.34	0.90	1.10
SRR0908-151YL	150	± 15	45	0.796M	4.60	0.45	0.80	1.00
SRR0908-181YL	180	± 15	35	0.796M	4.20	0.50	0.70	1.00
SRR0908-221YL	220	± 15	35	0.796M	3.80	0.60	0.65	0.95
SRR0908-271YL	270	± 15	30	0.796M	3.40	0.70	0.60	0.75
SRR0908-331YL	330	± 15	30	0.796M	3.00	0.80	0.55	0.70
SRR0908-391YL	390	± 15	33	0.796M	2.60	1.00	0.50	0.65
SRR0908-471YL	470	± 15	30	0.796M	2.30	1.15	0.45	0.62
SRR0908-561YL	560	± 15	35	0.796M	2.20	1.50	0.38	0.55
SRR0908-681YL	680	± 15	30	0.796M	2.00	1.70	0.35	0.50
SRR0908-821YL	820	± 15	35	0.796M	1.90	2.20	0.32	0.45
SRR0908-102YL	1000	± 15	85	0.252M	1.80	2.50	0.30	0.41
SRR0908-152YL	1500	± 15	120	0.252M	1.30	4.00	0.25	0.35
SRR0908-222YL	2200	± 15	95	0.252M	1.00	5.00	0.20	0.29
SRR0908-332YL	3300	± 15	95	0.252M	0.90	8.00	0.15	0.24
SRR0908-472YL	4700	± 15	90	0.252M	0.80	12.00	0.12	0.19
SRR0908-682YL	6800	± 15	90	0.252M	0.60	16.50	0.10	0.16
SRR0908-822YL	8200	± 15	85	0.252M	0.50	24.00	0.10	0.14
SRR0908-103YL	10000	± 15	110	0.0796M	0.50	26.00	0.09	0.13
SRR0908-153YL	15000	± 15	130	0.0796M	0.40	40.00	0.08	0.12

Multiple windings possible (up to four windings).

### General Specifications

Test Voltage ..... 1 V  
 Reflow Soldering ... 230 °C, 50 sec. max.  
 Operating Temperature -40 °C to +125 °C  
 (Temperature rise included)  
 Storage Temperature... -40 °C to +125 °C  
 Resistance to Soldering Heat  
 ..... 260 °C for 5 sec.

### Materials

Core ..... Ferrite DR and RI core  
 Wire ..... Enameled copper  
 Base ..... LCP  
 Terminal ..... Cu/Ni/Sn  
 Adhesive ..... Epoxy resin  
 Rated Current  
 ..... Ind. drop 10 % typ. at Isat  
 Temperature Rise  
 ..... 40 °C max. at rated Irms  
 Packaging ..... 400 pcs. per reel

### Product Dimensions

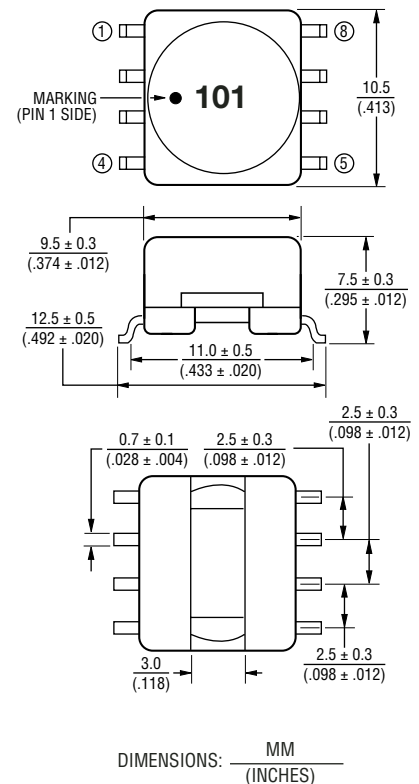

### Recommended Layout

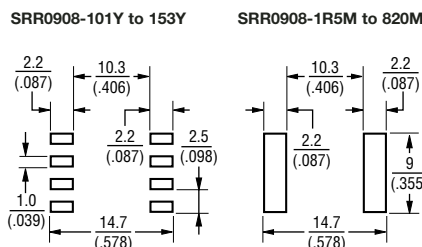

\*RoHS Directive 2002/95/EC Jan 27 2003 including Annex  
 Specifications are subject to change without notice.  
 Customers should verify actual device performance in their specific applications.



# SRR0908 Series - SMD Shielded Power Inductors

**BOURNS®**

## Packaging Specifications

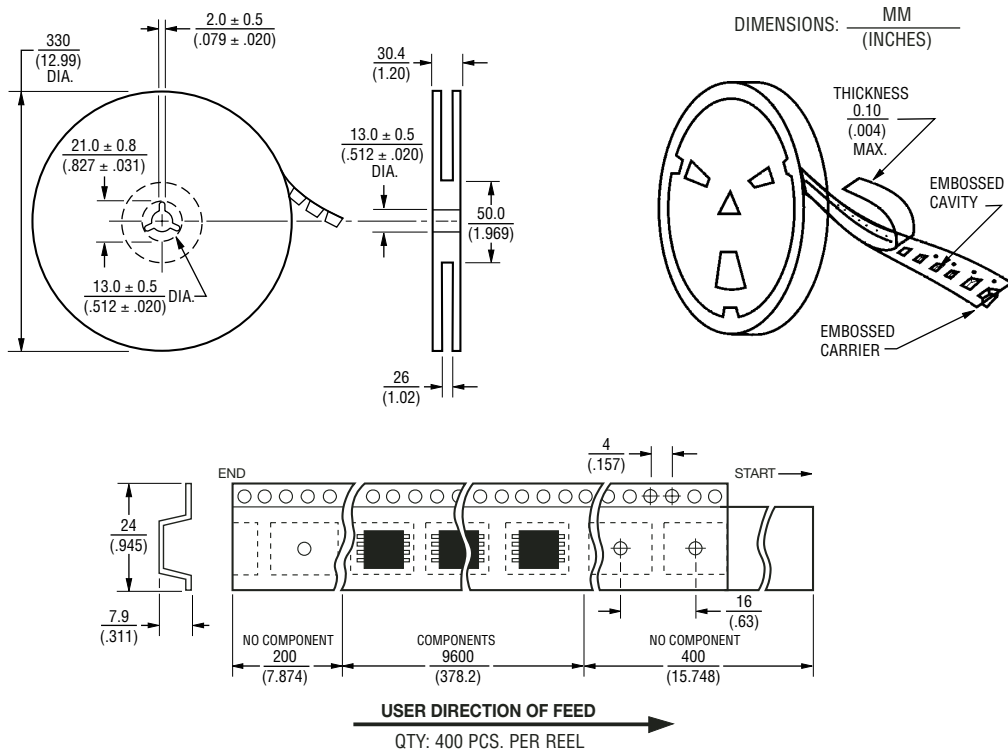

## Electrical Schematic

SRR0908-1R5M to 820M

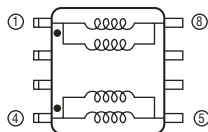

TOP VIEW (Typical Layout)

Termination of each individual winding may be either Pin 1, 2, 3, or 4.

Termination of opposite end of each individual winding may be either Pin 5, 6, 7, or 8

Windings will not be terminated to the same pin.

See "Recommended Layout" for SRR0908-1R5M to 820M.

SRR0908-101Y to 153Y

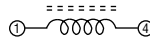

\*RoHS COMPLIANT

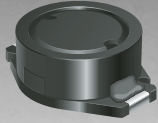

**BOURNS®**

## Features

- Available in E6 series
- Low profile of 3 mm
- High current
- Lead free
- RoHS compliant\*

## Applications

- Input/output of DC/DC converters
- Power supplies for:
  - Portable communication equipment
  - Camcorders
  - LCD TVs
  - Car radios

# SRR1003 Series - Shielded Power Inductors

## Electrical Specifications

Bourns Part No.	Inductance 1kHz		Q Ref.	Test Frequency (MHz)	SRF Min. (MHz)	RDC (Ω)	I rms Max. (A)	I sat Typ. (A)
	(μH)	Tol. %						
SRR1003-1R8M	1.8	± 20	10	7.96M	100.0	0.03	3.00	8.00
SRR1003-2R2M	2.2	± 20	11	7.96M	90.0	0.045	2.76	6.70
SRR1003-3R0M	3.0	± 20	11	7.96M	70.0	0.062	2.20	5.60
SRR1003-3R9M	3.9	± 20	10	7.96M	60.0	0.07	2.10	5.20
SRR1003-4R7M	4.7	± 20	10	7.96M	50.0	0.08	1.90	4.60
SRR1003-7R5M	7.5	± 20	10	7.96M	32.0	0.10	1.44	3.90
SRR1003-100M	10	± 20	18	2.52M	28.0	0.15	1.24	3.30
SRR1003-120M	12	± 20	20	2.52M	26.0	0.19	1.10	3.00
SRR1003-150M	15	± 20	20	2.52M	25.0	0.20	1.02	2.60
SRR1003-180M	18	± 20	20	2.52M	14.0	0.27	0.90	2.50
SRR1003-220M	22	± 20	17	2.52M	22.0	0.30	0.85	2.10
SRR1003-270M	27	± 20	17	2.52M	19.0	0.40	0.75	1.90
SRR1003-330M	33	± 20	17	2.52M	17.0	0.45	0.70	1.70
SRR1003-390M	39	± 20	18	2.52M	16.0	0.56	0.65	1.60
SRR1003-470M	47	± 20	18	2.52M	14.0	0.65	0.60	1.40
SRR1003-560M	56	± 20	15	2.52M	13.0	0.68	0.52	1.30
SRR1003-680M	68	± 20	15	2.52M	11.0	0.80	0.48	1.20
SRR1003-820M	82	± 20	20	2.52M	11.0	1.20	0.42	1.00
SRR1003-101M	100	± 20	23	0.796M	10.0	1.40	0.40	0.95
SRR1003-121M	120	± 20	22	0.796M	9.0	1.52	0.35	0.85
SRR1003-151M	150	± 20	23	0.796M	8.0	1.80	0.32	0.80
SRR1003-181M	180	± 20	20	0.796M	7.0	2.20	0.28	0.75
SRR1003-221M	220	± 20	20	0.796M	6.0	2.20	0.26	0.65
SRR1003-271Y	270	± 15	26	0.796M	4.1	3.10	0.22	0.60
SRR1003-331Y	330	± 15	26	0.796M	3.6	3.60	0.20	0.55
SRR1003-391Y	390	± 15	28	0.796M	2.6	4.60	0.18	0.46
SRR1003-471Y	470	± 15	28	0.796M	2.1	5.10	0.16	0.45

## General Specifications

Test Voltage.....1 V  
 Reflow soldering.....250 °C; 10 sec max.  
 (In compliance with JEDEC, J-STD-020C, Table 4-2)  
 Operating Temperature ..-40 °C to +125 °C  
 (Temperature rise included)  
 Storage Temperature...-40 °C to +125 °C  
 Resistance to Soldering Heat  
 .....250 °C, 10 sec. max.

## Materials

Core.....Ferrite DR and RI core  
 Wire.....Enamelled copper  
 Base.....LCP E4008  
 Terminal.....Cu/Ni/Sn  
 Rated Current  
 .....Ind. drop 10 % typ. at Isat  
 Temperature Rise  
 .....40 °C max. at rated Irms  
 Packaging.....1000 pcs. per reel

## Product Dimensions

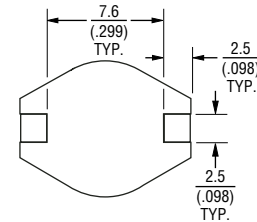
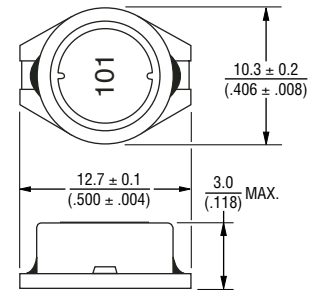

## Recommended Layout

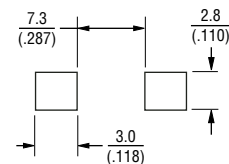

DIMENSIONS:  $\frac{\text{MM}}{(\text{INCHES})}$

## Soldering Profile

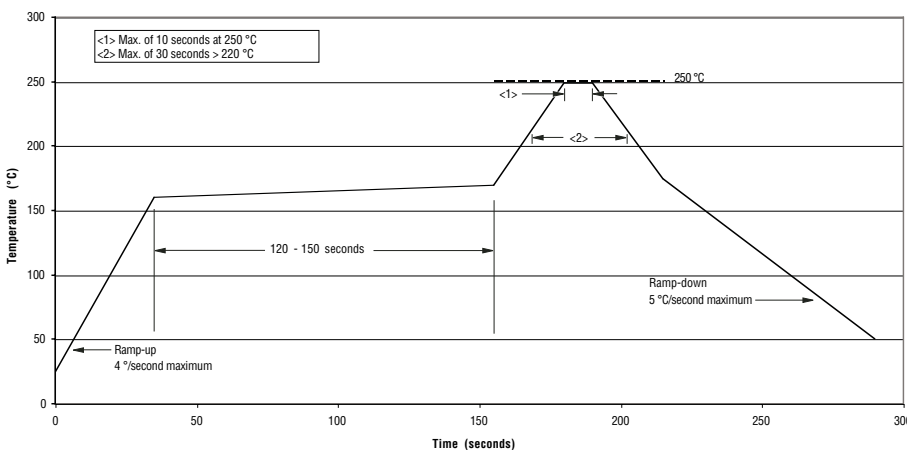

\*RoHS Directive 2002/95/EC Jan 27 2003 including Annex  
 Specifications are subject to change without notice.  
 Customers should verify actual device performance in their specific applications.

# SRR1003 Series - Shielded Power Inductors

**BOURNS®**

## Packaging Specifications

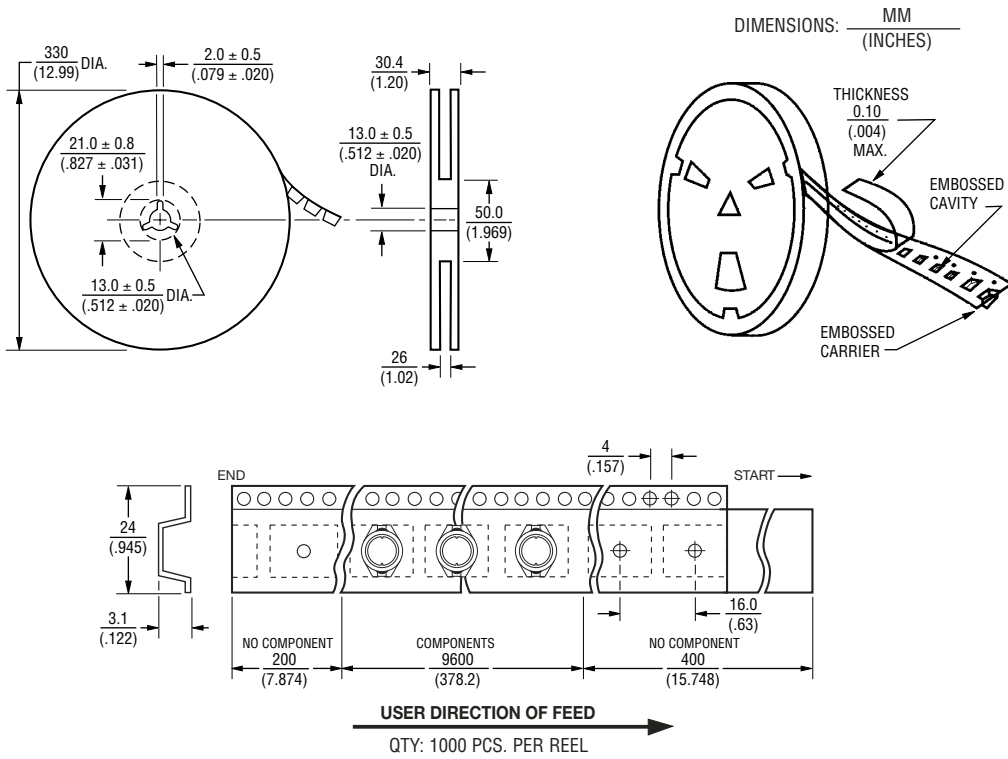

REV. 02/06

Specifications are subject to change without notice.  
Customers should verify actual device performance in their specific applications.



## Features

- Available in E12 series
- Unit height of 5.2 mm
- Current up to 4.5 A
- Lead free
- RoHS compliant\*

## Applications

- Input/output of DC/DC converters
- Power supplies for:
  - Portable communication equipment
  - Camcorders
  - LCD TVs
  - Car radios

# SRR1005 Series - Shielded Power Inductors

## Electrical Specifications

Bourns Part No.	Inductance 1kHz		Q Ref.	Test Frequency (MHz)	SRF Min. (MHz)	RDC ( $\Omega$ )	I rms Max. (A)	I sat Typ. (A)
	( $\mu$ H)	ToI. %						
SRR1005-1R0M	1.0	$\pm 20$	25	7.96M	120	0.017	4.50	8.00
SRR1005-1R5M	1.5	$\pm 20$	25	7.96M	100	0.020	3.60	7.00
SRR1005-2R2M	2.2	$\pm 20$	25	7.96M	90.0	0.027	3.10	6.10
SRR1005-3R0M	3.0	$\pm 20$	25	7.96M	80.0	0.030	2.90	5.00
SRR1005-3R3M	3.3	$\pm 20$	25	7.96M	75.0	0.039	3.30	3.90
SRR1005-4R7M	4.7	$\pm 20$	25	7.96M	50.0	0.040	2.50	3.80
SRR1005-6R8M	6.8	$\pm 20$	22	7.96M	35.0	0.075	2.20	2.80
SRR1005-7R0M	7.0	$\pm 20$	22	7.96M	32.0	0.055	2.20	3.20
SRR1005-100M	10	$\pm 20$	48	2.52M	30.0	0.065	2.00	3.00
SRR1005-120M	12	$\pm 20$	45	2.52M	25.0	0.080	1.80	2.30
SRR1005-150M	15	$\pm 20$	40	2.52M	20.0	0.085	1.70	2.10
SRR1005-180Y	18	$\pm 15$	35	2.52M	19.0	0.090	1.60	2.10
SRR1005-220Y	22	$\pm 15$	42	2.52M	18.0	0.100	1.40	1.90
SRR1005-270Y	27	$\pm 15$	40	2.52M	17.0	0.120	1.30	1.60
SRR1005-330Y	33	$\pm 15$	40	2.52M	15.0	0.160	1.20	1.56
SRR1005-390Y	39	$\pm 15$	40	2.52M	13.0	0.180	1.05	1.40
SRR1005-470Y	47	$\pm 15$	35	2.52M	12.0	0.190	1.00	1.30
SRR1005-560Y	56	$\pm 15$	35	2.52M	11.0	0.210	0.90	1.10
SRR1005-680Y	68	$\pm 15$	35	2.52M	9.0	0.340	0.82	1.10
SRR1005-820Y	82	$\pm 15$	35	2.52M	8.0	0.380	0.75	0.95
SRR1005-101K	100	$\pm 10$	35	0.796M	7.5	0.420	0.68	0.90
SRR1005-121K	120	$\pm 10$	30	0.796M	7.2	0.460	0.60	0.80
SRR1005-151K	150	$\pm 10$	28	0.796M	6.2	0.520	0.55	0.66
SRR1005-181K	180	$\pm 10$	28	0.796M	5.8	0.700	0.50	0.65
SRR1005-221K	220	$\pm 10$	30	0.796M	5.2	0.800	0.45	0.63
SRR1005-271K	270	$\pm 10$	30	0.796M	4.8	1.100	0.40	0.52
SRR1005-331K	330	$\pm 10$	30	0.796M	4.5	1.200	0.35	0.48
SRR1005-391K	390	$\pm 10$	25	0.796M	4.2	1.400	0.33	0.45
SRR1005-471K	470	$\pm 15$	40	0.796M	3.0	1.600	0.30	0.45
SRR1005-561K	560	$\pm 10$	40	0.796M	2.7	1.800	0.28	0.42
SRR1005-681K	680	$\pm 10$	37	0.796M	2.6	2.300	0.26	0.38
SRR1005-821K	820	$\pm 10$	37	0.796M	2.5	2.600	0.24	0.36
SRR1005-102K	1000	$\pm 10$	65	0.252M	2.0	3.200	0.22	0.32
SRR1005-122K	1200	$\pm 10$	58	0.252M	2.0	3.600	0.20	0.29
SRR1005-152K	1500	$\pm 10$	53	0.252M	1.6	5.200	0.17	0.24
SRR1005-182K	1800	$\pm 10$	65	0.252M	1.4	5.700	0.16	0.23
SRR1005-222K	2200	$\pm 10$	55	0.252M	1.4	6.500	0.14	0.21
SRR1005-272K	2700	$\pm 10$	55	0.252M	1.2	8.600	0.12	0.18
SRR1005-332K	3300	$\pm 10$	50	0.252M	1.2	10.00	0.10	0.17

## General Specifications

Test Voltage.....1 V  
 Reflow soldering.....250 °C; 10 sec max.  
 (In compliance with JEDEC, J-STD-020C, Table 4-2)  
 Operating Temperature...-40 °C to +125 °C  
 (Temperature rise included)  
 Storage Temperature...-40 °C to +125 °C  
 Resistance to Soldering Heat  
 .....250 °C, 10 sec. max.

## Materials

Core.....Ferrite DR and RI core  
 Wire.....Enameled copper  
 Base .....DAP  
 Terminal .....Cu/Ni/Sn  
 Rated Current  
 .....Ind. drop 10 % typ. at Isat  
 Temperature Rise  
 .....40 °C max. at rated I rms  
 Packaging.....600 pcs. per reel

## Product Dimensions

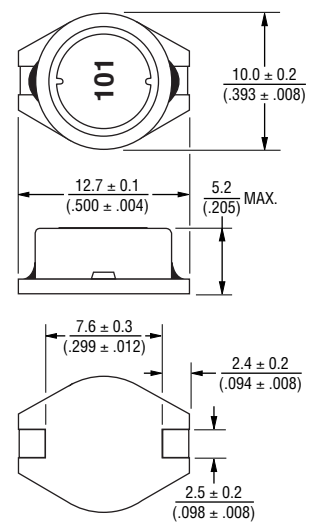

## Recommended Layout

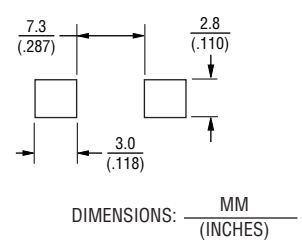

\*RoHS Directive 2002/95/EC Jan 27 2003 including Annex Specifications are subject to change without notice. Customers should verify actual device performance in their specific applications.

# SRR1005 Series - Shielded Power Inductors

**BOURNS®**

## Soldering Profile

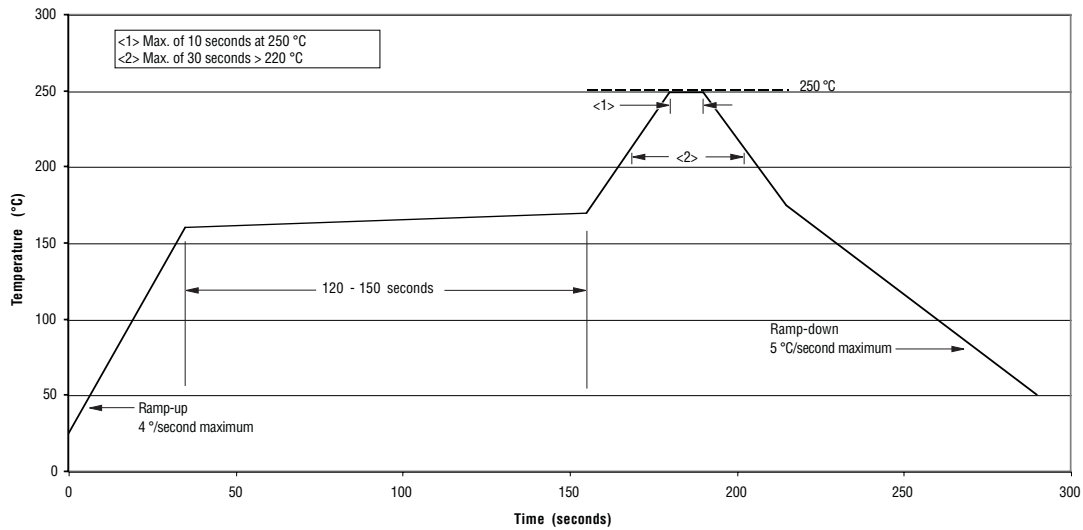

## Packaging Specifications

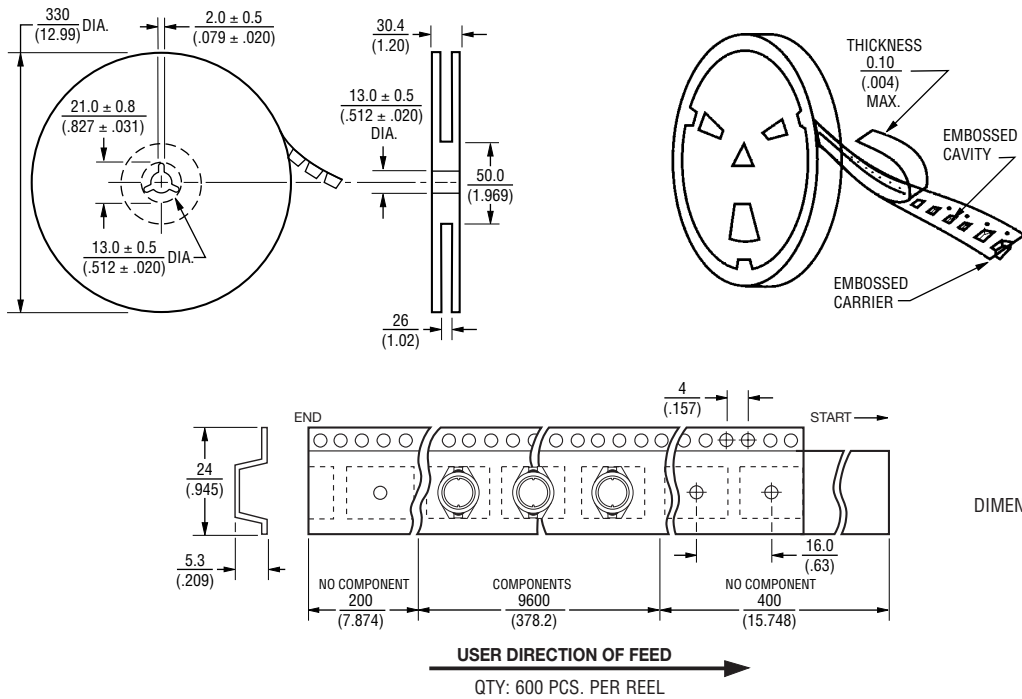

REV. 05/10

Specifications are subject to change without notice.

Customers should verify actual device performance in their specific applications.

\*RoHS COMPLIANT

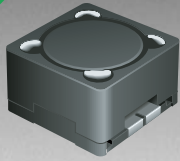

**BOURNS®**

## Features

- E6 series optional
- Unit height of 5.5 mm
- Current up to 5 A
- J-hook leads
- RoHS compliant\*

## Applications

- Input/output of DC/DC converters
- Power supplies for:
  - Portable communication equipment
  - Camcorders
  - LCD TVs
  - Car radios

# SRR1205 Series - Shielded High Power Inductors

## Electrical Specifications

Bourns Part No.	Inductance 1kHz		Q Ref.	Test Frequency (MHz)	SRF Min. (MHz)	RDC (mΩ)	I rms Max. (A)	I sat Typ. (A)
	(μH)	Tol. %						
SRR1205-2R5ML	2.5	± 20	18	7.96M	27.0	24	5.00	10.00
SRR1205-3R3ML	3.3	± 20	20	7.96M	25.0	30	4.50	9.20
SRR1205-5R0ML	5.0	± 20	20	7.96M	21.0	35	4.00	8.20
SRR1205-7R5ML	7.5	± 20	20	7.96M	17.0	40	3.50	7.80
SRR1205-100ML	10	± 20	21	2.52M	15.0	54	3.00	6.00
SRR1205-120ML	12	± 20	20	2.52M	13.0	65	2.80	5.60
SRR1205-150ML	15	± 20	20	2.52M	11.0	70	2.70	5.30
SRR1205-180ML	18	± 20	20	2.52M	10.0	82	2.60	4.80
SRR1205-220ML	22	± 20	19	2.52M	9.0	95	2.40	4.60
SRR1205-270ML	27	± 20	18	2.52M	8.0	120	2.00	4.00
SRR1205-330ML	33	± 20	18	2.52M	8.0	145	1.80	3.50
SRR1205-390ML	39	± 20	18	2.52M	7.5	160	1.65	3.20
SRR1205-500YL	50	± 15	18	2.52M	7.0	200	1.50	2.80
SRR1205-560YL	56	± 15	18	2.52M	7.0	240	1.40	2.50
SRR1205-680YL	68	± 15	17	2.52M	6.5	280	1.30	2.40
SRR1205-750YL	75	± 15	17	2.52M	6.0	330	1.20	2.20
SRR1205-101KL	100	± 10	12	0.796M	5.0	400	1.00	2.00
SRR1205-121KL	120	± 10	10	0.796M	4.5	500	0.90	1.60
SRR1205-151KL	150	± 10	10	0.796M	4.0	580	0.80	1.50
SRR1205-181KL	180	± 10	9	0.796M	3.5	750	0.70	1.40
SRR1205-221KL	220	± 10	9	0.796M	3.0	840	0.65	1.30
SRR1205-271KL	270	± 10	9	0.796M	2.5	1000	0.60	1.00
SRR1205-331KL	330	± 10	7	0.796M	2.0	1340	0.54	0.88
SRR1205-391KL	390	± 10	7	0.796M	2.0	1500	0.50	0.80
SRR1205-471KL	470	± 10	7	0.796M	2.0	1980	0.45	0.72
SRR1205-561KL	560	± 10	6	0.796M	1.5	2200	0.40	0.65
SRR1205-681KL	680	± 10	6	0.796M	1.5	2400	0.35	0.60
SRR1205-821KL	820	± 10	5	0.796M	1.0	3000	0.30	0.57

## General Specifications

Test Voltage.....1 V  
 Reflow Soldering ...230 °C, 50 sec. max.  
 Operating Temperature ..-40 °C to +125 °C  
 (Temperature rise included)  
 Storage Temperature...-40 °C to +125 °C  
 Resistance to Soldering Heat  
 .....260 °C for 5 sec.

## Materials

Core.....Ferrite DR and RI core  
 Wire.....Enameled copper  
 Base.....LCP E4008  
 Terminal.....Cu/Ni/Sn  
 Rated Current  
 .....Ind. drop 10 % typ. at Isat  
 Temperature Rise  
 .....40 °C max. at rated I rms  
 Packaging.....600 pcs. per reel

## Product Dimensions

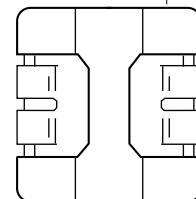
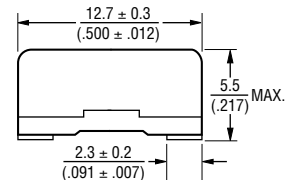
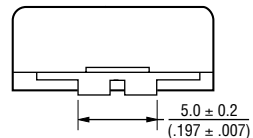
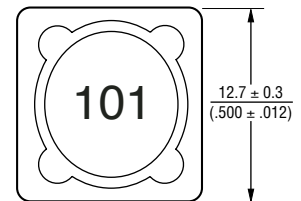

DIMENSIONS:  $\frac{\text{MM}}{\text{(INCHES)}}$

## Electrical Schematic

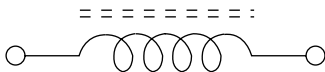

## Recommended Layout

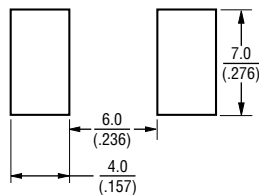

# SRR1205 Series - Shielded High Power Inductors

**BOURNS®**

## Packaging Specifications

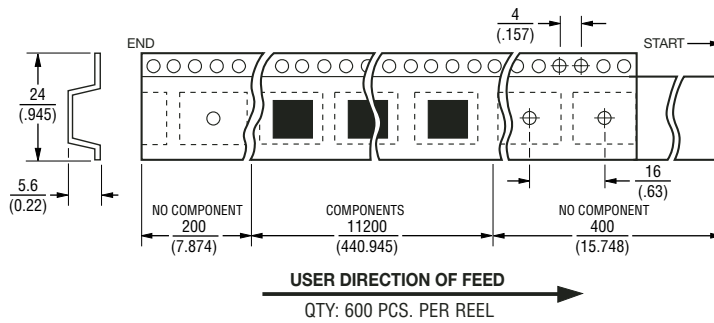
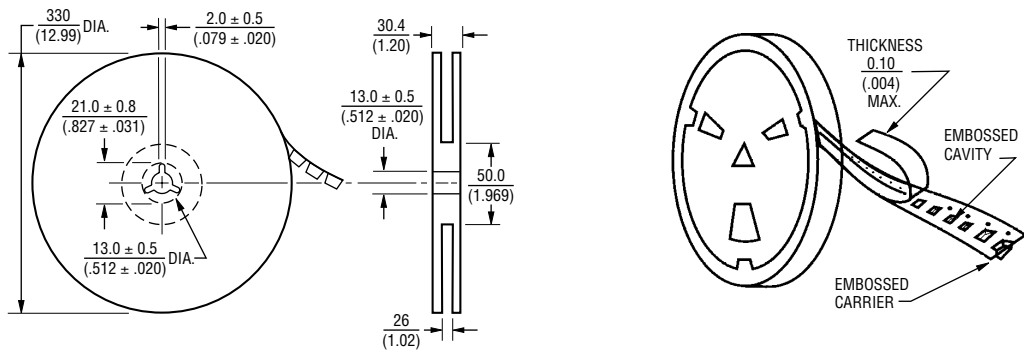

DIMENSIONS:  $\frac{\text{MM}}{\text{(INCHES)}}$

REV. 05/05

Specifications are subject to change without notice.  
Customers should verify actual device performance in their specific applications.

RoHS COMPLIANT

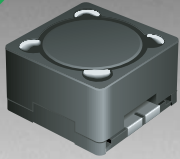

**BOURNS®**

## Features

- Available in E12 series
- Unit height of 6.5 mm
- Current up to 6 A
- RoHS compliant\*

## Applications

- Input/output of DC/DC converters
- Power supplies for:
  - Portable communication equipment
  - Camcorders
  - LCD TVs
  - Car radios

# SRR1206 Series - Shielded High Power Inductors

### Electrical Specifications

Bourns Part No.	Inductance 1kHz		Q Ref.	Test Frequency (MHz)	SRF Min. (MHz)	RDC (mΩ)	I rms Max. (A)	I sat Typ. (A)
	(μH)	Tol. %						
SRR1206-2R5ML	2.5	± 20	19	7.96M	30.0	16	6.20	10.00
SRR1206-5R0ML	5.0	± 20	21	7.96M	25.0	22	4.70	8.30
SRR1206-7R5ML	7.5	± 20	22	7.96M	22.0	25	3.80	6.90
SRR1206-100ML	10	± 20	18	2.52M	18.0	35	3.30	5.70
SRR1206-120ML	12	± 20	18	2.52M	17.0	38	3.00	5.50
SRR1206-150ML	15	± 20	19	2.52M	16.0	42	2.80	5.10
SRR1206-180ML	18	± 20	19	2.52M	14.0	50	2.50	4.70
SRR1206-220ML	22	± 20	21	2.52M	11.0	62	2.30	3.80
SRR1206-270ML	27	± 20	21	2.52M	10.0	68	2.00	3.70
SRR1206-330YL	33	± 15	21	2.52M	9.0	90	1.90	3.10
SRR1206-390YL	39	± 15	23	2.52M	9.0	100	1.75	3.00
SRR1206-470YL	47	± 15	22	2.52M	7.0	130	1.60	2.50
SRR1206-560YL	56	± 15	21	2.52M	7.0	155	1.45	2.50
SRR1206-680YL	68	± 15	18	2.52M	7.0	170	1.30	2.20
SRR1206-820YL	82	± 15	16	2.52M	6.0	185	1.20	2.10
SRR1206-101YL	100	± 15	13	0.796M	6.0	220	1.10	1.90
SRR1206-121YL	120	± 15	13	0.796M	5.0	260	1.00	1.80
SRR1206-151KL	150	± 10	13	0.796M	5.0	320	0.90	1.60
SRR1206-181KL	180	± 10	12	0.796M	4.5	330	0.80	1.30
SRR1206-221KL	220	± 10	11	0.796M	4.0	460	0.70	1.20
SRR1206-271KL	270	± 10	11	0.796M	3.5	520	0.65	1.10
SRR1206-331KL	330	± 10	11	0.796M	3.0	660	0.60	1.00
SRR1206-391KL	390	± 10	13	0.796M	2.5	870	0.55	0.95
SRR1206-471KL	470	± 10	12	0.796M	2.5	970	0.50	0.83
SRR1206-561KL	560	± 10	13	0.796M	2.0	1320	0.45	0.80
SRR1206-681KL	680	± 10	11	0.796M	2.0	1500	0.40	0.70
SRR1206-821KL	820	± 10	10	0.796M	2.0	1700	0.35	0.65
SRR1206-102KL	1000	± 10	10	0.252M	1.8	2300	0.30	0.54
SRR1206-122KL	1200	± 10	10	0.252M	1.5	2650	0.25	0.51
SRR1206-152KL	1500	± 10	10	0.252M	1.2	3500	0.20	0.42

### Electrical Schematic

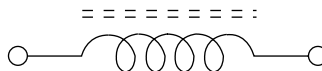

DIMENSIONS:  $\frac{\text{MM}}{\text{(INCHES)}}$

### General Specifications

Test Voltage ..... 1 V  
 Reflow Soldering ...230 °C, 50 sec. max.  
 Operating Temperature ..-40 °C to +125 °C  
 (Temperature rise included)  
 Storage Temperature...-40 °C to +125 °C  
 Resistance to Soldering Heat  
 .....260 °C for 5 sec.

### Materials

Core ..... Ferrite DR and RI core  
 Wire ..... Enameled copper  
 Base ..... LCP E4008  
 Terminal ..... Cu/Ni/Sn  
 Rated Current ..Ind. drop 10 % typ. at Isat  
 Temperature Rise  
 .....40 °C max. at rated I rms  
 Packaging.....600 pcs. per reel

### Product Dimensions

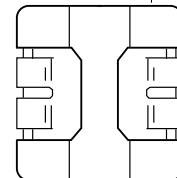
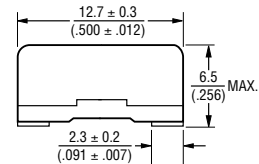
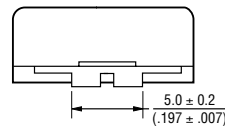
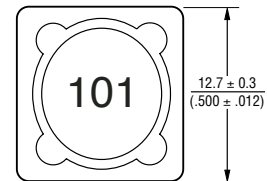

### Recommended Layout

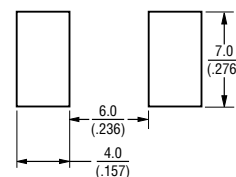

\*RoHS Directive 2002/95/EC Jan 27 2003 including Annex  
 Specifications are subject to change without notice.  
 Customers should verify actual device performance in their specific applications.



# SRR1206 Series - Shielded High Power Inductors

**BOURNS®**

## Packaging Specifications

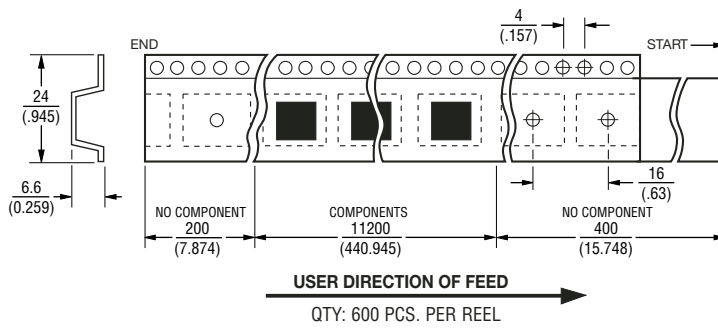
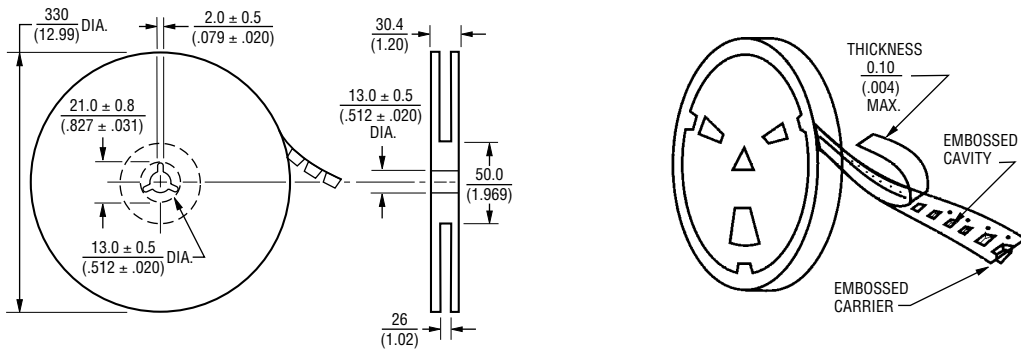

DIMENSIONS:  $\frac{\text{MM}}{\text{(INCHES)}}$

REV. 05/05

Specifications are subject to change without notice.  
Customers should verify actual device performance in their specific applications.

\*RoHS COMPLIANT

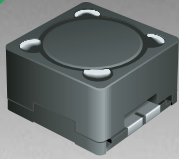

**BOURNS®**

## Features

- Available in E6 series
- Unit height of 8.5 mm
- Current up to 7.5 A
- RoHS compliant\*

## Applications

- Input/output of DC/DC converters
- Power supplies for:
  - Portable communication equipment
  - Camcorders
  - LCD TVs
  - Car radios

# SRR1208 Series - Shielded High Power Inductors

## Electrical Specifications

Bourns Part No.	Inductance 1kHz		Q Ref.	Test Frequency (MHz)	SRF Min. (MHz)	RDC (Ω)	I rms Max. (A)	I sat Typ. (A)
	(μH)	Tol. %						
SRR1208-2R5ML	2.5	± 20	20	7.96	37	0.011	7.50	10.00
SRR1208-4R5ML	4.5	± 20	24	7.96	30	0.014	6.50	10.00
SRR1208-6R5ML	6.5	± 20	25	7.96	20	0.018	6.00	8.40
SRR1208-100ML	10	± 20	20	2.52	15	0.021	5.00	6.70
SRR1208-120ML	12	± 20	19	2.52	11	0.025	4.80	6.50
SRR1208-150ML	15	± 20	21	2.52	11	0.036	4.00	5.60
SRR1208-180ML	18	± 20	21	2.52	9.0	0.040	3.80	4.00
SRR1208-220ML	22	± 20	23	2.52	7.0	0.043	3.50	4.00
SRR1208-270ML	27	± 20	23	2.52	6.5	0.048	3.00	4.30
SRR1208-330YL	33	± 15	23	2.52	6.5	0.062	2.80	3.80
SRR1208-390YL	39	± 15	25	2.52	6.0	0.076	2.50	3.40
SRR1208-470YL	47	± 15	24	2.52	5.0	0.085	2.20	3.10
SRR1208-560YL	56	± 15	23	2.52	5.0	0.110	2.00	2.80
SRR1208-680YL	68	± 15	20	2.52	5.0	0.135	1.80	2.60
SRR1208-820YL	82	± 15	18	2.52	4.0	0.150	1.60	2.30
SRR1208-101YL	100	± 15	15	0.796	4.0	0.170	1.50	2.10
SRR1208-121YL	120	± 15	15	0.796	3.0	0.190	1.40	2.00
SRR1208-151YL	150	± 15	14	0.796	3.0	0.240	1.30	1.72
SRR1208-181YL	180	± 15	14	0.796	2.5	0.270	1.20	1.70
SRR1208-221KL	220	± 10	13	0.796	2.5	0.380	1.10	1.45
SRR1208-271KL	270	± 10	13	0.796	2.0	0.400	0.95	1.25
SRR1208-331KL	330	± 10	13	0.796	1.8	0.650	0.85	1.12
SRR1208-391KL	390	± 10	14	0.796	1.6	0.670	0.80	1.10
SRR1208-471KL	470	± 10	14	0.796	1.4	0.850	0.70	0.95
SRR1208-561KL	560	± 10	14	0.796	1.4	0.900	0.65	0.90
SRR1208-681KL	680	± 10	13	0.796	1.2	1.00	0.60	0.82
SRR1208-821KL	820	± 10	12	0.796	1.2	1.15	0.55	0.77
SRR1208-102KL	1000	± 10	11	0.252	1.0	1.65	0.50	0.67
SRR1208-122KL	1200	± 10	10	0.252	0.80	2.00	0.40	0.57
SRR1208-152KL	1500	± 10	10	0.252	0.75	2.35	0.36	0.55
SRR1208-182KL	1800	± 10	20	0.252	0.70	3.40	0.46	0.48
SRR1208-222KL	2200	± 10	20	0.252	0.65	4.20	0.40	0.42
SRR1208-272KL	2700	± 10	20	0.252	0.60	5.20	0.35	0.38
SRR1208-332KL	3300	± 10	20	0.252	0.50	6.40	0.32	0.35
SRR1208-392KL	3900	± 10	20	0.252	0.45	7.80	0.30	0.32
SRR1208-472KL	4700	± 10	20	0.252	0.42	9.60	0.28	0.30
SRR1208-562KL	5600	± 10	18	0.252	0.40	12.0	0.25	0.28
SRR1208-682KL	6800	± 10	18	0.252	0.38	15.2	0.22	0.25
SRR1208-822KL	8200	± 10	16	0.252	0.35	17.0	0.20	0.22
SRR1208-103KL	10000	± 10	24	0.0796	0.30	19.2	0.18	0.20

## Electrical Schematic

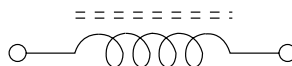

## General Specifications

Test Voltage ..... 1 V  
 Reflow Soldering ...230 °C, 50 sec. max.  
 Operating Temperature -40 °C to +125 °C  
 (Temperature rise included)  
 Storage Temperature...-40 °C to +125 °C  
 Resistance to Soldering Heat  
 .....260 °C for 5 sec.

## Materials

Core.....Ferrite DR and RI core  
 Wire.....Enameled copper  
 Base .....LCP E4008  
 Terminal .....Cu/Ni/Sn  
 Rated Current  
 .....Ind. drop 10 % typ. at Isat  
 Temperature Rise  
 .....40 °C max. at rated I rms  
 Packaging.....400 pcs. per reel

## Product Dimensions

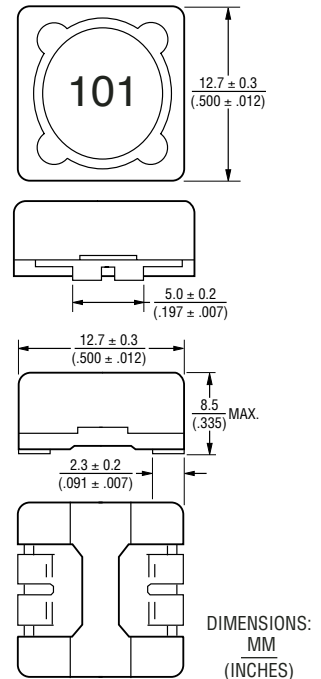

## Recommended Layout

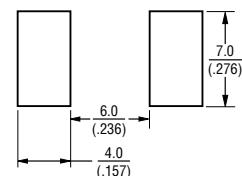

\*RoHS Directive 2002/95/EC Jan 27 2003 including Annex  
 Specifications are subject to change without notice.  
 Customers should verify actual device performance in their specific applications.

# SRR1208 Series - Shielded High Power Inductors

**BOURNS®**

## Packaging Specifications

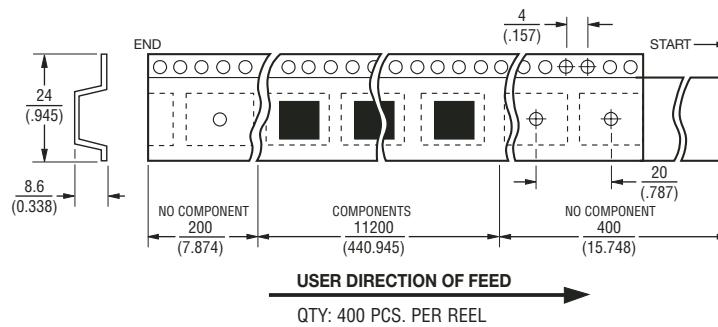
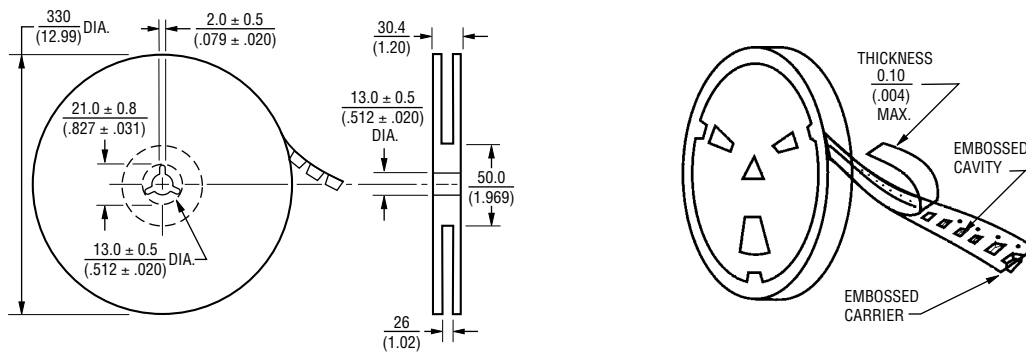

DIMENSIONS:  $\frac{\text{MM}}{\text{(INCHES)}}$

REV. 12/08

Specifications are subject to change without notice.  
Customers should verify actual device performance in their specific applications.

RoHS COMPLIANT



**BOURNS®**

## Features

- Available in E12 values
- Height of 4.5 mm maximum
- Current rating to 9.3 amps
- Lead free
- RoHS compliant\*

## Applications

- Input/output of DC/DC converters
- Power supplies for:
  - Portable communication equipment
  - Camcorders
  - LCD TVs
  - Car radios

# SRR1240 Series - Shielded SMD Power Inductors

### Electrical Specifications

Bourns Part No.	Inductance 100 kHz		Q Typ.	Test Frequency (MHz)	SRF Typ. (MHz)	RDC Max. (mΩ)	I rms Max. (A)	I sat Typ. (A)
	(μH)	Tol. %						
SRR1240-1R0Y	1.0	± 30	10	7.96	85	7.0	9.30	9.20
SRR1240-1R5Y	1.5	± 30	16	7.96	80	9.5	9.20	9.00
SRR1240-2R4Y	2.4	± 30	10	7.96	54	11.5	8.00	7.80
SRR1240-3R3Y	3.3	± 30	14	7.96	43	15.0	6.80	6.50
SRR1240-3R9Y	3.9	± 30	14	7.96	39	15.0	6.35	6.20
SRR1240-4R7M	4.7	± 20	16	7.96	33	18.0	6.00	5.60
SRR1240-5R6M	5.6	± 20	14	7.96	35	20.0	5.40	5.10
SRR1240-6R8M	6.8	± 20	14	7.96	34	23.0	5.20	4.70
SRR1240-8R2M	8.2	± 20	10	7.96	32	27.0	4.50	4.30
SRR1240-100M	10.0	± 20	17	2.52	27	32.0	4.00	4.00
SRR1240-120M	12.0	± 20	16	2.52	25	38.0	3.80	3.60
SRR1240-150M	15.0	± 20	16	2.52	22	47.0	3.50	3.20
SRR1240-180M	18.0	± 20	14	2.52	20	55.0	3.20	3.00
SRR1240-220M	22.0	± 20	18	2.52	16	67.5	3.00	2.60
SRR1240-270M	27.0	± 20	16	2.52	15.5	85.0	2.55	2.35
SRR1240-330M	33.0	± 20	19	2.52	15	97.0	2.30	2.10
SRR1240-390M	39.0	± 20	14	2.52	14	120.0	2.15	2.00
SRR1240-470M	47.0	± 20	19	2.52	13	135.0	2.00	1.80
SRR1240-560M	56.0	± 20	16	2.52	12	170.0	1.80	1.65
SRR1240-680M	68.0	± 20	19	2.52	11	200.0	1.50	1.50
SRR1240-820M	82.0	± 20	16	2.52	10	250.0	1.35	1.35
SRR1240-101M	100.0	± 20	14	0.796	8	300.0	1.25	1.20
SRR1240-121K	120.0	± 10	12	0.796	7.8	370.0	1.20	1.15
SRR1240-151K	150.0	± 10	12	0.796	7.5	440.0	1.10	1.05
SRR1240-181K	180.0	± 10	12	0.796	7.0	550.0	0.98	0.95
SRR1240-221K	220.0	± 10	12	0.796	6.6	660.0	0.92	0.90
SRR1240-271K	270.0	± 10	10	0.796	6.0	780.0	0.80	0.80
SRR1240-331K	330.0	± 10	12	0.796	5.5	950.0	0.75	0.75
SRR1240-391K	390.0	± 10	12	0.796	5.0	1150.0	0.70	0.65
SRR1240-471K	470.0	± 10	12	0.796	4.5	1350.0	0.62	0.60
SRR1240-561K	560.0	± 10	12	0.796	4.0	1500.0	0.55	0.52
SRR1240-681K	680.0	± 10	14	0.796	3.8	2000.0	0.50	0.48
SRR1240-821K	820.0	± 10	10	0.796	3.5	2400.0	0.45	0.42
SRR1240-102K	1000.0	± 10	16	0.252	2.8	3000.0	0.42	0.40

### General Specifications

Test Voltage.....0.1 V  
 Reflow Soldering ...230 °C, 50 sec. max.  
 Operating Temperature ...-40 °C to +125 °C  
 (Temperature rise included)  
 Storage Temperature...-40 °C to +125 °C  
 Resistance to Soldering Heat  
 .....260 °C for 10 sec.

### Materials

Core .....Ferrite DR and RI  
 Wire .....Enameled copper wire 130  
 Terminal.....Cu/Ni/Sn  
 Rated Current  
 .....Ind. drop 25 % typ. at Isat  
 Temperature Rise .....40 °C max.  
 at rated Irms  
 Packaging .....800 pcs. per reel

### Product Dimensions

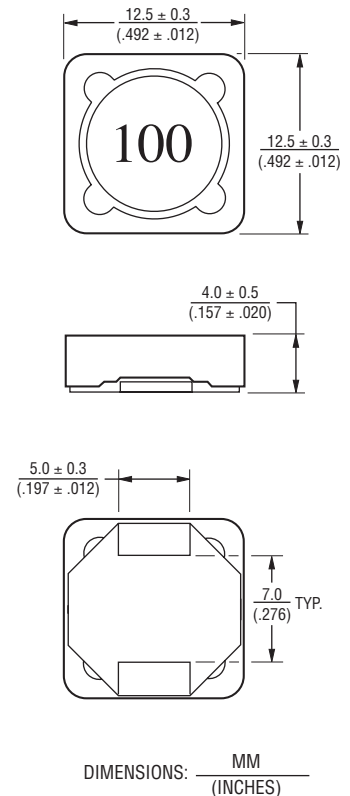

### Electrical Schematic

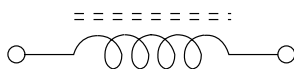

### Recommended Layout

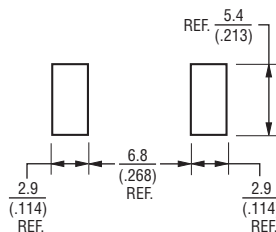

\*RoHS Directive 2002/95/EC Jan 27 2003 including Annex  
 Specifications are subject to change without notice.  
 Customers should verify actual device performance in their specific applications.

# SRR1240 Series - Shielded SMD Power Inductors

**BOURNS®**

## Packaging Specifications

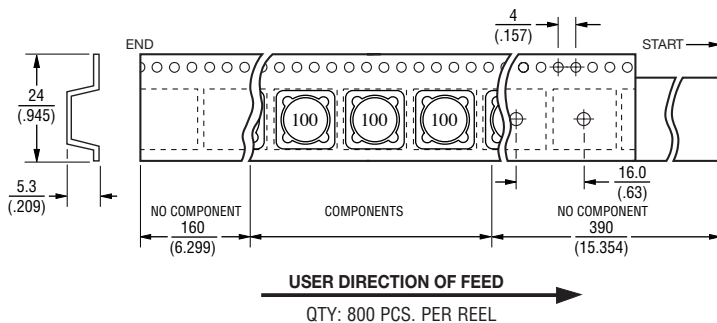
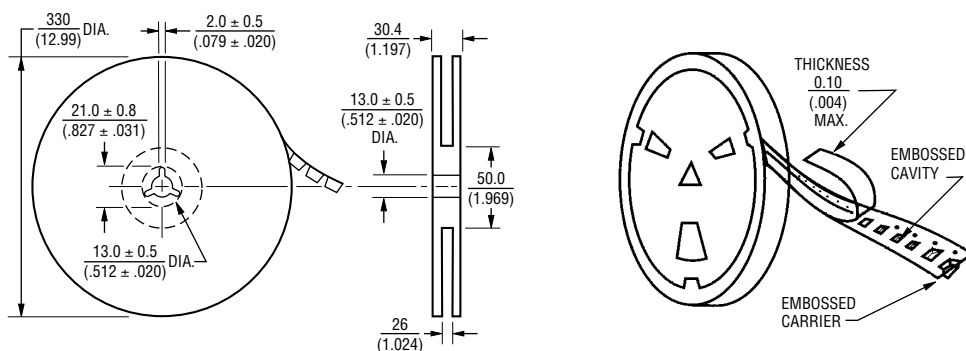

DIMENSIONS:  $\frac{\text{MM}}{\text{(INCHES)}}$

REV. 06/09

Specifications are subject to change without notice.

Customers should verify actual device performance in their specific applications.

\*RoHS COMPLIANT

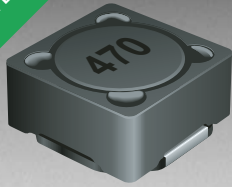

**BOURNS®**

## Features

- Available in E12 values
- Inductance as low as 1.0  $\mu\text{H}$
- Current rating to 9.4 amps
- Lead free
- RoHS compliant\*

## Applications

- Input/output of DC/DC converters
- Power supplies for:
  - Portable communication equipment
  - Camcorders
  - LCD TVs
  - Car radios

# SRR1260 Series - Shielded SMD Power Inductors

## Electrical Specifications

Bourns Part No.	Inductance 100 kHz		Q Typ.	Test Frequency (MHz)	SRF Typ. (MHz)	RDC Max. (m $\Omega$ )	I rms Max. (A)	I sat Typ. (A)
	( $\mu\text{H}$ )	Tol. %						
SRR1260-1R0Y	1.0	$\pm 30$	26	7.96	100.00	7.8	9.40	10.00
SRR1260-1R2Y	1.2	$\pm 30$	18	7.96	91.10	8.0	9.20	9.80
SRR1260-1R5Y	1.5	$\pm 30$	24	7.96	86.00	9.5	8.80	9.90
SRR1260-2R2Y	2.2	$\pm 30$	22	7.96	70.00	10.5	8.20	8.50
SRR1260-2R4Y	2.4	$\pm 30$	18	7.96	63.80	11.5	7.80	8.00
SRR1260-3R3Y	3.3	$\pm 30$	20	7.96	40.00	12.0	7.60	7.80
SRR1260-3R5Y	3.5	$\pm 30$	22	7.96	37.60	13.0	7.50	7.60
SRR1260-4R7Y	4.7	$\pm 30$	19	7.96	36.70	15.5	6.80	7.00
SRR1260-5R6Y	5.6	$\pm 30$	19	7.96	33.00	16.2	6.70	6.90
SRR1260-6R1Y	6.1	$\pm 30$	21	7.96	29.80	17.0	6.60	6.80
SRR1260-6R8Y	6.8	$\pm 30$	20	7.96	28.20	18.0	6.30	6.50
SRR1260-7R6Y	7.6	$\pm 30$	16	7.96	27.90	19.0	6.00	6.20
SRR1260-8R2Y	8.2	$\pm 30$	18	7.96	24.00	19.5	5.70	5.80
SRR1260-100M	10.0	$\pm 20$	32	2.52	21.00	20.0	5.50	5.50
SRR1260-120M	12.0	$\pm 20$	27	2.52	19.40	23.0	5.20	5.00
SRR1260-150M	15.0	$\pm 20$	25	2.52	17.60	27.0	5.00	4.60
SRR1260-180M	18.0	$\pm 20$	28	2.52	15.50	36.0	4.20	3.90
SRR1260-220M	22.0	$\pm 20$	29	2.52	13.40	43.0	4.00	3.70
SRR1260-270M	27.0	$\pm 20$	26	2.52	12.70	45.0	3.60	3.30
SRR1260-330M	33.0	$\pm 20$	27	2.52	9.97	60.0	3.00	2.80
SRR1260-390M	39.0	$\pm 20$	22	2.52	10.40	70.0	2.80	2.70
SRR1260-470M	47.0	$\pm 20$	22	2.52	7.63	86.0	2.60	2.50
SRR1260-560M	56.0	$\pm 20$	24	2.52	7.92	100.0	2.30	2.20
SRR1260-680M	68.0	$\pm 20$	22	2.52	7.43	110.0	2.10	2.10
SRR1260-820M	82.0	$\pm 20$	25	2.52	6.85	145.0	1.95	1.90
SRR1260-101M	100.0	$\pm 20$	26	0.796	6.07	180.0	1.70	1.70
SRR1260-121K	120.0	$\pm 10$	26	0.796	5.50	210.0	1.65	1.65
SRR1260-151K	150.0	$\pm 10$	20	0.796	5.00	260.0	1.55	1.55
SRR1260-181K	180.0	$\pm 10$	26	0.796	4.50	320.0	1.40	1.40
SRR1260-221K	220.0	$\pm 10$	22	0.796	4.20	380.0	1.38	1.30
SRR1260-271K	270.0	$\pm 10$	20	0.796	3.60	450.0	1.30	1.20
SRR1260-331K	330.0	$\pm 10$	22	0.796	3.20	580.0	1.15	1.10
SRR1260-391K	390.0	$\pm 10$	20	0.796	2.80	700.0	1.08	1.00
SRR1260-471K	470.0	$\pm 10$	18	0.796	2.60	820.0	0.95	0.90
SRR1260-561K	560.0	$\pm 10$	22	0.796	2.40	1000.0	0.88	0.80
SRR1260-681K	680.0	$\pm 10$	18	0.796	2.20	1150.0	0.80	0.75
SRR1260-821K	820.0	$\pm 10$	20	0.796	2.00	1500.0	0.73	0.63
SRR1260-102K	1000.0	$\pm 10$	30	0.252	1.80	1700.0	0.68	0.60

## General Specifications

Test Voltage.....0.1 V  
 Reflow Soldering ...230 °C, 50 sec. max.  
 Operating Temperature -40 °C to +125 °C  
 (Temperature rise included)  
 Storage Temperature...-40 °C to +125 °C  
 Resistance to Soldering Heat  
 .....260 °C for 10 sec.

## Materials

Core .....Ferrite DR and RI  
 Wire .....Enameled copper wire 130  
 Terminal.....Cu/Ni/Sn  
 Rated Current  
 .....Ind. drop 25 % typ. at Isat  
 Temperature Rise .....40 °C max.  
 at rated I rms  
 Packaging .....600 pcs. per reel

## Product Dimensions

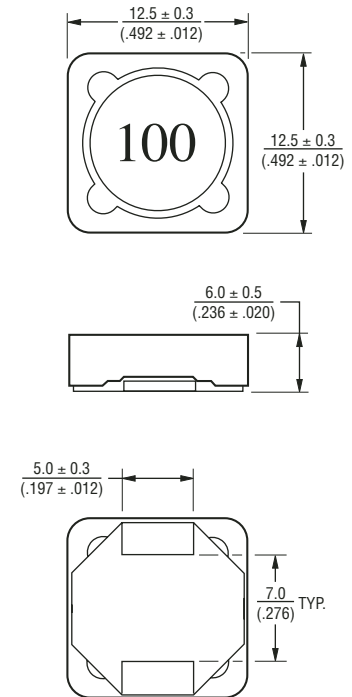

DIMENSIONS:  $\frac{\text{MM}}{\text{(INCHES)}}$

## Electrical Schematic

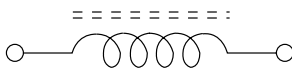

## Recommended Layout

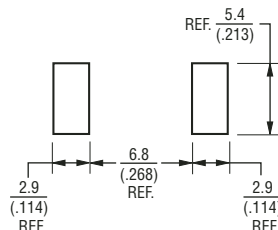

\*RoHS Directive 2002/95/EC Jan 27 2003 including Annex  
 Specifications are subject to change without notice.  
 Customers should verify actual device performance in their specific applications.

# SRR1260 Series - Shielded SMD Power Inductors

**BOURNS®**

## Packaging Specifications

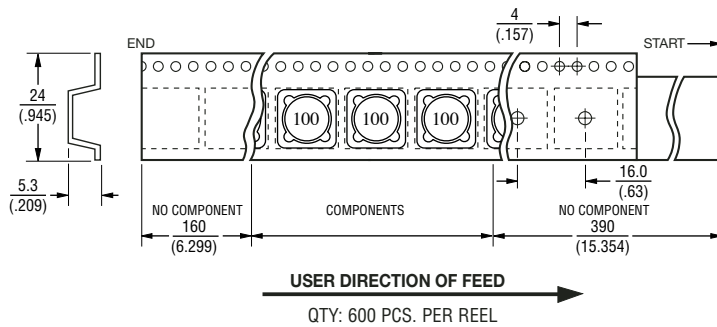
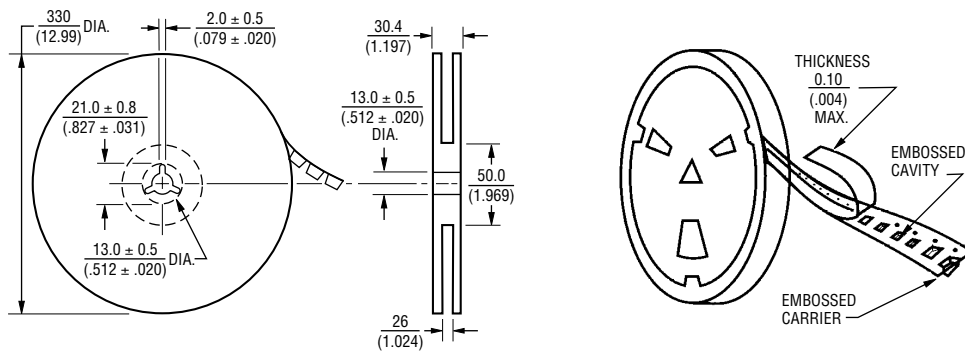

DIMENSIONS:  $\frac{\text{MM}}{\text{(INCHES)}}$

REV. 01/07

Specifications are subject to change without notice.  
Customers should verify actual device performance in their specific applications.

\*RoHS COMPLIANT

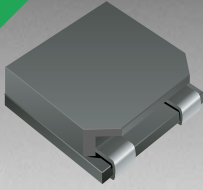

**BOURNS®**

**Features**

- Low height of only 5.0 mm
- Inductance as low as 0.9  $\mu\text{H}$
- High current up to 20 amps
- RoHS compliant\*

**Applications**

- Input/output of DC/DC converters
- Power supplies for:
  - Portable communication equipment
  - Camcorders
  - LCD TVs
  - Car radios

**SRR1305 Series - SMD Shielded Power Inductors**

**Electrical Specifications**

Bourns Part No.	Inductance 100 kHz			SRF Min. (MHz)	RDC (m $\Omega$ )	I rms (L1) Max. (A)	I sat Typ. (A)
	L0 ( $\mu\text{H}$ )	L1 ( $\mu\text{H}$ )	Tol. %				
SRR1305-R90ZL	0.9	0.75	$\pm 25$	95	2.5	20.0	22.0
SRR1305-1R4ZL	1.4	1.25	$\pm 25$	70	3.4	16.0	18.0
SRR1305-2R0ZL	2.0	1.80	$\pm 25$	60	4.6	13.0	15.0
SRR1305-2R7ZL	2.7	2.50	$\pm 25$	50	9.5	6.0	10.0

**General Specifications**

Test Voltage.....0.1 V  
 Reflow Soldering ...230 °C, 50 sec. max.  
 Operating Temperature -40 °C to +125 °C  
 (Temperature rise included)  
 Storage Temperature...-40 °C to +125 °C  
 Resistance to Soldering Heat  
 .....260 °C for 5 sec.

**Materials**

Core .....Ferrite ER and SB  
 Wire .....Ultra-fine rectangular enameled copper  
 Terminal .....Cu/Sn  
 Adhesive .....Epoxy resin  
 Rated Current  
 .....Ind. drop 20 % max. at (L1) Isat  
 Temperature Rise  
 .....45 °C max. at rated I rms  
 Packaging.....600 pcs. per reel

**Product Dimensions**

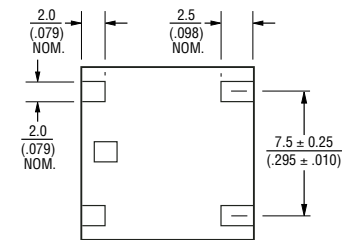
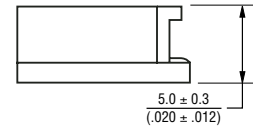
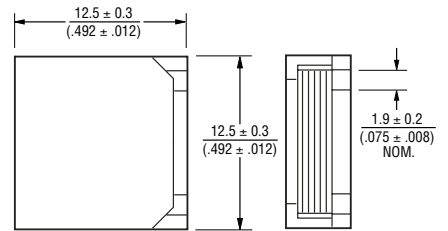

DIMENSIONS:  $\frac{\text{MM}}{\text{(INCHES)}}$

**Inductance vs. DC Superposition Characteristics**

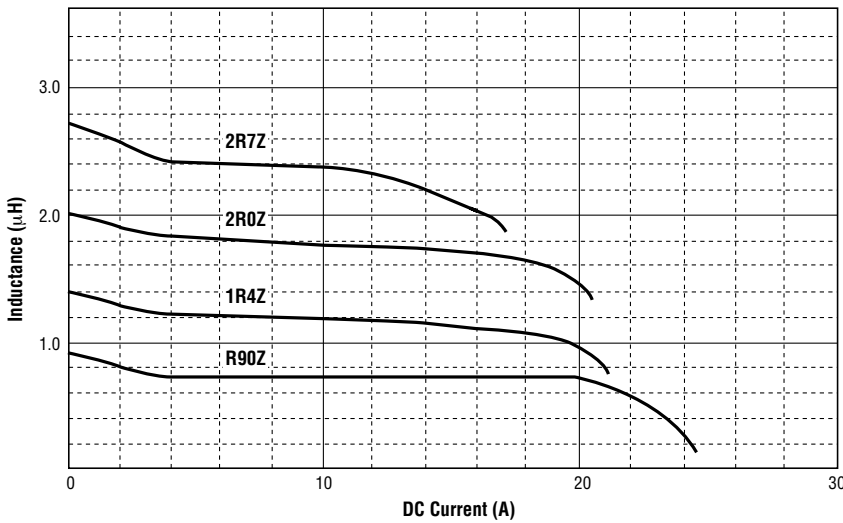

**Recommended Layout**

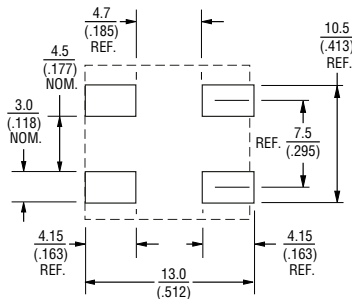

**Electrical Schematic**

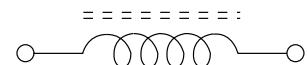

\*RoHS Directive 2002/95/EC Jan 27 2003 including Annex  
 Specifications are subject to change without notice.  
 Customers should verify actual device performance in their specific applications.



# SRR1305 Series - SMD Shielded Power Inductors

**BOURNS®**

## Packaging Specifications

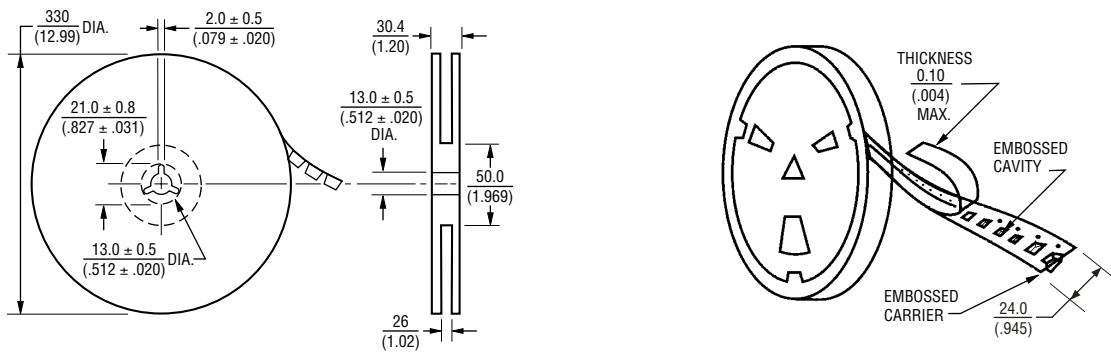

QTY: 600 PCS. PER REEL

DIMENSIONS:  $\frac{\text{MM}}{\text{(INCHES)}}$

\*RoHS COMPLIANT

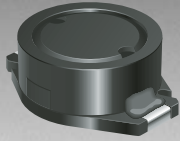

**BOURNS®**

## Features

- Available in E12 series
- Unit height of 6.8 mm
- Current up to 8 A Isat
- Lead free
- RoHS compliant\*

## Applications

- Input/output of DC/DC converters
- Power supplies for:
  - Portable communication equipment
  - Camcorders
  - LCD TVs
  - Car radios

# SRR1806 Series - Shielded Power Inductors

## Electrical Specifications

Bourns Part No.	Inductance 100 kHz		Q Ref.	Test Frequency (MHz)	SRF Typ. (MHz)	RDC -20% (Ω)	I rms Max. (A)	I sat Typ. (A)
	(μH)	Tol. %						
SRR1806-100M	10.0	± 20	56	2.52	19.0	0.033	4.00	8.20
SRR1806-150M	15.0	± 20	53	2.52	17.5	0.039	3.60	7.20
SRR1806-220M	22.0	± 20	51	2.52	16.0	0.053	3.00	6.20
SRR1806-330M	33.0	± 20	44	2.52	10.0	0.083	2.50	5.00
SRR1806-470M	47.0	± 20	40	2.52	8.0	0.110	2.00	4.20
SRR1806-680M	68.0	± 20	37	2.52	6.0	0.170	1.60	3.40
SRR1806-101M	100.0	± 20	40	0.796	4.6	0.270	1.30	2.60
SRR1806-151M	150.0	± 20	39	0.796	4.3	0.400	1.05	2.30
SRR1806-221M	220.0	± 20	29	0.796	3.5	0.510	1.00	1.90
SRR1806-331M	330.0	± 20	30	0.796	3.0	0.790	0.80	1.40
SRR1806-471M	470.0	± 20	27	0.796	2.4	1.000	0.64	1.30
SRR1806-681M	680.0	± 20	19	0.796	2.1	1.470	0.54	1.10
SRR1806-102M	1000.0	± 20	46	0.796	1.5	2.160	0.45	0.90

## General Specifications

Test Voltage.....0.1 V  
 Reflow soldering.....250 °C; 10 sec max.  
 (In compliance with JEDEC, J-STD-020C, Table 4-2)  
 Operating Temperature ..-40 °C to +125 °C  
 (Temperature rise included)  
 Storage Temperature...-45 °C to +125 °C  
 Resistance to Soldering Heat  
 .....250 °C, 10 sec. max.

## Materials

Core.....Ferrite core  
 Wire.....Enamelled copper  
 Base .....LCP E4008  
 Terminal .....Cu/Ni/Sn  
 Rated Current Ind. drop 10 % typ. at Isat  
 Temperature Rise  
 .....40 °C max. at rated Irms  
 Packaging.....250 pcs. per reel

## Soldering Profile

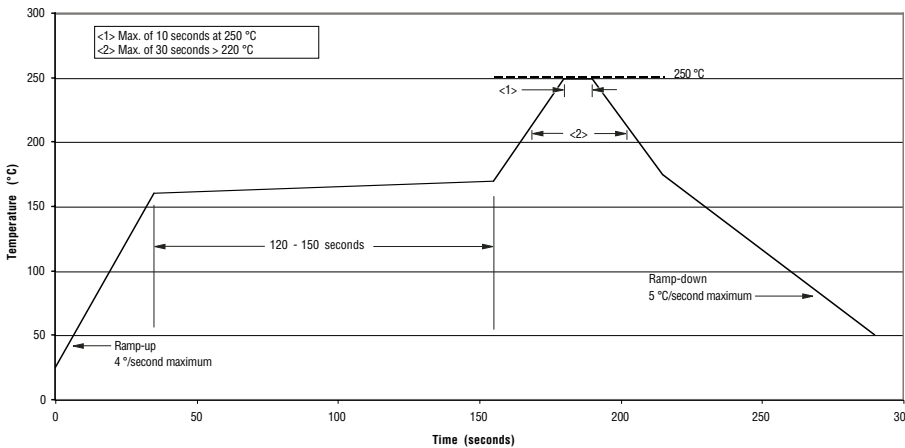

## Product Dimensions

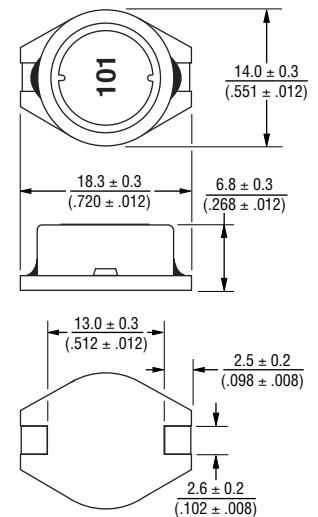

## Recommended Layout

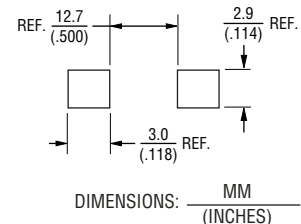

## Electrical Schematic

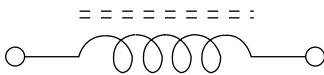

\*RoHS Directive 2002/95/EC Jan 27 2003 including Annex  
 Specifications are subject to change without notice.  
 Customers should verify actual device performance in their specific applications.

# SRR1806 Series - Shielded Power Inductors

**BOURNS®**

## Packaging Specifications

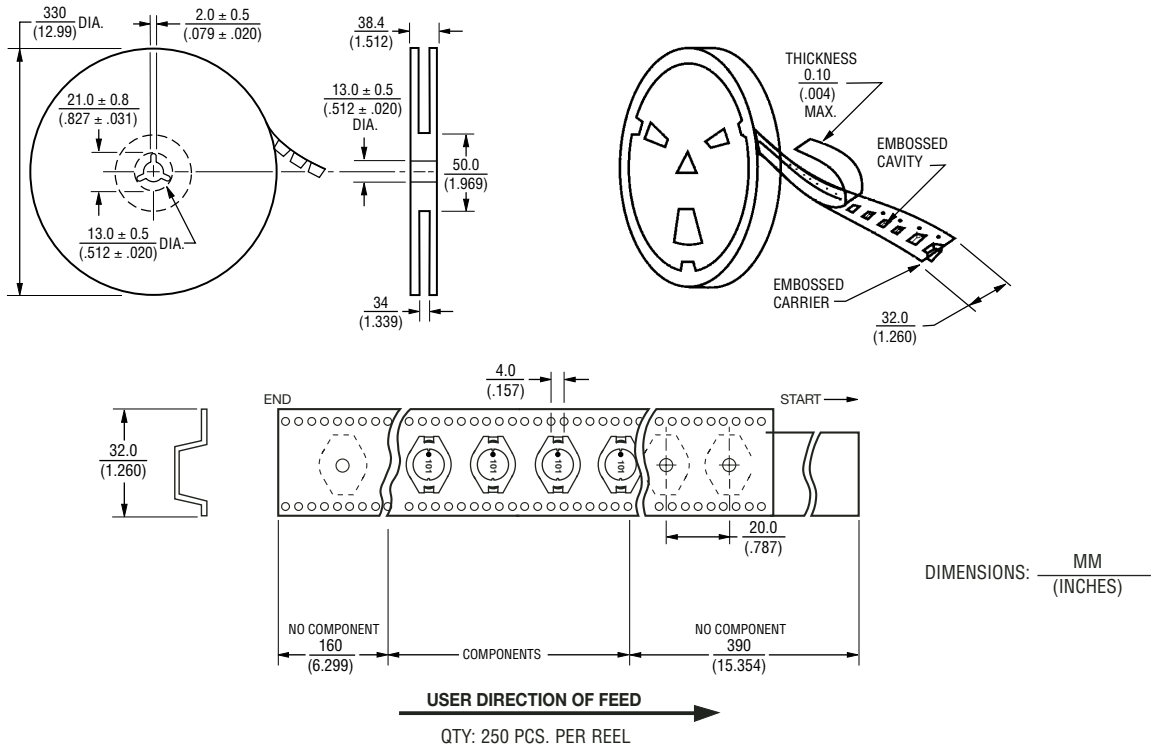

REV. 02/06

Specifications are subject to change without notice.  
Customers should verify actual device performance in their specific applications.

\*RoHS COMPLIANT

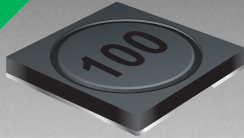

**BOURNS®**

## Features

- Available in E6 values
- Mounting height of only 1.15 mm
- Inductance value to 1.5 µH
- RoHS compliant\*

## Applications

- Input/output of DC/DC converters
- Power supplies for:
  - Portable communication equipment
  - Camcorders
  - LCD TVs
  - Car radios

# SRR3011 Series - Shielded SMD Power Inductors

### Electrical Specifications

Bourns Part No.	Inductance 100 kHz		Q Typ.	Test Frequency (MHz)	SRF Min. (MHz)	RDC Max. (Ω)	I rms Max. (A)	I sat Typ. (A)
	(µH)	Tol. %						
SRR3011-1R5YL	1.50	± 30	11	7.96	124	0.055	1.60	1.30
SRR3011-2R5YL	2.50	± 30	7	7.96	112	0.085	1.20	1.00
SRR3011-3R3YL	3.30	± 30	8	7.96	101	0.090	1.00	0.85
SRR3011-4R7YL	4.70	± 30	9	7.96	69	0.125	0.90	0.75
SRR3011-6R8YL	6.80	± 30	10	7.96	49	0.210	0.72	0.62
SRR3011-100YL	10.0	± 30	18	2.52	42	0.280	0.65	0.50
SRR3011-150YL	15.0	± 30	16	2.52	37	0.420	0.48	0.38
SRR3011-220YL	22.0	± 30	11	2.52	31	0.680	0.38	0.32
SRR3011-330YL	33.0	± 30	14	2.52	25	0.860	0.32	0.27
SRR3011-470YL	47.0	± 30	16	2.52	18	1.800	0.27	0.23
SRR3011-680YL	68.0	± 30	14	2.52	15	2.250	0.22	0.18
SRR3011-101YL	100.0	± 30	39	0.796	13	3.600	0.18	0.15

### General Specifications

Test Voltage.....0.1 V  
 Reflow Soldering ...230 °C, 50 sec. max.  
 Operating Temperature -40 °C to +125 °C  
 (Temperature rise included)  
 Storage Temperature...-40 °C to +125 °C  
 Resistance to Soldering Heat  
 .....260 °C for 10 sec.

### Materials

Core .....Ferrite DR and RI  
 Wire .....Enameled copper wire 130  
 Terminal.....Ag/Ni/Sn  
 Rated Current  
 .....Ind. drop 35 % typ. at Isat  
 Temperature Rise .....30 °C max.  
 at rated I<sub>rms</sub>  
 Packaging .....1200 pcs. per reel

### Electrical Schematic

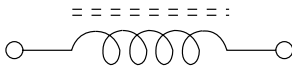

### Recommended Layout

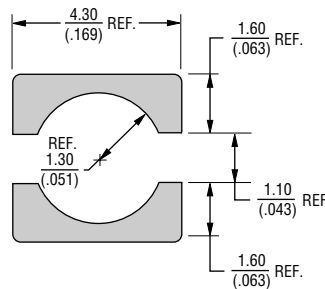

### Product Dimensions

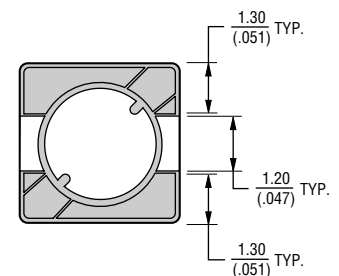
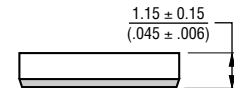
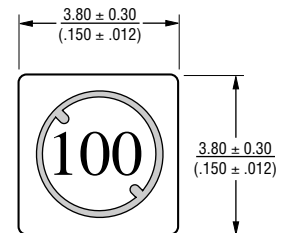

DIMENSIONS:  $\frac{\text{MM}}{\text{(INCHES)}}$

\*RoHS Directive 2002/95/EC Jan 27 2003 including Annex  
 Specifications are subject to change without notice.  
 Customers should verify actual device performance in their specific applications.

# SRR3011 Series - Shielded SMD Power Inductors

**BOURNS®**

## Packaging Specifications

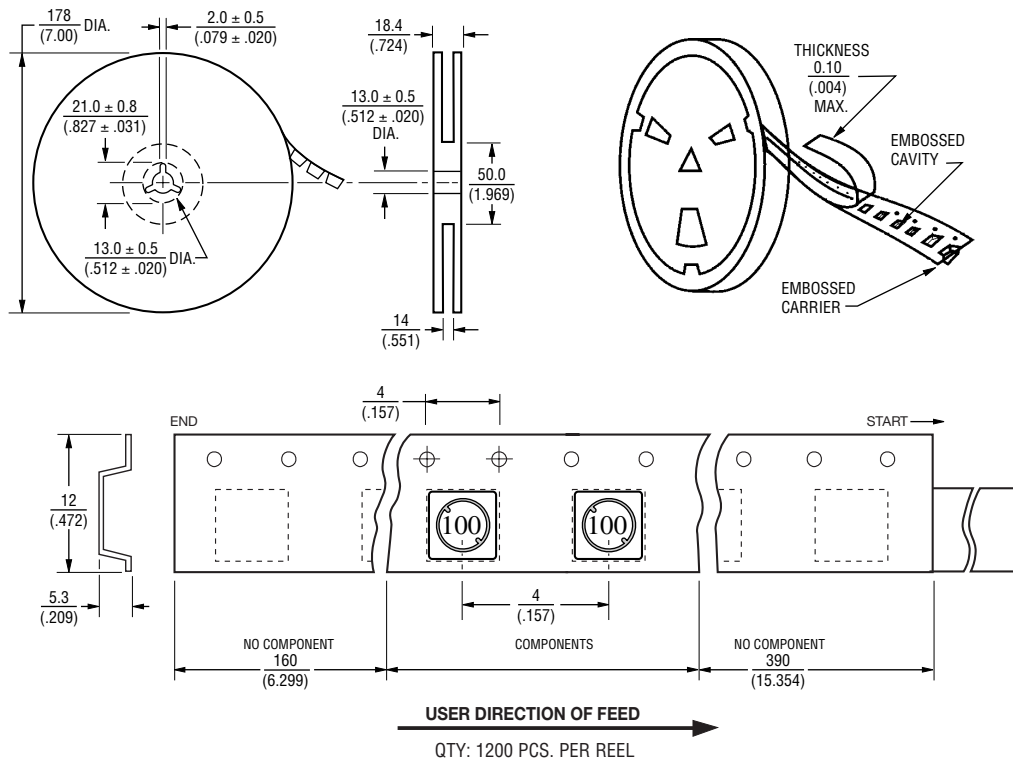

DIMENSIONS:  $\frac{\text{MM}}{\text{(INCHES)}}$

REV. 07/10

Specifications are subject to change without notice.  
Customers should verify actual device performance in their specific applications.

RoHS COMPLIANT

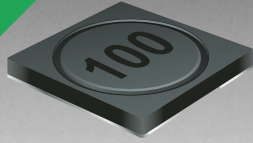

**BOURNS®**

### Features

- Available in E6 values
- Mounting height of only 1.15 mm
- Inductance value to 0.47  $\mu$ H
- RoHS compliant\*

### Applications

- Input/output of DC/DC converters
- Power supplies for:
  - Portable communication equipment
  - Camcorders
  - LCD TVs
  - Car radios

## SRR4011 Series - Shielded SMD Power Inductors

### Electrical Specifications

Bourns Part No.	Inductance 100 kHz		Q Typ.	Test Frequency (MHz)	SRF Min. (MHz)	RDC Max. ( $\Omega$ )	I rms Max. (A)	I sat Typ. (A)
	( $\mu$ H)	Tol. %						
SRR4011-R47YL	0.47	$\pm 30$	7	25.2	221	0.030	3.20	3.80
SRR4011-1R2YL	1.20	$\pm 30$	10	7.96	133	0.048	2.70	2.50
SRR4011-1R5YL	1.50	$\pm 30$	11	7.96	121	0.056	2.30	2.10
SRR4011-2R2YL	2.20	$\pm 30$	11	7.96	92	0.075	2.00	1.80
SRR4011-3R3YL	3.30	$\pm 30$	10	7.96	67	0.110	1.60	1.40
SRR4011-4R7YL	4.70	$\pm 30$	13	7.96	61	0.165	1.35	1.20
SRR4011-6R2YL	6.20	$\pm 30$	7	7.96	51	0.195	1.20	1.00
SRR4011-8R2YL	8.20	$\pm 30$	8	7.96	39	0.215	1.10	0.92
SRR4011-100YL	10.00	$\pm 30$	14	2.52	41	0.240	1.00	0.83
SRR4011-150YL	15.00	$\pm 30$	11	2.52	33	0.400	0.90	0.70
SRR4011-220YL	22.00	$\pm 30$	13	2.52	23	0.580	0.60	0.57
SRR4011-330YL	33.00	$\pm 30$	15	2.52	20	0.860	0.55	0.47
SRR4011-470YL	47.00	$\pm 30$	10	2.52	18	1.250	0.48	0.40
SRR4011-680YL	68.00	$\pm 30$	12	2.52	14	1.800	0.35	0.32
SRR4011-820YL	82.00	$\pm 30$	13	2.52	11	2.200	0.33	0.30
SRR4011-101YL	100.00	$\pm 30$	18	0.796	11	2.400	0.31	0.27
SRR4011-151YL	150.00	$\pm 30$	39	0.796	8	3.800	0.25	0.22

### General Specifications

Test Voltage.....0.1 V  
 Reflow Soldering ...230 °C, 50 sec. max.  
 Operating Temperature -40 °C to +125 °C  
 (Temperature rise included)  
 Storage Temperature...-40 °C to +125 °C  
 Resistance to Soldering Heat  
 .....260 °C for 10 sec.

### Materials

Core .....Ferrite DR and RI  
 Wire .....Enameled copper wire 130  
 Terminal.....Ag/Ni/Sn  
 Rated Current  
 .....Ind. drop 30 % typ. at Isat  
 Temperature Rise .....40 °C max.  
 at rated I rms  
 Packaging .....1200 pcs. per reel

### Product Dimensions

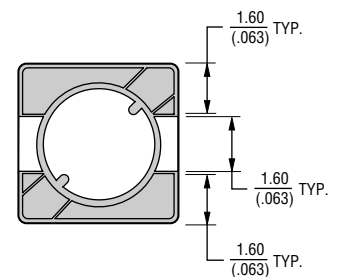
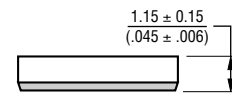
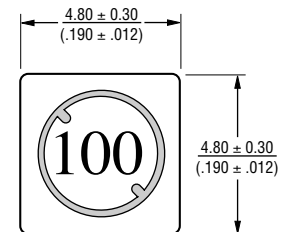

DIMENSIONS:  $\frac{\text{MM}}{\text{(INCHES)}}$

### Electrical Schematic

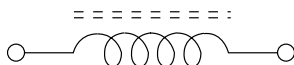

### Recommended Layout

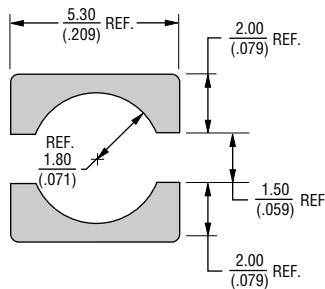

\*RoHS Directive 2002/95/EC Jan 27 2003 including Annex  
 Specifications are subject to change without notice.  
 Customers should verify actual device performance in their specific applications.

# SRR4011 Series - Shielded SMD Power Inductors

**BOURNS®**

## Packaging Specifications

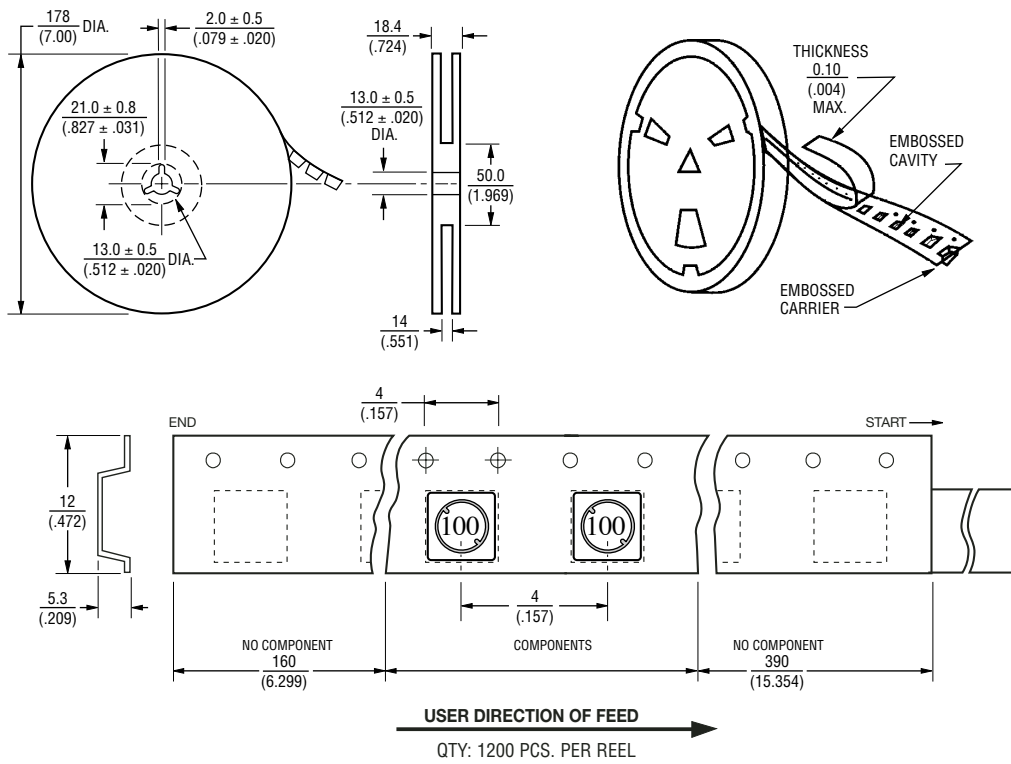

DIMENSIONS:  $\frac{\text{MM}}{\text{(INCHES)}}$

REV. 05/05

Specifications are subject to change without notice.  
Customers should verify actual device performance in their specific applications.

\*RoHS COMPLIANT

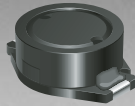

**BOURNS®**

## Features

- Available in E12 series
- Unit height of 3 mm
- Current up to 3 A
- RoHS compliant\*

## Applications

- Input/output of DC/DC converters
- Power supplies for:
  - Portable communication equipment
  - Camcorders
  - LCD TVs
  - Car radios

# SRR6603 Series - Shielded Power Inductors

### Electrical Specifications

Bourns Part No.	Inductance 100kHz		Q Ref.	Test Frequency (kHz) Q	SRF Nom. (MHz)	RDC Max. (Ω)	IDC Max. (A)
	(μH)	Tol. %					
SRR6603-1R0ML	1.0	± 20	30	200	250	0.040	3.00
SRR6603-1R5ML	1.5	± 20	30	200	125	0.045	2.80
SRR6603-2R2ML	2.2	± 20	40	200	120	0.050	1.80
SRR6603-3R3ML	3.3	± 20	40	200	120	0.055	1.60
SRR6603-4R7ML	4.7	± 20	40	200	105	0.060	1.40
SRR6603-6R8ML	6.8	± 20	40	200	50	0.065	1.20
SRR6603-100ML	10.0	± 20	40	200	38	0.075	1.00
SRR6603-150ML	15.0	± 20	40	100	33	0.090	0.80
SRR6603-220ML	22.0	± 20	40	100	25	0.110	0.70
SRR6603-330ML	33.0	± 20	40	100	20	0.190	0.60
SRR6603-470ML	47.0	± 20	40	100	20	0.230	0.50
SRR6603-680ML	68.0	± 20	40	100	15	0.290	0.40
SRR6603-101ML	100.0	± 20	40	100	10	0.480	0.30
SRR6603-151ML	150.0	± 20	40	100	9	0.590	0.26
SRR6603-221ML	220.0	± 20	40	100	6	0.770	0.22
SRR6603-331ML	330.0	± 20	40	100	5	1.400	0.20
SRR6603-471ML	470.0	± 20	40	100	4	1.800	0.19
SRR6603-681ML	680.0	± 20	40	100	3	2.200	0.18
SRR6603-102ML	1000.0	± 20	40	100	2	3.400	0.15
SRR6603-152ML	1500.0	± 20	50	100	2	4.200	0.12
SRR6603-222ML	2200.0	± 20	50	100	2	8.500	0.10
SRR6603-332ML	3300.0	± 20	50	100	1	11.000	0.08
SRR6603-472ML	4700.0	± 20	50	100	1	13.900	0.06
SRR6603-682ML	6800.0	± 20	50	100	1	25.000	0.04
SRR6603-103ML	10000.0	± 20	50	100	0.8	32.800	0.02

### Electrical Schematic

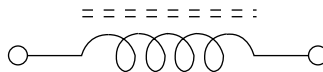

### General Specifications

Test Voltage.....0.1 V  
 Reflow soldering.....250 °C; 10 sec max.  
 (In compliance with JEDEC, J-STD-020C, Table 4-2)  
 Operating Temperature...-55 °C to +125 °C  
 (Temperature rise included)  
 Storage Temperature...-55 °C to +125 °C  
 Resistance to Soldering Heat  
 .....250 °C, 10 sec. max.

### Materials

Core.....Ferrite DR & RI core  
 Wire.....Enameled copper  
 Base .....Ceramic  
 Terminal.....Cu/Ni/Au  
 Temperature Rise  
 .....30 °C max. at rated Irms  
 Packaging.....600 pcs. per reel

### Product Dimensions

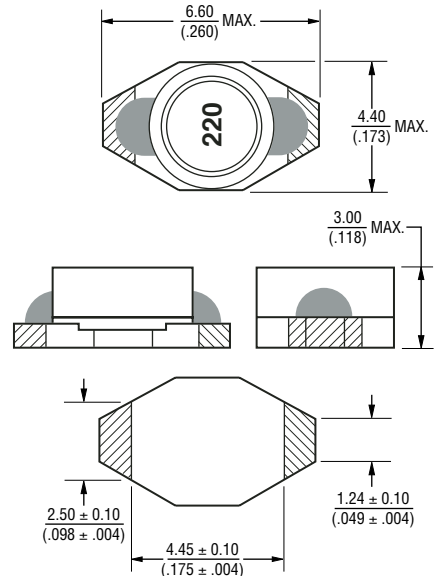

### Recommended Layout

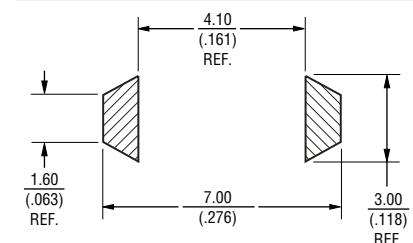

\*RoHS Directive 2002/95/EC Jan 27 2003 including Annex  
 Specifications are subject to change without notice.  
 Customers should verify actual device performance in their specific applications.



# SRR6603 Series - Shielded Power Inductors

**BOURNS®**

## Soldering Profile

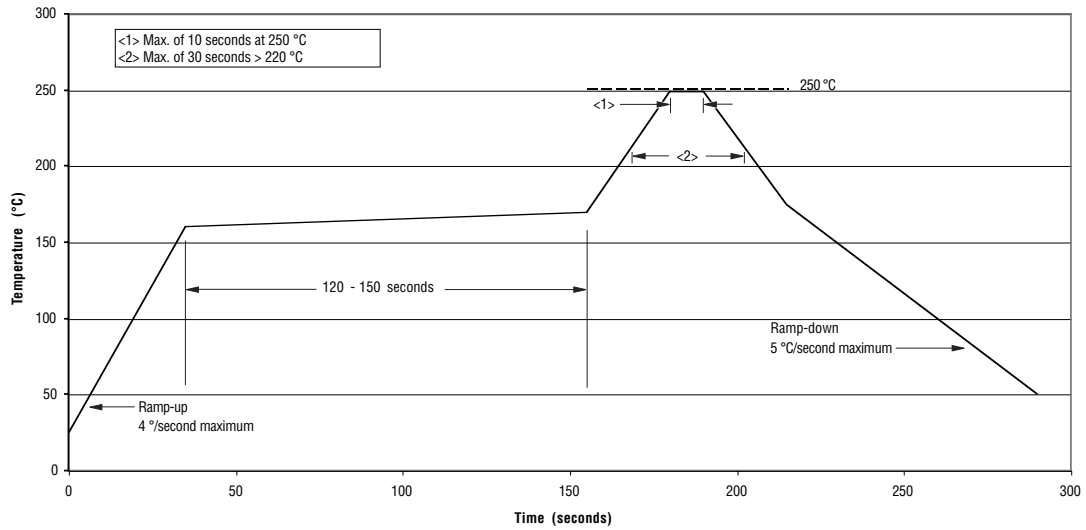

## Packaging Specifications

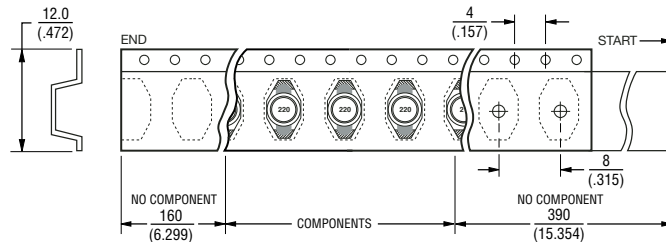
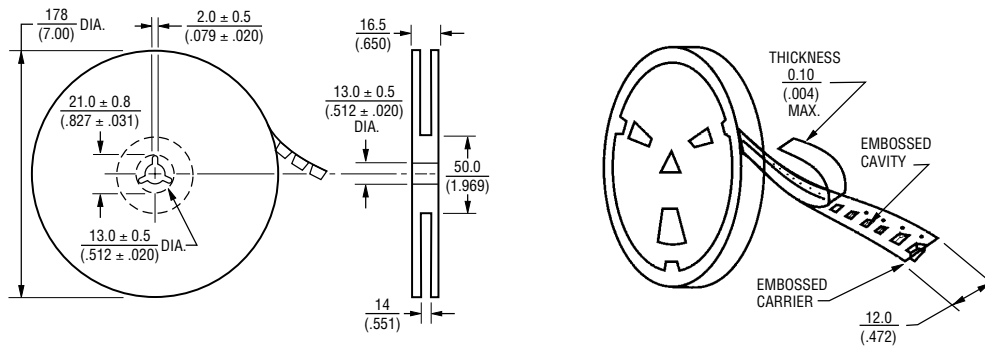

DIMENSIONS: MM  
(INCHES)

QTY: 600 PCS. PER REEL

REV. 02/08

Specifications are subject to change without notice.  
Customers should verify actual device performance in their specific applications.

\*RoHS COMPLIANT



**BOURNS®**

### Features

- Available in E6 values
- Inductance value to 1000 µH
- Lead free
- RoHS compliant\*

### Applications

- Input/output of DC/DC converters
- Power supplies for:
  - Portable communication equipment
  - Camcorders
  - LCD TVs
  - Car radios

## SRR7032 Series - Shielded SMD Power Inductors

### Electrical Specifications

Bourns Part No.	Inductance 100 kHz		Q Typ.	Test Frequency (MHz)	SRF Typ. (MHz)	RDC Max. (Ω)	I rms Max. (A)	I sat Typ. (A)
	(µH)	Tol. %						
SRR7032-2R2M	2.2	± 20	12	7.96	70	0.022	2.65	2.60
SRR7032-3R3M	3.3	± 20	16	7.96	55	0.027	2.40	2.20
SRR7032-4R7M	4.7	± 20	16	7.96	43	0.042	2.00	2.00
SRR7032-6R8M	6.8	± 20	17	7.96	37	0.054	1.60	1.80
SRR7032-100M	10.0	± 20	25	2.52	35	0.068	1.40	1.60
SRR7032-150M	15.0	± 20	22	2.52	32	0.095	1.10	1.20
SRR7032-220M	22.0	± 20	20	2.52	29	0.135	0.96	1.05
SRR7032-330M	33.0	± 20	23	2.52	20	0.200	0.76	0.86
SRR7032-470M	47.0	± 20	26	2.52	18	0.280	0.67	0.77
SRR7032-680M	68.0	± 20	22	2.52	16	0.380	0.60	0.70
SRR7032-101M	100.0	± 20	28	0.796	12	0.540	0.45	0.50
SRR7032-151M	150.0	± 20	35	0.796	10	0.800	0.37	0.38
SRR7032-221M	220.0	± 20	47	0.796	7.5	1.300	0.30	0.32
SRR7032-331M	330.0	± 20	46	0.796	6.1	1.900	0.22	0.24
SRR7032-471M	470.0	± 20	34	0.796	5.1	2.400	0.20	0.20
SRR7032-681M	680.0	± 20	58	0.796	3.8	3.750	0.16	0.15
SRR7032-102M	1000.0	± 20	120	0.252	3.1	5.400	0.15	0.14

### General Specifications

Test Voltage.....0.5 V  
 Reflow Soldering ...230 °C, 50 sec. max.  
 Operating Temperature -40 °C to +125 °C  
 (Temperature rise included)  
 Storage Temperature...-40 °C to +125 °C  
 Resistance to Soldering Heat  
 .....260 °C for 10 sec.

### Materials

Core .....Ferrite DR and RI  
 Wire .....Enameled copper wire 130  
 Terminal.....Cu/Ni/Sn  
 Rated Current  
 .....Ind. drop 10 % typ. at Isat  
 Temperature Rise .....30 °C max.  
 at rated I<sub>rms</sub>  
 Packaging .....1500 pcs. per reel

### Product Dimensions

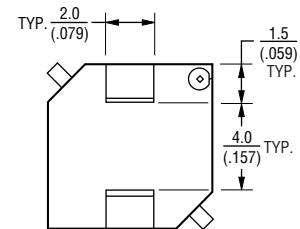
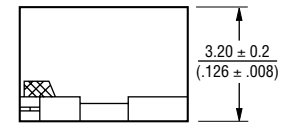
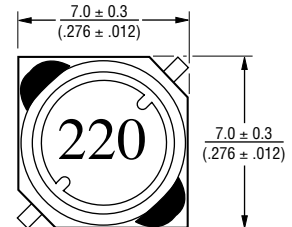

DIMENSIONS:  $\frac{\text{MM}}{\text{(INCHES)}}$

### Electrical Schematic

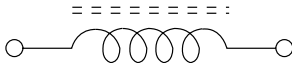

### Recommended Layout

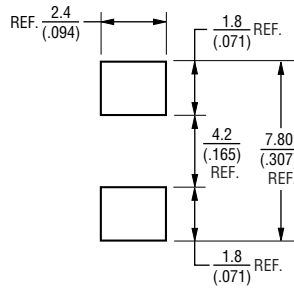

\*RoHS Directive 2002/95/EC Jan 27 2003 including Annex  
 Specifications are subject to change without notice.  
 Customers should verify actual device performance in their specific applications.

# SRR7032 Series - Shielded SMD Power Inductors

**BOURNS®**

## Packaging Specifications

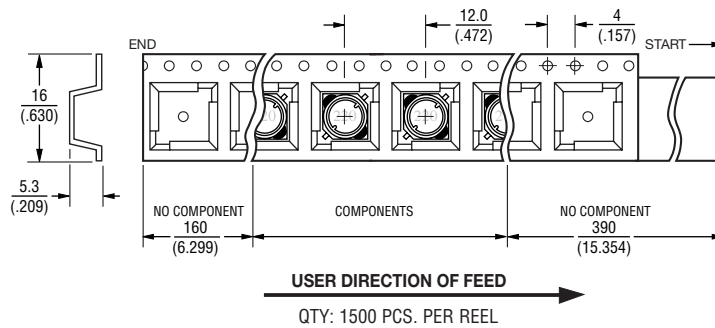
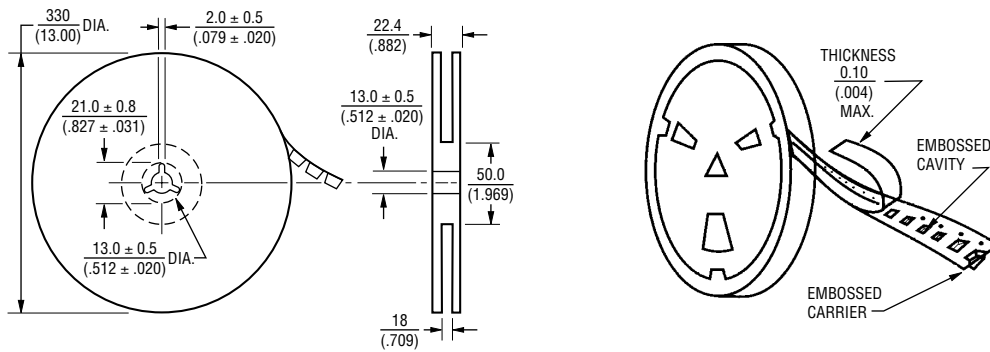

DIMENSIONS:  $\frac{\text{MM}}{\text{(INCHES)}}$

REV. 07/10

Specifications are subject to change without notice.  
Customers should verify actual device performance in their specific applications.

\*RoHS COMPLIANT

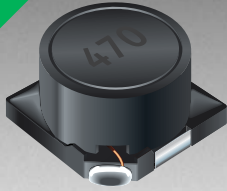

**BOURNS®**

## Features

- Available in E6 values
- Current rating to 3.50 amps
- Lead free
- RoHS compliant\*

## Applications

- Input/output of DC/DC converters
- Power supplies for:
  - Portable communication equipment
  - Camcorders
  - LCD TVs
  - Car radios

# SRR7045 Series - Shielded SMD Power Inductors

### Electrical Specifications

Bourns Part No.	Inductance 100 kHz		Q Typ.	Test Frequency (MHz)	SRF Typ. (MHz)	RDC Max. (Ω)	I rms Max. (A)	I sat Typ. (A)
	(μH)	Tol. %						
SRR7045-1R0M	1.0	± 20	10	7.96	60	0.020	3.50	3.20
SRR7045-2R2M	2.2	± 20	10	7.96	60	0.022	2.80	2.50
SRR7045-2R7M	2.7	± 20	10	7.96	60	0.027	2.78	3.10
SRR7045-3R3M	3.3	± 20	10	7.96	43	0.027	2.50	2.20
SRR7045-3R9M	3.9	± 20	10	7.96	40	0.028	2.71	2.43
SRR7045-4R7M	4.7	± 20	10	7.96	35	0.030	2.64	2.20
SRR7045-5R6M	5.6	± 20	10	7.96	33	0.036	2.38	2.00
SRR7045-6R3M	6.3	± 20	10	7.96	30	0.038	2.33	1.85
SRR7045-6R8M	6.8	± 20	10	7.96	28	0.036	2.20	2.00
SRR7045-100M	10	± 20	30	2.52	25	0.042	2.00	1.70
SRR7045-120M	12	±20	27	2.52	23	0.050	1.85	1.40
SRR7045-150M	15	± 20	31	2.52	24	0.062	1.60	1.35
SRR7045-180M	18	±20	29	2.52	21	0.070	1.50	1.15
SRR7045-220M	22	± 20	26	2.52	18	0.082	1.35	1.10
SRR7045-270M	27	±20	25	2.52	18	0.110	1.25	1.00
SRR7045-330M	33	± 20	25	2.52	12	0.115	1.15	0.90
SRR7045-390M	39	±20	26	2.52	13	0.130	1.10	0.80
SRR7045-470M	47	± 20	29	2.52	11	0.150	0.95	0.78
SRR7045-560M	56	±20	21	2.52	11	0.200	0.85	0.65
SRR7045-680M	68	± 20	22	2.52	10	0.210	0.77	0.60
SRR7045-820M	82	± 20	22	2.52	9	0.280	0.70	0.60
SRR7045-101M	100	± 20	40	0.796	8	0.300	0.65	0.50
SRR7045-121M	120	±20	30	0.796	7	0.420	0.60	0.45
SRR7045-151M	150	± 20	51	0.796	7	0.480	0.53	0.41
SRR7045-181M	180	±20	52	0.796	5	0.660	0.475	0.375
SRR7045-221M	220	± 20	44	0.796	5	0.700	0.45	0.36
SRR7045-271M	270	±20	30	0.796	5	0.840	0.40	0.275
SRR7045-331M	330	± 20	65	0.796	4	0.730	0.40	0.25
SRR7045-391M	390	±20	27	0.796	5	1.200	0.35	0.225
SRR7045-471M	470	± 20	80	0.796	3	1.100	0.32	0.22
SRR7045-561M	560	±20	27	0.796	4	1.600	0.30	0.20
SRR7045-681M	680	± 20	65	0.796	3	1.600	0.27	0.20
SRR7045-821M	820	±20	26	0.796	3	2.200	0.25	0.175
SRR7045-102M	1000	± 20	90	0.252	3	2.400	0.25	0.15

### General Specifications

Test Voltage.....0.5 V  
 Reflow Soldering ...230 °C, 50 sec. max.  
 Operating Temperature ..-40 °C to +125 °C  
 (Temperature rise included)  
 Storage Temperature...-40 °C to +125 °C  
 Resistance to Soldering Heat  
 .....260 °C for 10 sec.

### Materials

Core .....Ferrite DR and RI  
 Wire .....Enameled copper wire 130  
 Terminal.....Cu/Ni/Sn  
 Rated Current  
 .....Ind. drop 10 % typ. at Isat  
 (-1R0M through -221M)  
 .....Ind. drop 25 % typ. at Isat  
 (-271M through -102M)  
 Temperature Rise .....30 °C max.  
 at rated I rms  
 Packaging .....1000 pcs. per reel

### Product Dimensions

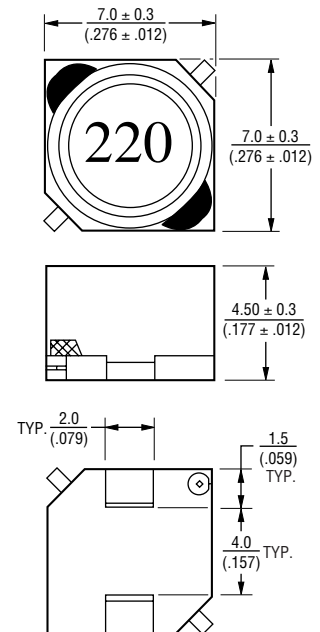

DIMENSIONS:  $\frac{\text{MM}}{\text{(INCHES)}}$

### Electrical Schematic

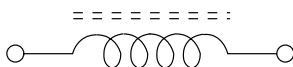

### Recommended Layout

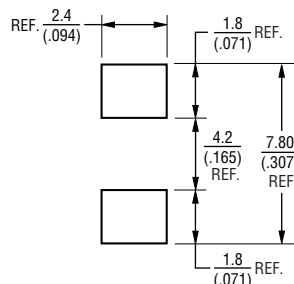

\*RoHS Directive 2002/95/EC Jan 27 2003 including Annex  
 Specifications are subject to change without notice.  
 Customers should verify actual device performance in their specific applications.

# SRR7045 Series - Shielded SMD Power Inductors

**BOURNS®**

## Packaging Specifications

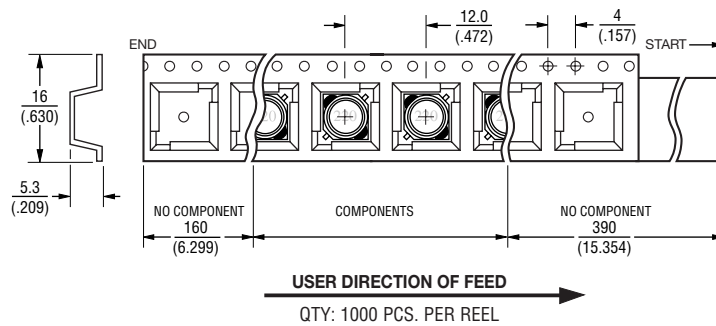
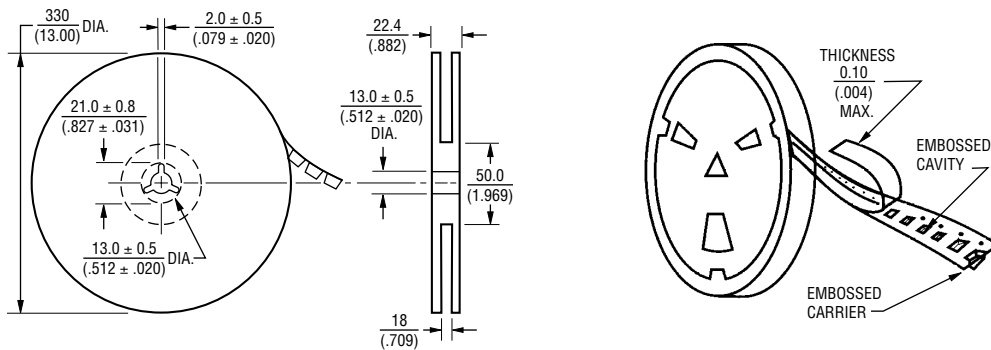

DIMENSIONS:  $\frac{\text{MM}}{\text{(INCHES)}}$

REV. 07/10

Specifications are subject to change without notice.  
Customers should verify actual device performance in their specific applications.

\*RoHS COMPLIANT

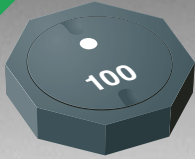

**BOURNS®**

## Features

- Available in E6 series
- Unit height of 2.8 mm
- Current up to 7 A
- Lead free
- RoHS compliant\*

## Applications

- Input/output of DC/DC converters
- Power supplies for:
  - Portable communication equipment
  - Camcorders
  - LCD TVs
  - Car radios

# SRU1028 Series - Shielded SMD Power Inductors

## Electrical Specifications

Bourns Part No.	Inductance 100 KHz		Q Ref.	Test Frequency (MHz)	SRF Min. (MHz)	RDC (mΩ)	I rms Max. (A)	I sat Typ. (A)
	(μH)	Tol. %						
SRU1028-1R0Y	1.0	± 30	14	7.96	100.0	4.9	7.00	8.00
SRU1028-1R5Y	1.5	± 30	12	7.96	80.0	7.3	6.50	6.50
SRU1028-2R2Y	2.2	± 30	12	7.96	65.0	11	5.30	4.80
SRU1028-3R3Y	3.3	± 30	14	7.96	55.0	15	4.60	4.30
SRU1028-4R7Y	4.7	± 30	12	7.96	40.0	16	4.50	3.80
SRU1028-6R8Y	6.8	± 30	12	7.96	30.0	25	3.50	3.00
SRU1028-8R2Y	8.2	± 30	12	7.96	28.0	28	3.30	2.70
SRU1028-100Y	10.0	± 30	20	7.96	25.0	40	2.80	2.40
SRU1028-120Y	12.0	± 30	22	2.52	23.0	70	2.40	2.30
SRU1028-150Y	15.0	± 30	26	2.52	22.0	69	2.00	2.00
SRU1028-220Y	22.0	± 30	26	2.52	16.0	104	1.60	1.40
SRU1028-330Y	33.0	± 30	24	2.52	12.0	139	1.25	1.20
SRU1028-470Y	47.0	± 30	20	2.52	11.0	167	1.30	1.10
SRU1028-560Y	56.0	± 30	22	2.52	10.0	208	1.10	1.00
SRU1028-680Y	68.0	± 30	20	2.52	9.0	232	1.00	0.90
SRU1028-820Y	82.0	± 30	20	2.52	8.0	323	0.90	0.85
SRU1028-101Y	100.0	± 30	20	0.796	7.0	365	0.85	0.80
SRU1028-121Y	120.0	± 30	18	0.796	6.0	428	0.65	0.70
SRU1028-151Y	150.0	± 30	18	0.796	5.0	518	0.70	0.65

## General Specifications

Test Voltage.....1 V  
 Reflow Soldering ...230 °C, 50 sec. max.  
 Operating Temperature ..-40 °C to +125 °C  
 (Temperature rise included)  
 Storage Temperature..-40 °C to +125 °C  
 Resistance to Soldering Heat  
 .....260 °C for 10 sec.

## Materials

Core.....Ferrite DR and RI core  
 Wire.....Enameled copper  
 Base.....LCP E4008  
 Terminal.....Ag/Ni/Sn  
 Rated Current  
 .....Ind. drop 35 % typ. at Isat  
 Temperature Rise  
 .....40 °C max. at rated I<sub>rms</sub>  
 Packaging.....1,000 pcs. per reel

## Product Dimensions

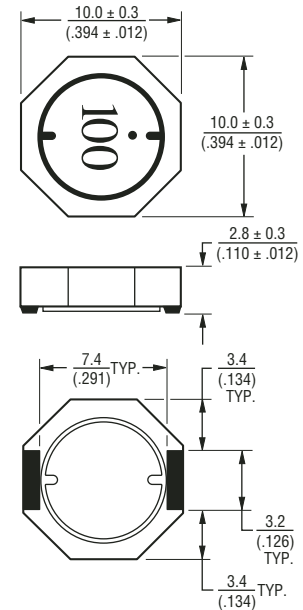

## Recommended Layout

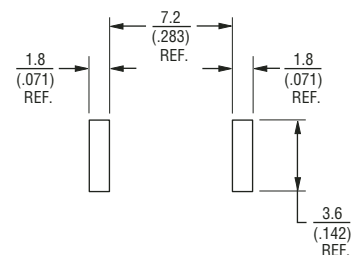

## Electrical Schematic

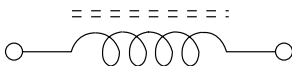

## Inductor Connection

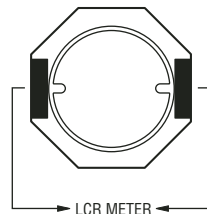

DIMENSIONS:  $\frac{\text{MM}}{\text{(INCHES)}}$

\*RoHS Directive 2002/95/EC Jan 27 2003 including Annex  
 Specifications are subject to change without notice.  
 Customers should verify actual device performance in their specific applications.

# SRU1028 Series - Shielded SMD Power Inductors

**BOURNS®**

## Packaging Specifications

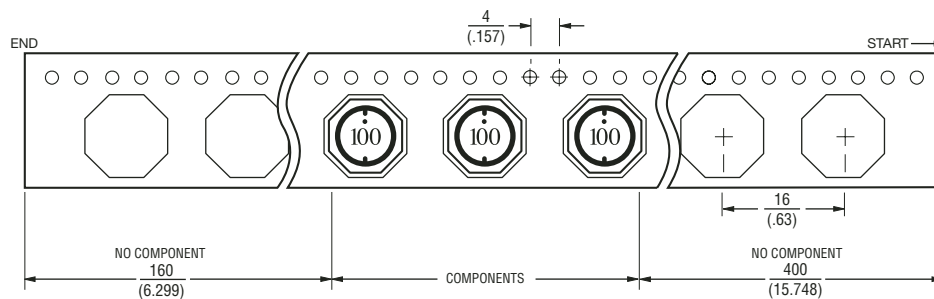
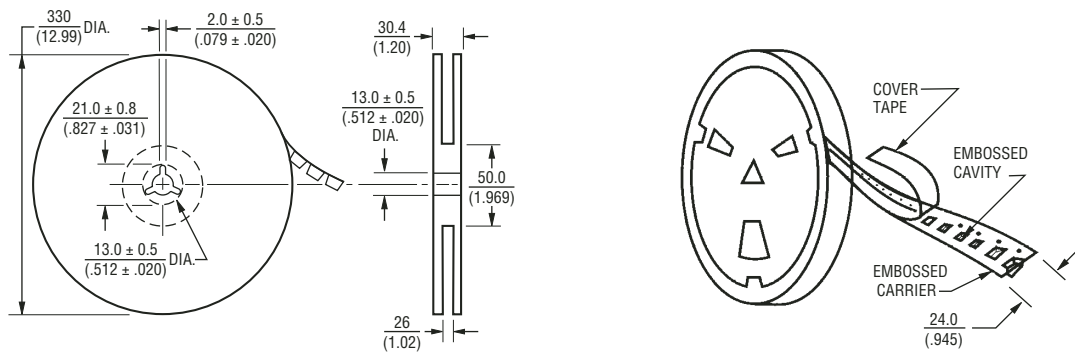

**USER DIRECTION OF FEED** →

QTY: 1,000 PCS. PER REEL

DIMENSIONS:  $\frac{\text{MM}}{\text{(INCHES)}}$

REV. 08/08

Specifications are subject to change without notice.  
Customers should verify actual device performance in their specific applications.

\*RoHS COMPLIANT

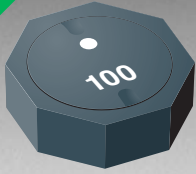

**BOURNS®**

## Features

- Available in E6 series
- Unit height of 3.8 mm
- Current up to 7.2 A
- Lead free
- RoHS compliant\*

## Applications

- Input/output of DC/DC converters
- Power supplies for:
  - Portable communication equipment
  - Camcorders
  - LCD TVs
  - Car radios

# SRU1038 Series - Shielded SMD Power Inductors

## Electrical Specifications

Bourns Part No.	Inductance 100 KHz		Q Ref.	Test Frequency (MHz)	SRF Min. (MHz)	RDC (mΩ)	I rms Max. (A)	I sat Typ. (A)
	(μH)	Tol. %						
SRU1038-1R5Y	1.5	± 30	14	7.96	65.0	5.2	7.20	7.00
SRU1038-2R2Y	2.2	± 30	12	7.96	55.0	7.7	6.80	6.50
SRU1038-2R5Y	2.5	± 30	12	7.96	50.0	12.5	6.10	6.00
SRU1038-3R5Y	3.5	± 30	14	7.96	35.0	11.5	5.50	5.50
SRU1038-3R8Y	3.8	± 30	14	7.96	35.0	15.0	5.50	5.50
SRU1038-5R0Y	5.0	± 30	12	7.96	30.0	14.5	4.60	4.80
SRU1038-5R2Y	5.2	± 30	12	7.96	30.0	22.0	4.60	4.80
SRU1038-6R2Y	6.2	± 30	12	7.96	25.0	16.5	4.00	4.20
SRU1038-7R0Y	7.0	± 30	13	7.96	36.0	35.0	3.90	4.00
SRU1038-100Y	10.0	± 30	24	7.96	20.0	25.0	3.80	3.60
SRU1038-150Y	15.0	± 30	24	2.52	16.0	37.0	2.80	2.70
SRU1038-220Y	22.0	± 30	20	2.52	12.0	55.8	2.20	2.30
SRU1038-270Y	27.0	± 30	22	2.52	11.0	78.0	1.85	1.90
SRU1038-330Y	33.0	± 30	22	2.52	10.0	86.0	1.80	1.80
SRU1038-470Y	47.0	± 30	22	2.52	8.0	121.0	1.65	1.60
SRU1038-680Y	68.0	± 30	24	2.52	7.0	166.0	1.10	1.30
SRU1038-101Y	100.0	± 30	24	0.796	6.0	220.0	1.30	1.10
SRU1038-151Y	150.0	± 30	20	0.796	5.0	358.0	0.90	0.80
SRU1038-221Y	220.0	± 30	22	0.796	4.0	565.0	0.65	0.65
SRU1038-331Y	330.0	± 30	20	0.796	3.0	773.0	0.55	0.52

## General Specifications

Test Voltage.....1 V  
 Reflow Soldering ...230 °C, 50 sec. max.  
 Operating Temperature ..-40 °C to +125 °C  
 (Temperature rise included)  
 Storage Temperature..-40 °C to +125 °C  
 Resistance to Soldering Heat  
 .....260 °C for 10 sec.

## Materials

Core.....Ferrite DR and RI core  
 Wire.....Enameled copper  
 Base.....LCP E4008  
 Terminal.....Ag/Ni/Sn  
 Rated Current  
 .....Ind. drop 35 % typ. at Isat  
 Temperature Rise  
 .....40 °C max. at rated I<sub>rms</sub>  
 Packaging.....800 pcs. per reel

## Product Dimensions

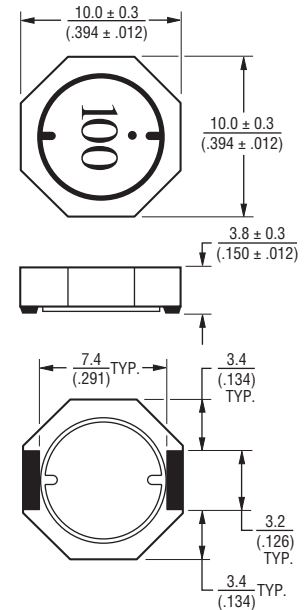

## Recommended Layout

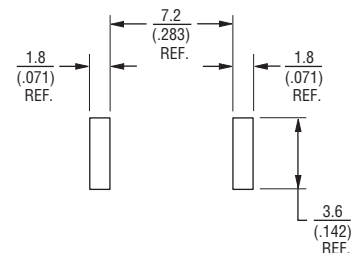

## Electrical Schematic

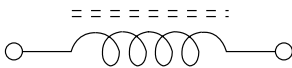

## Inductor Connection

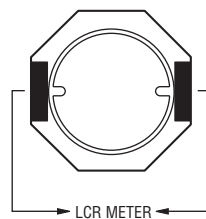

DIMENSIONS:  $\frac{\text{MM}}{\text{(INCHES)}}$

\*RoHS Directive 2002/95/EC Jan 27 2003 including Annex  
 Specifications are subject to change without notice.  
 Customers should verify actual device performance in their specific applications.



# SRU1038 Series - Shielded SMD Power Inductors

**BOURNS®**

## Packaging Specifications

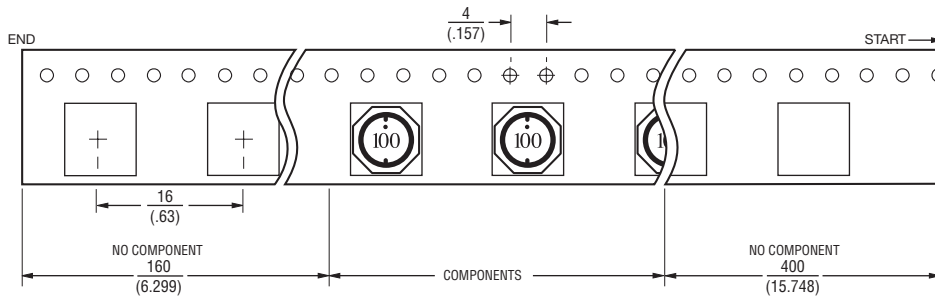
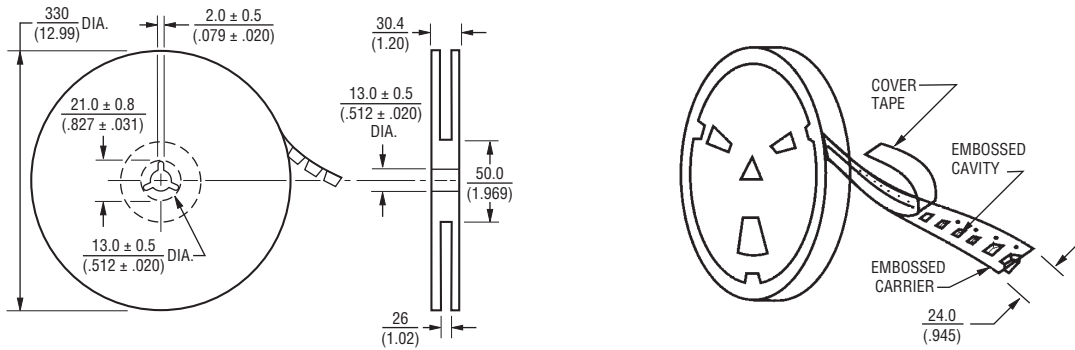

**USER DIRECTION OF FEED** →

QTY: 800 PCS. PER REEL

DIMENSIONS:  $\frac{\text{MM}}{\text{(INCHES)}}$

REV. 08/09

Specifications are subject to change without notice.

Customers should verify actual device performance in their specific applications.



### Features

- Available in E6 series
- Unit height of 4.8 mm
- Current up to 7.8 A
- Lead free
- RoHS compliant\*

### Applications

- Input/output of DC/DC converters
- Power supplies for:
  - Portable communication equipment
  - Camcorders
  - LCD TVs
  - Car radios

## SRU1048 Series - Shielded SMD Power Inductors

### Electrical Specifications

Bourns Part No.	Inductance 100 KHz		Q Ref.	Test Frequency (MHz)	SRF Min. (MHz)	RDC (mΩ)	I rms Max. (A)	I sat Typ. (A)
	(μH)	Tol. %						
SRU1048-R80Y	0.8	± 30	8	7.96	100.0	3.6	7.80	8.50
SRU1048-1R5Y	1.5	± 30	14	7.96	70.0	4.3	7.00	7.20
SRU1048-2R2Y	2.2	± 30	14	7.96	55.0	5.3	6.50	6.30
SRU1048-3R0Y	3.0	± 30	14	7.96	40.0	7.2	6.20	6.00
SRU1048-4R7Y	4.7	± 30	12	7.96	30.0	9.5	5.50	4.75
SRU1048-6R8Y	6.8	± 30	10	7.96	20.0	13.6	4.80	4.10
SRU1048-8R2Y	8.2	± 30	8	7.96	18.0	15.0	4.60	3.80
SRU1048-100Y	10.0	± 30	26	7.96	16.0	18.5	4.50	3.70
SRU1048-120Y	12.0	± 30	26	2.52	15.0	25.0	4.00	3.30
SRU1048-150Y	15.0	± 30	30	2.52	14.0	29.0	3.20	2.70
SRU1048-220Y	22.0	± 30	22	2.52	12.0	42.0	2.60	2.00
SRU1048-330Y	33.0	± 30	24	2.52	10.0	63.0	2.10	1.70
SRU1048-470Y	47.0	± 30	26	2.52	8.0	94.0	1.70	1.50
SRU1048-560Y	56.0	± 30	26	2.52	7.0	110.0	1.60	1.40
SRU1048-680Y	68.0	± 30	24	2.52	6.0	127.0	1.40	1.25
SRU1048-820Y	82.0	± 30	24	2.52	5.5	149.0	1.30	1.10
SRU1048-101Y	100.0	± 30	26	0.796	5.0	160.0	1.20	1.00
SRU1048-151Y	150.0	± 30	24	0.796	4.5	235.0	1.00	0.80
SRU1048-221Y	220.0	± 30	20	0.796	4.0	350.0	0.80	0.70
SRU1048-331Y	330.0	± 30	18	0.796	3.0	490.0	0.65	0.52

### General Specifications

Test Voltage.....1 V  
 Reflow Soldering ...230 °C, 50 sec. max.  
 Operating Temperature -40 °C to +125 °C  
 (Temperature rise included)  
 Storage Temperature..-40 °C to +125 °C  
 Resistance to Soldering Heat  
 .....260 °C for 10 sec.

### Materials

Core.....Ferrite DR and RI core  
 Wire.....Enameled copper  
 Base.....LCP E4008  
 Terminal.....Ag/Ni/Sn  
 Rated Current  
 .....Ind. drop 35 % typ. at Isat  
 Temperature Rise  
 .....30 °C max. at rated I<sub>rms</sub>  
 Packaging.....600 pcs. per reel

### Product Dimensions

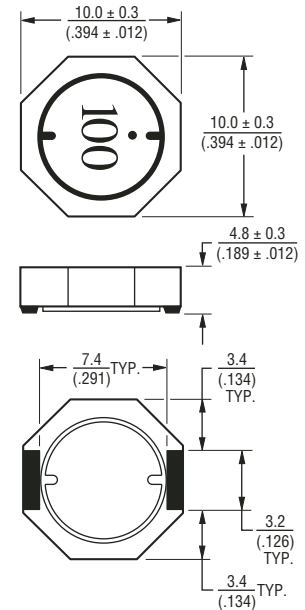

### Recommended Layout

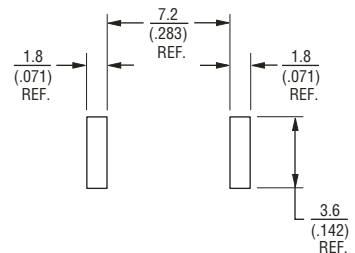

### Electrical Schematic

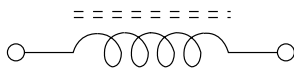

### Inductor Connection

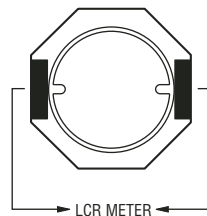

DIMENSIONS:  $\frac{\text{MM}}{\text{(INCHES)}}$

\*RoHS Directive 2002/95/EC Jan 27 2003 including Annex  
 Specifications are subject to change without notice.  
 Customers should verify actual device performance in their specific applications.

# SRU1048 Series - Shielded SMD Power Inductors

**BOURNS®**

## Packaging Specifications

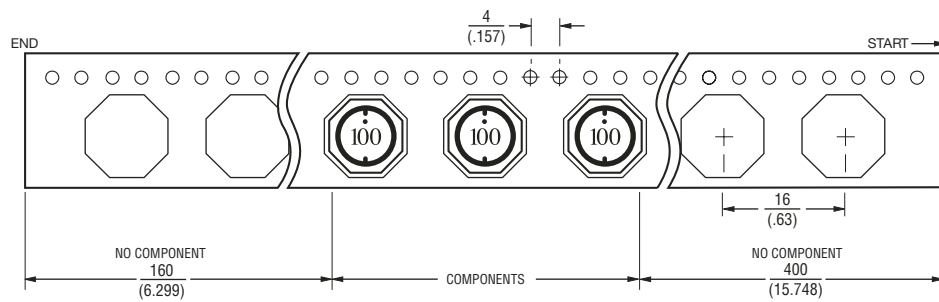
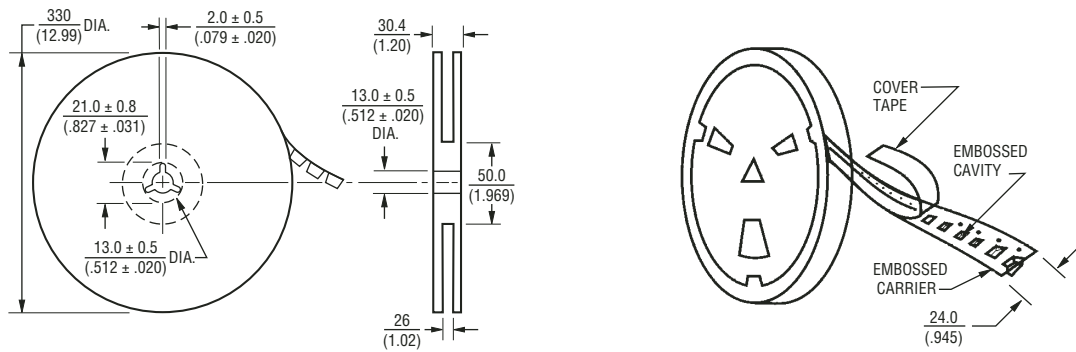

**USER DIRECTION OF FEED** →

QTY: 600 PCS. PER REEL

DIMENSIONS:  $\frac{\text{MM}}{\text{(INCHES)}}$

\*RoHS COMPLIANT

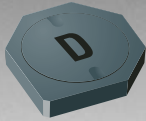

**BOURNS®**

### Features

- Available in E6 series
- Unit height of 1.1 mm
- Current up to 1.1 A
- Lead free
- RoHS compliant\*

### Applications

- Input/output of DC/DC converters
- Power supplies for:
  - Portable communication equipment
  - Camcorders
  - LCD TVs
  - Car radios

## SRU3011 Series - Shielded SMD Power Inductors

### Electrical Specifications

Bourns Part No.	Inductance 100 KHz		Q Ref.	Test Frequency (MHz)	SRF Min. (MHz)	RDC (mΩ)	I rms Max. (A)	I sat Typ. (A)	Marking
	(μH)	Tol. %							
SRU3011-1R5Y	1.5	± 30	7	7.96	180	57	1.10	1.00	A
SRU3011-2R2Y	2.2	± 30	7	7.96	150	80	0.92	0.90	B
SRU3011-3R3Y	3.3	± 30	8	7.96	120	116	0.84	0.78	C
SRU3011-4R7Y	4.7	± 30	8	7.96	90	178	0.63	0.62	D
SRU3011-6R8Y	6.8	± 30	7	7.96	85	245	0.50	0.46	E
SRU3011-100Y	10.0	± 30	8	2.52	60	340	0.40	0.35	F

### General Specifications

Test Voltage.....0.1 V  
 Reflow Soldering ...230 °C, 50 sec. max.  
 Operating Temperature ..-40 °C to +125 °C  
 (Temperature rise included)  
 Storage Temperature...-40 °C to +125 °C  
 Resistance to Soldering Heat  
 .....260 °C for 10 sec.

### Materials

Core.....Ferrite DR and RI core  
 Wire .....Enamelled copper  
 Base .....LCP E4008  
 Terminal .....Ag/Ni/Sn  
 Rated Current  
 .....Ind. drop 35 % typ. at Isat  
 Temperature Rise  
 .....40 °C max. at rated Irms  
 Packaging.....1500 pcs. per reel

### Electrical Schematic

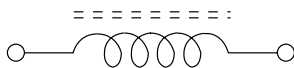

### Inductor Connection

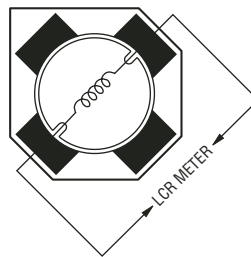

### Recommended Layout

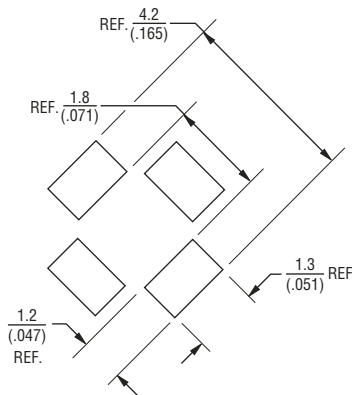

DIMENSIONS:  $\frac{\text{MM}}{\text{(INCHES)}}$

### Product Dimensions

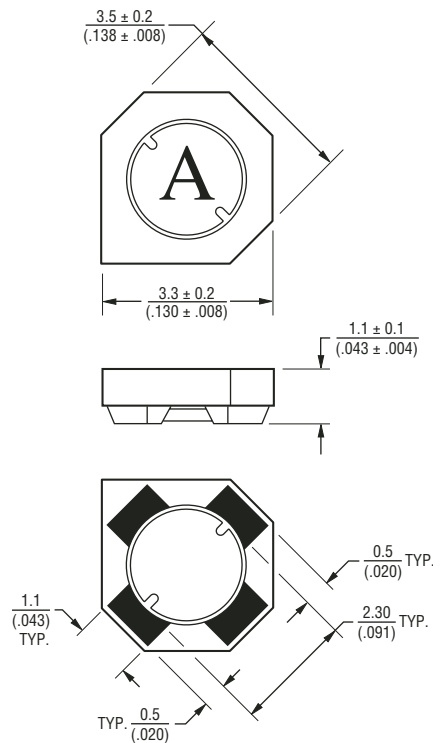

\*RoHS Directive 2002/95/EC Jan 27 2003 including Annex  
 Specifications are subject to change without notice.  
 Customers should verify actual device performance in their specific applications.

# SRU3011 Series - Shielded SMD Power Inductors

**BOURNS®**

## Packaging Specifications

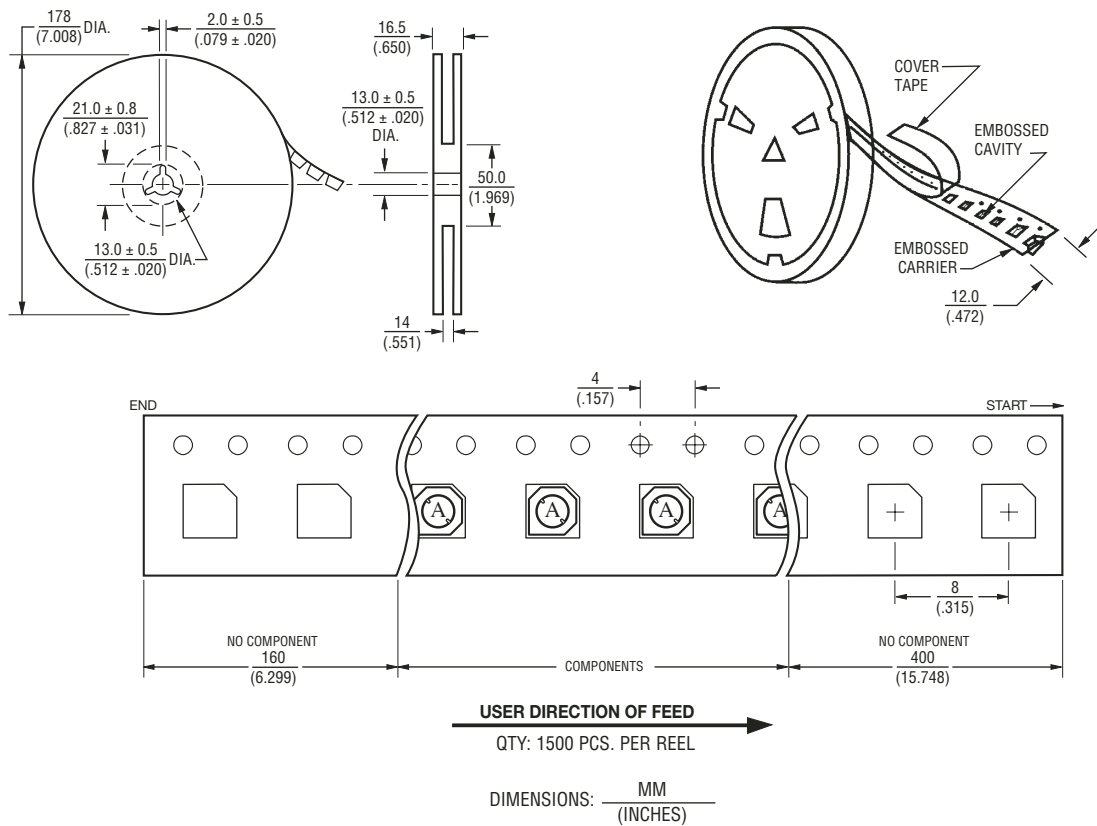

REV. 05/05

Specifications are subject to change without notice.  
Customers should verify actual device performance in their specific applications.

\*RoHS COMPLIANT

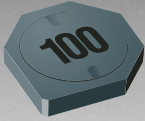

**BOURNS®**

### Features

- Available in E6 series
- Unit height of 1.8 mm
- Current up to 1.7 A
- Lead free
- RoHS compliant\*

### Applications

- Input/output of DC/DC converters
- Power supplies for:
  - Portable communication equipment
  - Camcorders
  - LCD TVs
  - Car radios

## SRU3017 Series - Shielded SMD Power Inductors

### Electrical Specifications

Bourns Part No.	Inductance 100 KHz		Q Ref.	Test Frequency (MHz)	SRF Typ. (MHz)	RDC (mΩ)	I rms Max. (A)	I sat Typ. (A)
	(μH)	Tol. %						
SRU3017-2R2Y	2.2	± 30	8	7.96	100	35	0.98	1.70
SRU3017-3R3Y	3.3	± 30	8	7.96	80	55	0.80	1.45
SRU3017-4R7Y	4.7	± 30	10	7.96	60	68	0.63	1.10
SRU3017-6R8Y	6.8	± 30	10	7.96	50	85	0.53	1.00
SRU3017-100Y	10.0	± 30	15	7.96	40	120	0.47	0.85
SRU3017-150Y	15.0	± 30	20	2.52	35	175	0.35	0.68
SRU3017-220Y	22.0	± 30	20	2.52	30	250	0.30	0.60
SRU3017-330Y	33.0	± 30	20	2.52	20	430	0.25	0.47
SRU3017-470Y	47.0	± 30	18	2.52	18	540	0.21	0.36

### General Specifications

Test Voltage.....0.1 V  
 Reflow Soldering ...230 °C, 50 sec. max.  
 Operating Temperature .-40 °C to +125 °C  
 (Temperature rise included)  
 Storage Temperature..-40 °C to +125 °C  
 Resistance to Soldering Heat  
 .....260 °C for 10 sec.

### Materials

Core.....Ferrite DR and RI core  
 Wire.....Enamelled copper (Class F)  
 Terminal .....Ag/Ni/Sn  
 Rated Current  
 .....Ind. drop 35 % typ. at Isat  
 Temperature Rise  
 .....30 °C max. at rated I rms  
 Packaging.....800 pcs. per reel

### Electrical Schematic

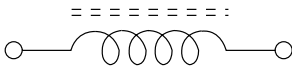

### Inductor Connection

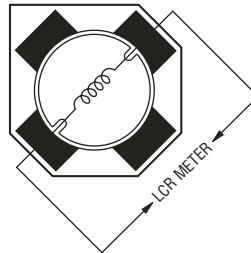

### Recommended Layout

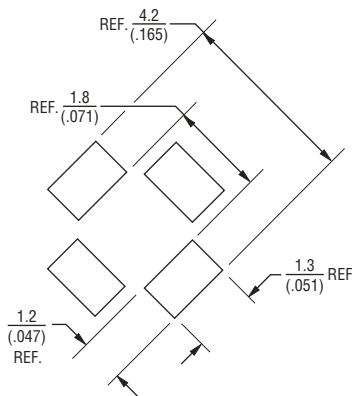

DIMENSIONS:  $\frac{\text{MM}}{\text{(INCHES)}}$

### Product Dimensions

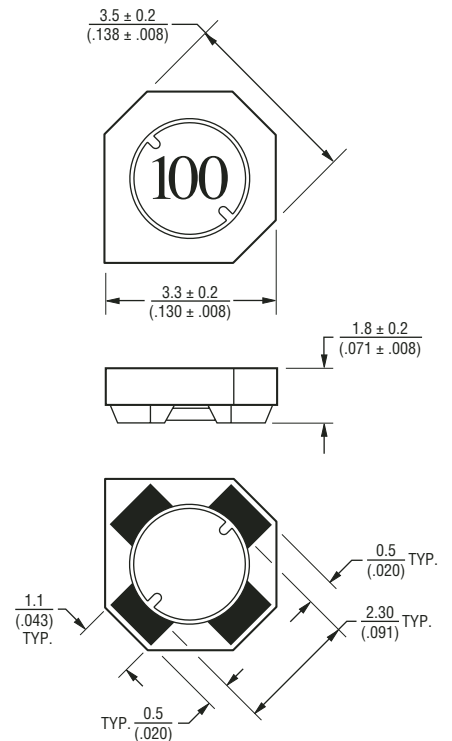

\*RoHS Directive 2002/95/EC Jan 27 2003 including Annex  
 Specifications are subject to change without notice.  
 Customers should verify actual device performance in their specific applications.

# SRU3017 Series - Shielded SMD Power Inductors

**BOURNS®**

## Packaging Specifications

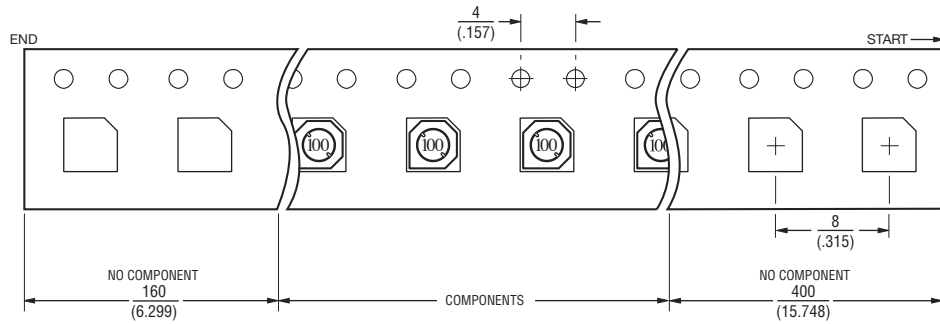
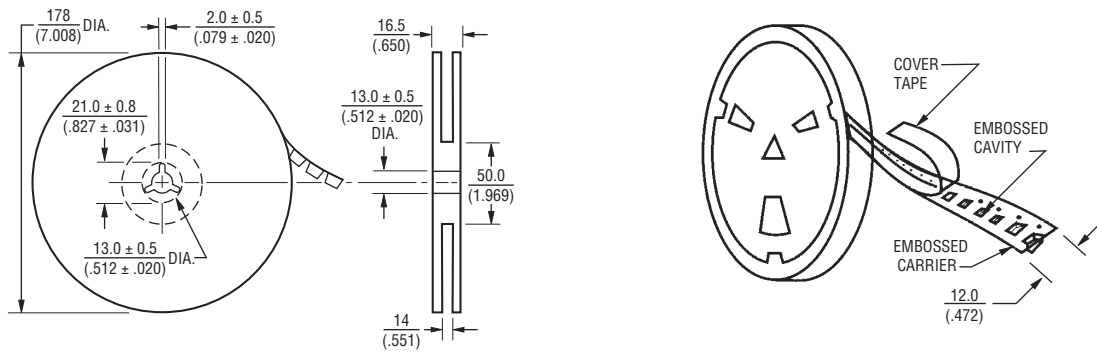

USER DIRECTION OF FEED

QTY: 800 PCS. PER REEL

DIMENSIONS:  $\frac{\text{MM}}{\text{(INCHES)}}$

REV. 09/07

Specifications are subject to change without notice.  
Customers should verify actual device performance in their specific applications.

\*RoHS COMPLIANT

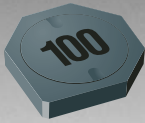

**BOURNS®**

**Features**

- Available in E6 series
- Unit height of 2.8 mm
- Current up to 0.86 A
- Lead free
- RoHS compliant\*

**Applications**

- Input/output of DC/DC converters
- Power supplies for:
  - Portable communication equipment
  - Camcorders
  - LCD TVs
  - Car radios

**SRU3028 Series - Shielded SMD Power Inductors**

**Electrical Specifications**

Bourns Part No.	Inductance 100 KHz		Q Ref.	Test Frequency (MHz)	SRF Typ. (MHz)	RDC (mΩ)	I rms Max. (A)	I sat Typ. (A)
	(μH)	Tol. %						
SRU3028-100Y	10.0	± 30	20	7.96	35	160	0.72	0.86
SRU3028-150Y	15.0	± 30	18	2.52	25	230	0.66	0.72
SRU3028-220Y	22.0	± 30	18	2.52	15	270	0.60	0.62
SRU3028-330Y	33.0	± 30	20	2.52	10	450	0.47	0.48
SRU3028-470Y	47.0	± 30	20	2.52	8	815	0.32	0.38
SRU3028-680Y	68.0	± 30	20	2.52	7	1400	0.24	0.28
SRU3028-101Y	100.0	± 30	20	0.796	5	2200	0.19	0.21

**General Specifications**

Test Voltage.....0.1 V  
 Reflow Soldering ...230 °C, 50 sec. max.  
 Operating Temperature .-40 °C to +125 °C  
 (Temperature rise included)  
 Storage Temperature...-40 °C to +125 °C  
 Resistance to Soldering Heat  
 .....260 °C for 10 sec.

**Materials**

Core.....Ferrite DR and RI core  
 Wire.....Enameled copper (Class F)  
 Terminal.....Ag/Ni/Sn  
 Rated Current  
 .....Ind. drop 35 % typ. at Isat  
 Temperature Rise  
 .....40 °C max. at rated I rms  
 Packaging.....600 pcs. per reel

**Electrical Schematic**

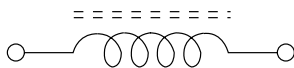

**Inductor Connection**

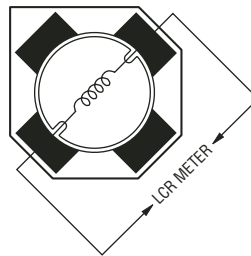

**Recommended Layout**

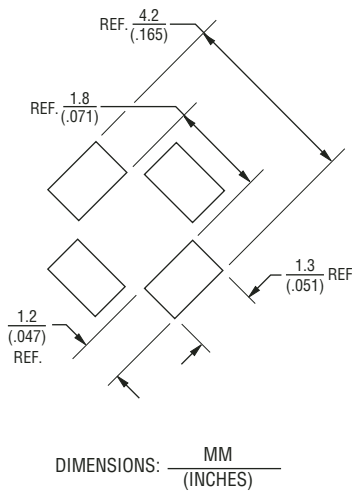

**Product Dimensions**

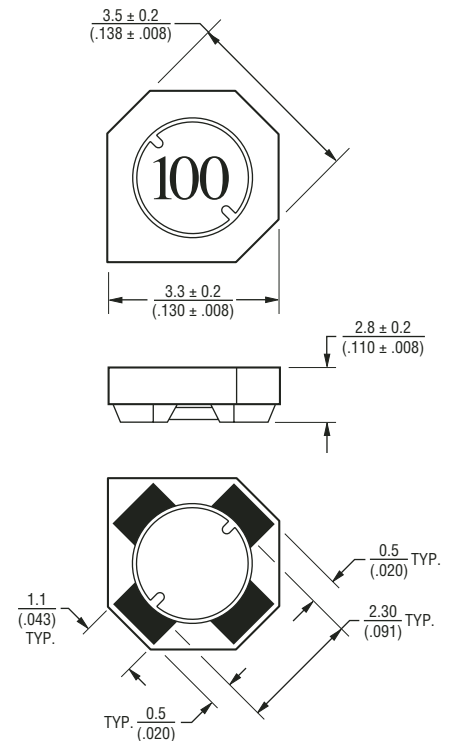

\*RoHS Directive 2002/95/EC Jan 27 2003 including Annex  
 Specifications are subject to change without notice.  
 Customers should verify actual device performance in their specific applications.



# SRU3028 Series - Shielded SMD Power Inductors

**BOURNS®**

## Packaging Specifications

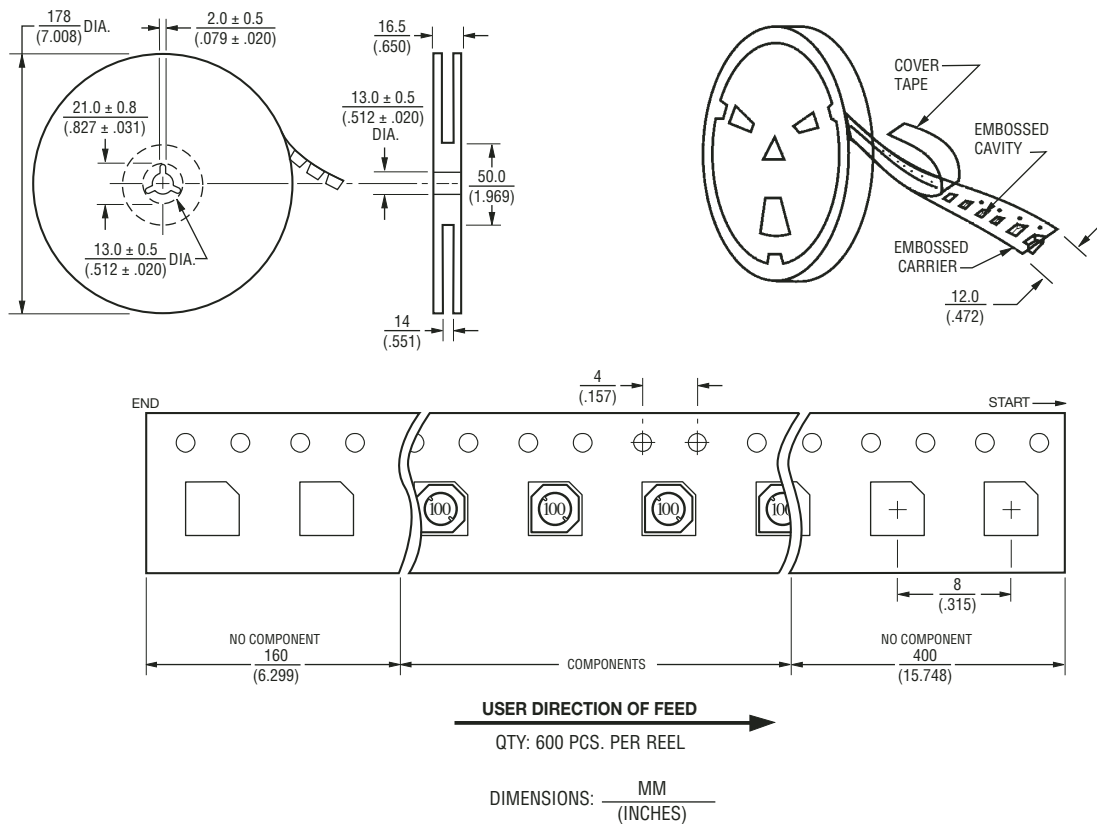

REV. 05/05

Specifications are subject to change without notice.  
Customers should verify actual device performance in their specific applications.

\*RoHS COMPLIANT

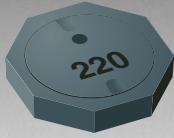

**BOURNS®**

### Features

- Available in E6 series
- Unit height of 1.1 mm
- Current up to 1800 mA
- Lead free
- RoHS compliant\*

### Applications

- Input/output of DC/DC converters
- Power supplies for:
  - Portable communication equipment
  - Camcorders
  - LCD TVs
  - Car radios

## SRU5011 Series - Shielded SMD Power Inductors

### Electrical Specifications

Bourns Part No.	Inductance 100 KHz		Q Ref.	Test Frequency (MHz)	SRF Min. (MHz)	RDC (mΩ)	I rms Max. (A)	I sat Typ. (A)
	(μH)	Tol. %						
SRU5011-1R5Y	1.5	± 30	8	7.96	195.0	32	1.80	1.50
SRU5011-2R5Y	2.5	± 30	8	7.96	125.0	52	1.30	1.10
SRU5011-3R3Y	3.3	± 30	8	7.96	110.0	66	1.15	0.94
SRU5011-4R7Y	4.7	± 30	8	7.96	85.0	95	1.00	0.82
SRU5011-6R8Y	6.8	± 30	8	7.96	70.0	130	0.82	0.68
SRU5011-100Y	10.0	± 30	12	7.96	50.0	170	0.70	0.58
SRU5011-150Y	15.0	± 30	12	2.52	42.0	250	0.60	0.48
SRU5011-220Y	22.0	± 30	14	2.52	38.0	380	0.50	0.40
SRU5011-330Y	33.0	± 30	14	2.52	30.0	550	0.38	0.30
SRU5011-470Y	47.0	± 30	16	2.52	25.0	800	0.32	0.26
SRU5011-680Y	68.0	± 30	14	2.52	20.0	1240	0.26	0.22
SRU5011-101Y	100.0	± 30	30	0.796	15.0	1600	0.20	0.18

### General Specifications

Test Voltage.....0.1 V  
 Reflow Soldering ...230 °C, 50 sec. max.  
 Operating Temperature ..-40 °C to +125 °C  
 (Temperature rise included)  
 Storage Temperature...-40 °C to +125 °C  
 Resistance to Soldering Heat  
 .....260 °C for 10 sec.

### Materials

Core.....Ferrite DR and RI core  
 Wire .....Enamelled copper  
 Base .....LCP E4008  
 Terminal .....Ag/Ni/Sn  
 Rated Current  
 .....Ind. drop 35 % typ. at Isat  
 Temperature Rise  
 .....25 °C max. at rated Irms  
 Packaging.....1500 pcs. per reel

### Electrical Schematic

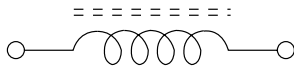

### Inductor Connection

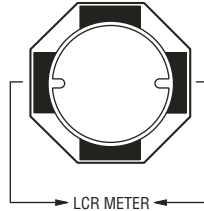

### Recommended Layout

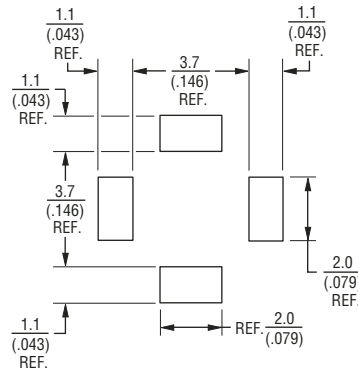

### Product Dimensions

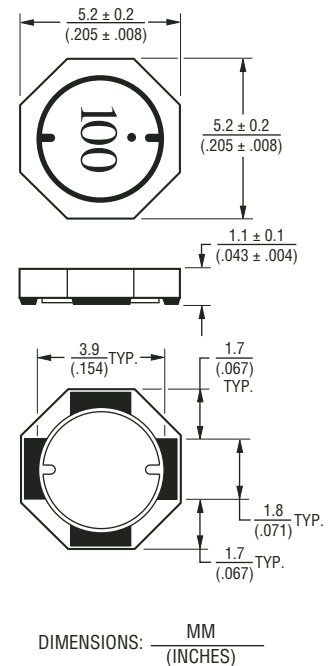

\*RoHS Directive 2002/95/EC Jan 27 2003 including Annex  
 Specifications are subject to change without notice.  
 Customers should verify actual device performance in their specific applications.

# SRU5011 Series - Shielded SMD Power Inductors

**BOURNS®**

## Packaging Specifications

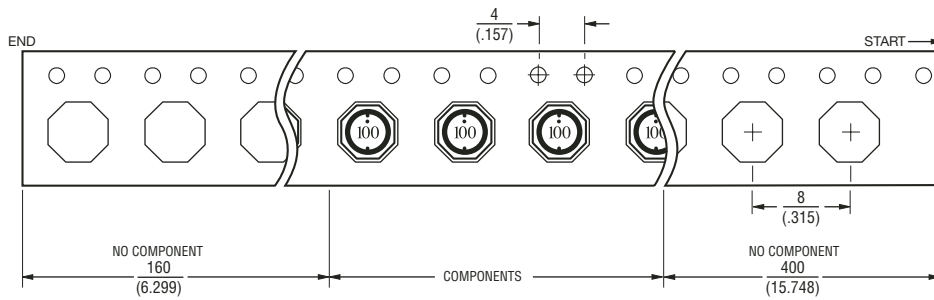
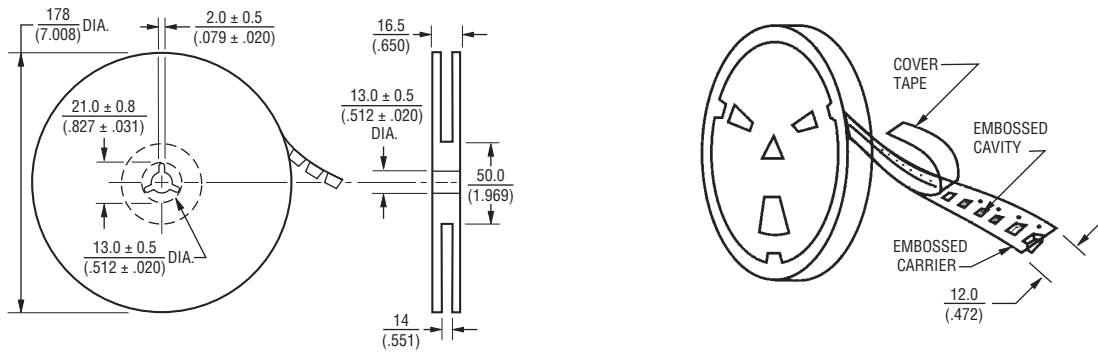

USER DIRECTION OF FEED →

QTY: 1,500 PCS. PER REEL

DIMENSIONS:  $\frac{\text{MM}}{\text{(INCHES)}}$

\*RoHS COMPLIANT

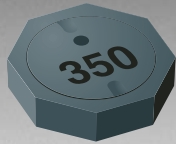

**BOURNS®**

### Features

- Available in E6 series
- Unit height of 1.6 mm
- Current up to 1.8 A
- Lead free
- RoHS compliant\*

### Applications

- Input/output of DC/DC converters
- Power supplies for:
  - Portable communication equipment
  - Camcorders
  - LCD TVs
  - Car radios

## SRU5016 Series - Shielded SMD Power Inductors

### Electrical Specifications

Bourns Part No.	Inductance 100 KHz		Q Ref.	Test Frequency (MHz)	SRF Min. (MHz)	RDC (mΩ)	I rms Max. (A)	I sat Typ. (A)
	(μH)	Tol. %						
SRU5016-1R8Y	1.8	± 30	9	7.96	100	24	1.75	1.70
SRU5016-3R3Y	3.3	± 30	9	7.96	80	35	1.55	1.50
SRU5016-4R7Y	4.7	± 30	9	7.96	60	43	1.30	1.20
SRU5016-6R8Y	6.8	± 30	8	7.96	50	50	1.20	1.10
SRU5016-100Y	10.0	± 30	15	2.52	40	84	1.00	0.90
SRU5016-150Y	15.0	± 30	15	2.52	32	130	0.80	0.72
SRU5016-220Y	22.0	± 30	15	2.52	28	195	0.65	0.56
SRU5016-330Y	33.0	± 30	13	2.52	22	300	0.54	0.50
SRU5016-470Y	47.0	± 30	18	2.52	18	390	0.46	0.42
SRU5016-680Y	68.0	± 30	18	2.52	15	560	0.36	0.33
SRU5016-101Y	100.0	± 30	18	0.796	12	850	0.30	0.27

### General Specifications

Test Voltage.....0.1 V  
 Reflow Soldering ...230 °C, 50 sec. max.  
 Operating Temperature ..-40 °C to +125 °C  
 (Temperature rise included)  
 Storage Temperature...-40 °C to +125 °C  
 Resistance to Soldering Heat  
 .....260 °C for 10 sec.

### Materials

Core.....Ferrite DR and RI core  
 Wire .....Enameled copper  
 Base .....LCP E4008  
 Terminal .....Ag/Ni/Sn  
 Rated Current  
 .....Ind. drop 35 % typ. at Isat  
 Temperature Rise  
 .....40 °C max. at rated Irms  
 Packaging.....1000 pcs. per reel

### Electrical Schematic

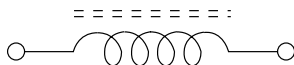

### Inductor Connection

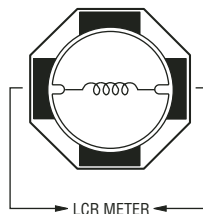

### Recommended Layout

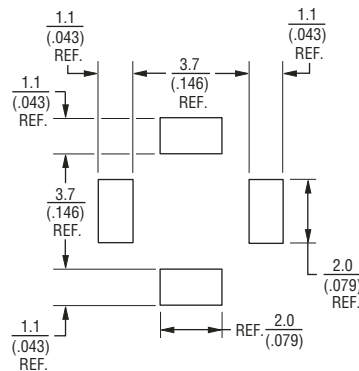

### Product Dimensions

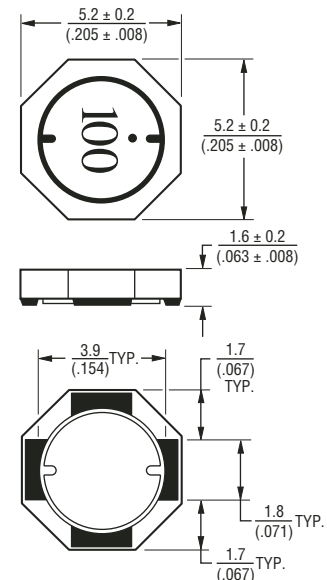

DIMENSIONS:  $\frac{\text{MM}}{\text{(INCHES)}}$

\*RoHS Directive 2002/95/EC Jan 27 2003 including Annex  
 Specifications are subject to change without notice.  
 Customers should verify actual device performance in their specific applications.

# SRU5016 Series - Shielded SMD Power Inductors

**BOURNS®**

## Packaging Specifications

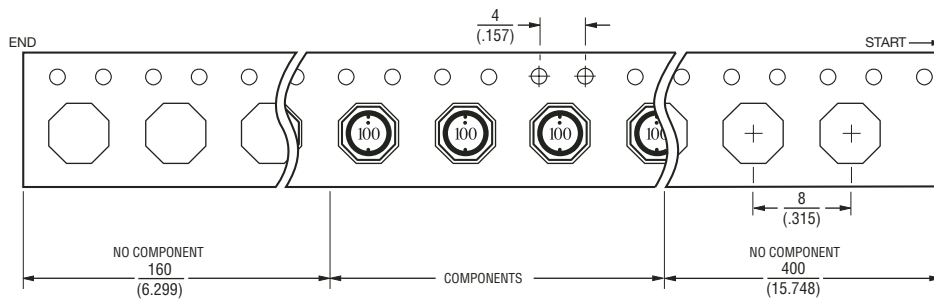
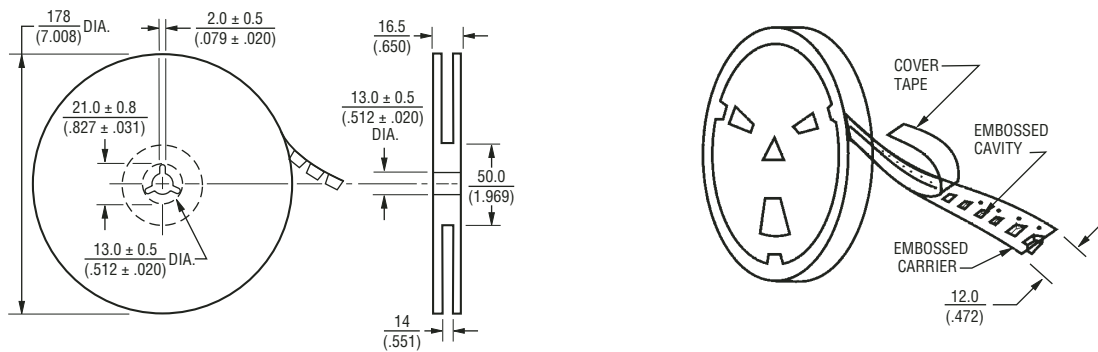

**USER DIRECTION OF FEED** →

QTY: 1,000 PCS. PER REEL

DIMENSIONS:  $\frac{\text{MM}}{\text{(INCHES)}}$

\*RoHS COMPLIANT

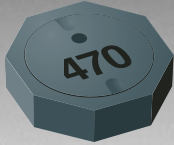

**BOURNS®**

### Features

- Available in E6 series
- Unit height of 1.8 mm
- Current up to 2.8 A
- Lead free
- RoHS compliant\*

### Applications

- Input/output of DC/DC converters
- Power supplies for:
  - Portable communication equipment
  - Camcorders
  - LCD TVs
  - Car radios

## SRU5018 Series - Shielded SMD Power Inductors

### Electrical Specifications

Bourns Part No.	Inductance 100 KHz		Q Ref.	Test Frequency (MHz)	SRF Min. (MHz)	RDC (mΩ)	I rms Max. (A)	I sat Typ. (A)
	(μH)	Tol. %						
SRU5018-1R0Y	1.0	± 30	9	7.96	200	12.5	2.80	2.85
SRU5018-1R5Y	1.5	± 30	9	7.96	160	15.5	2.50	2.40
SRU5018-2R2Y	2.2	± 30	10	7.96	130	20.5	2.30	2.10
SRU5018-3R5Y	3.5	± 30	9	7.96	90	32.0	2.10	1.70
SRU5018-4R7Y	4.7	± 30	8.5	7.96	80	36.0	2.00	1.55
SRU5018-6R8Y	6.8	± 30	7.5	7.96	60	50.0	1.45	1.20
SRU5018-100Y	10.0	± 30	12	2.52	50	65.0	1.25	1.05
SRU5018-150Y	15.0	± 30	12	2.52	40	100.0	0.95	0.80
SRU5018-220Y	22.0	± 30	12	2.52	28	160.0	0.68	0.65
SRU5018-330Y	33.0	± 30	13	2.52	23	220.0	0.66	0.56
SRU5018-470Y	47.0	± 30	13	2.52	18	330.0	0.54	0.45
SRU5018-680Y	68.0	± 30	12	2.52	16	480.0	0.37	0.36
SRU5018-101Y	100.0	± 30	15	0.796	15	620.0	0.32	0.31

### General Specifications

Test Voltage.....0.1 V  
 Reflow Soldering ...230 °C, 50 sec. max.  
 Operating Temperature ..-40 °C to +125 °C  
 (Temperature rise included)  
 Storage Temperature...-40 °C to +125 °C  
 Resistance to Soldering Heat  
 .....260 °C for 10 sec.

### Materials

Core.....Ferrite DR and RI core  
 Wire .....Enamelled copper  
 Base .....LCP E4008  
 Terminal .....Ag/Ni/Sn  
 Rated Current  
 .....Ind. drop 35 % typ. at Isat  
 Temperature Rise  
 .....30 °C max. at rated Irms  
 Packaging.....1000 pcs. per reel

### Electrical Schematic

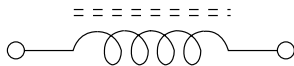

### Inductor Connection

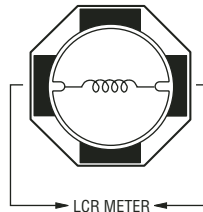

### Product Dimensions

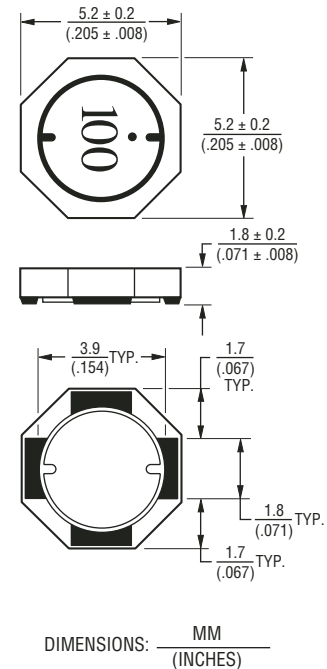

### Recommended Layout

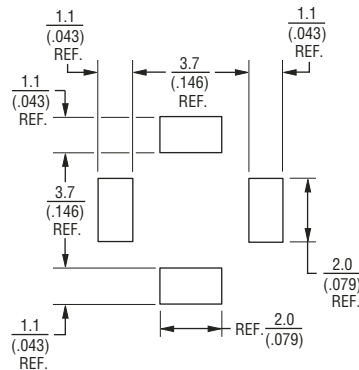

\*RoHS Directive 2002/95/EC Jan 27 2003 including Annex  
 Specifications are subject to change without notice.  
 Customers should verify actual device performance in their specific applications.

# SRU5018 Series - Shielded SMD Power Inductors

**BOURNS®**

## Packaging Specifications

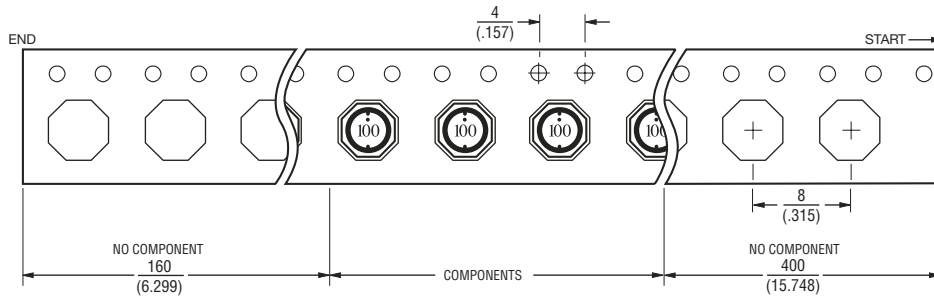
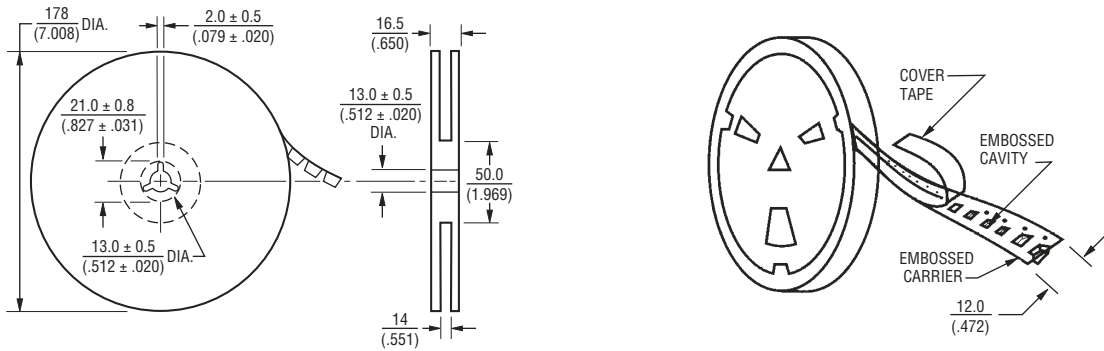

**USER DIRECTION OF FEED**  
 QTY: 1,000 PCS. PER REEL

DIMENSIONS:  $\frac{\text{MM}}{\text{(INCHES)}}$

\*RoHS COMPLIANT

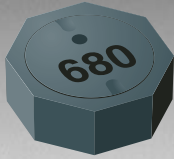

**BOURNS®**

### Features

- Available in E6 series
- Unit height of 2.8 mm
- Current up to 3.5 A
- Lead free
- RoHS compliant\*

### Applications

- Input/output of DC/DC converters
- Power supplies for:
  - Portable communication equipment
  - Camcorders
  - LCD TVs
  - Car radios

## SRU5028 Series - Shielded SMD Power Inductors

### Electrical Specifications

Bourns Part No.	Inductance 100 KHz		Q Ref.	Test Frequency (MHz)	SRF Min. (MHz)	RDC (mΩ)	I rms Max. (A)	I sat Typ. (A)
	(μH)	Tol. %						
SRU5028-1R2Y	1.2	± 30	10	7.96	200	16.8	3.50	3.40
SRU5028-2R2Y	2.2	± 30	10	7.96	130	21.0	3.20	2.50
SRU5028-3R3Y	3.3	± 30	10	7.96	90	24.0	2.80	2.10
SRU5028-4R7Y	4.7	± 30	9	7.96	50	32.0	2.20	1.85
SRU5028-6R8Y	6.8	± 30	10	7.96	55	42.0	2.00	1.55
SRU5028-100Y	10.0	± 30	18	2.52	25	63.0	1.80	1.40
SRU5028-150Y	15.0	± 30	18	2.52	23	108.0	1.10	1.00
SRU5028-220Y	22.0	± 30	15	2.52	18	162.0	0.95	0.85
SRU5028-330Y	33.0	± 30	15	2.52	16	203.0	0.80	0.68
SRU5028-470Y	47.0	± 30	13	2.52	13	285.0	0.70	0.62
SRU5028-680Y	68.0	± 30	13	2.52	10	450.0	0.56	0.46
SRU5028-101Y	100.0	± 30	15	0.796	8	625.0	0.47	0.42

### General Specifications

Test Voltage.....0.1 V  
 Reflow Soldering ...230 °C, 50 sec. max.  
 Operating Temperature .-40 °C to +125 °C  
 (Temperature rise included)  
 Storage Temperature...-40 °C to +125 °C  
 Resistance to Soldering Heat  
 .....260 °C for 10 sec.

### Materials

Core.....Ferrite DR and RI core  
 Wire .....Enamelled copper  
 Base .....LCP E4008  
 Terminal .....Ag/Ni/Sn  
 Rated Current  
 .....Ind. drop 35 % typ. at Isat  
 Temperature Rise  
 .....40 °C max. at rated Irms  
 Packaging.....600 pcs. per reel

### Electrical Schematic

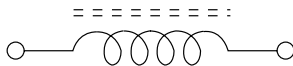

### Inductor Connection

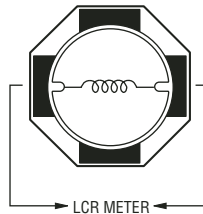

### Recommended Layout

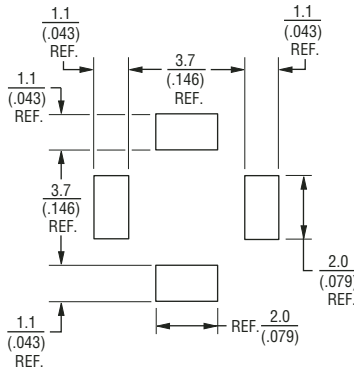

### Product Dimensions

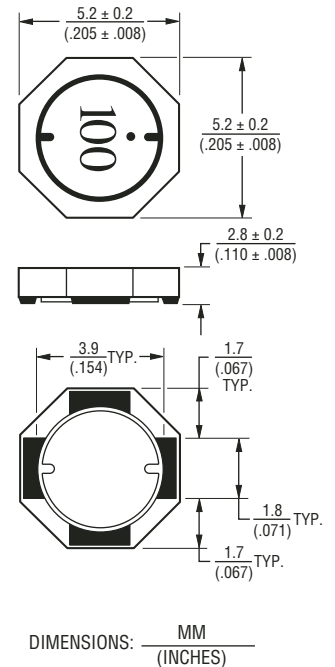

\*RoHS Directive 2002/95/EC Jan 27 2003 including Annex  
 Specifications are subject to change without notice.  
 Customers should verify actual device performance in their specific applications.



# SRU5028 Series - Shielded SMD Power Inductors

**BOURNS®**

## Packaging Specifications

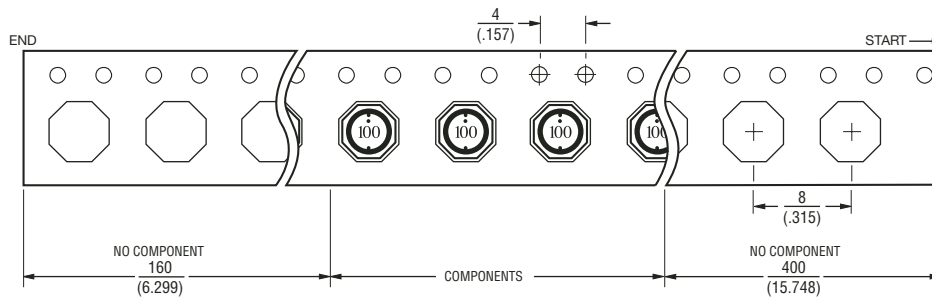
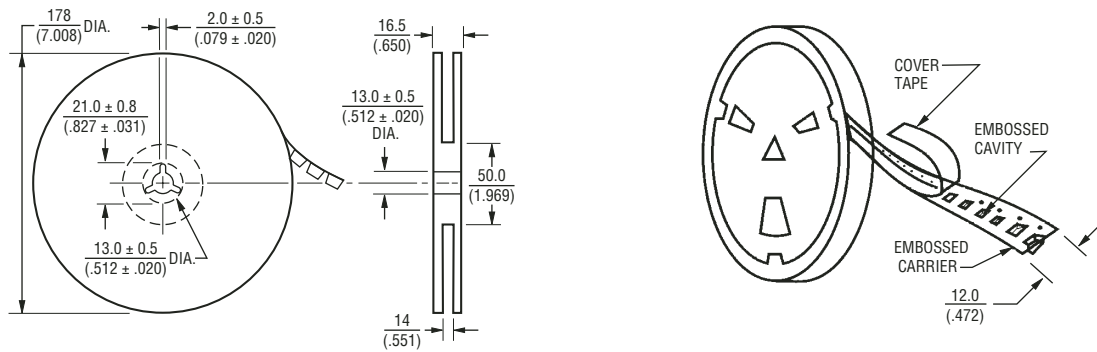

**USER DIRECTION OF FEED** →

QTY: 600 PCS. PER REEL

DIMENSIONS:  $\frac{\text{MM}}{\text{(INCHES)}}$

REV. 05/05

Specifications are subject to change without notice.  
Customers should verify actual device performance in their specific applications.

\*RoHS COMPLIANT

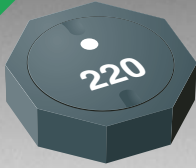

**BOURNS®**

**Features**

- Available in E6 series
- Unit height of 2.8 mm
- Current up to 4.5 A
- Lead free
- RoHS compliant\*

**Applications**

- Input/output of DC/DC converters
- Power supplies for:
  - Portable communication equipment
  - Camcorders
  - LCD TVs
  - Car radios

**SRU8028 Series - Shielded SMD Power Inductors**

**Electrical Specifications**

Bourns Part No.	Inductance 100 KHz		Q Ref.	Test Frequency (MHz)	SRF Min. (MHz)	RDC (mΩ)	I rms Max. (A)	I sat Typ. (A)
	(μH)	Tol. %						
SRU8028-2R5Y	2.5	± 30	15	7.96	65.0	13.6	4.50	4.20
SRU8028-3R3Y	3.3	± 30	12	7.96	60.0	17.5	3.60	3.50
SRU8028-4R7Y	4.7	± 30	15	7.96	50.0	20.0	3.70	3.20
SRU8028-8R2Y	8.2	± 30	17	7.96	37.0	54.0	2.60	2.30
SRU8028-6R8Y	6.8	± 30	13	7.96	40.0	34.0	2.80	2.50
SRU8028-100Y	10.0	± 30	22	2.52	35.0	45.0	2.60	2.20
SRU8028-120Y	12.0	± 30	21	2.52	30.0	76.0	2.20	2.00
SRU8028-150Y	15.0	± 30	20	2.52	25.0	66.0	2.00	1.70
SRU8028-220Y	22.0	± 30	22	2.52	20.0	106	1.60	1.50
SRU8028-330Y	33.0	± 30	20	2.52	15.0	147	1.30	1.10
SRU8028-470Y	47.0	± 30	14	2.52	12.0	177	1.20	1.00
SRU8028-680Y	68.0	± 30	23	2.52	9.0	317	0.85	0.80
SRU8028-101Y	100.0	± 30	35	0.796	8.0	390	0.75	0.70

**General Specifications**

Test Voltage.....1 V  
 Reflow Soldering ...230 °C, 50 sec. max.  
 Operating Temperature -40 °C to +125 °C  
 (Temperature rise included)  
 Storage Temperature..-40 °C to +125 °C  
 Resistance to Soldering Heat  
 .....260 °C for 10 sec.

**Materials**

Core.....Ferrite DR and RI core  
 Wire.....Enamelled copper  
 Base.....LCP E4008  
 Terminal.....Ag/Ni/Sn  
 Rated Current  
 .....Ind. drop 35 % typ. at Isat  
 Temperature Rise  
 .....40 °C max. at rated I<sub>rms</sub>  
 Packaging.....1500 pcs. per reel

**Product Dimensions**

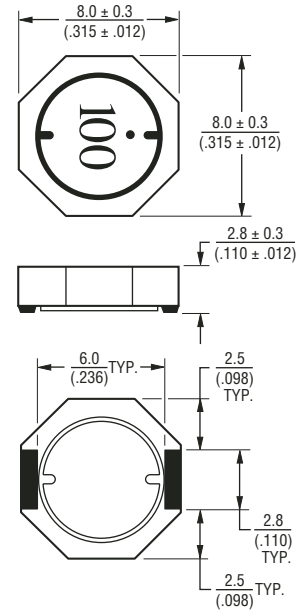

**Recommended Layout**

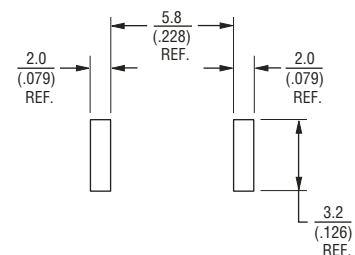

**Electrical Schematic**

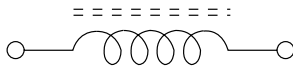

**Inductor Connection**

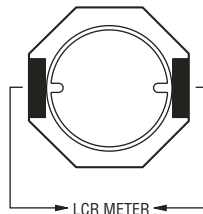

DIMENSIONS:  $\frac{\text{MM}}{\text{(INCHES)}}$

\*RoHS Directive 2002/95/EC Jan 27 2003 including Annex  
 Specifications are subject to change without notice.  
 Customers should verify actual device performance in their specific applications.

# SRU8028 Series - Shielded SMD Power Inductors

**BOURNS®**

## Packaging Specifications

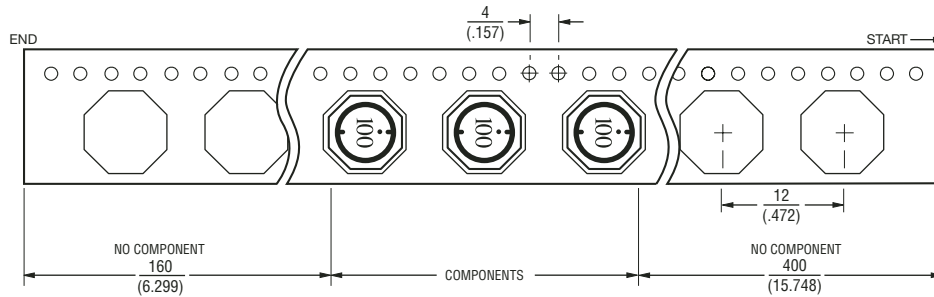
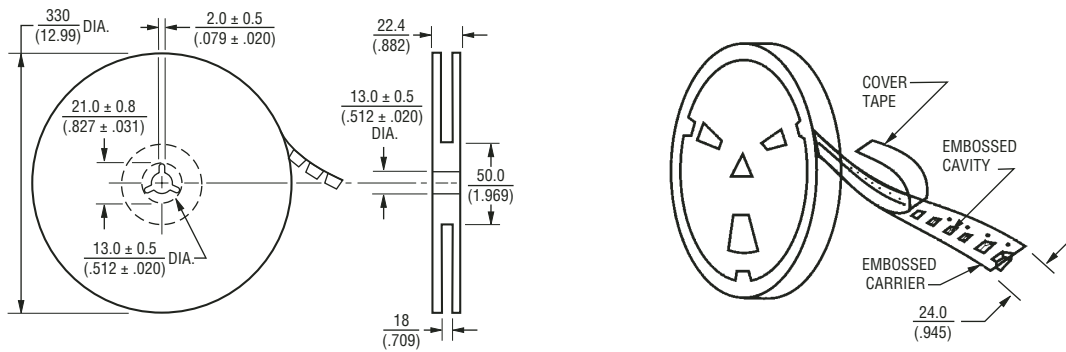

USER DIRECTION OF FEED

QTY: 1,500 PCS. PER REEL

DIMENSIONS:  $\frac{\text{MM}}{\text{(INCHES)}}$

REV. 08/08

Specifications are subject to change without notice.  
Customers should verify actual device performance in their specific applications.



### Features

- Available in E6 series
- Unit height of 4.3 mm
- Current up to 5.4 A
- Lead free
- RoHS compliant\*

### Applications

- Input/output of DC/DC converters
- Power supplies for:
  - Portable communication equipment
  - Camcorders
  - LCD TVs
  - Car radios

## SRU8043 Series - Shielded SMD Power Inductors

### Electrical Specifications

Bourns Part No.	Inductance 100 KHz		Q Ref.	Test Frequency (MHz)	SRF Min. (MHz)	RDC (mΩ)	I rms Max. (A)	I sat Typ. (A)
	(μH)	Tol. %						
SRU8043-2R2Y	2.2	± 30	15	7.96	65.0	11.2	5.40	5.20
SRU8043-3R9Y	3.9	± 30	15	7.96	42.0	14.6	4.80	4.00
SRU8043-4R7Y	4.7	± 30	13	7.96	36.0	17.0	4.60	3.60
SRU8043-6R8Y	6.8	± 30	12	7.96	30.0	22.4	3.80	3.10
SRU8043-100Y	10	± 30	27	2.52	20.0	30.0	3.50	2.70
SRU8043-120Y	12	± 30	15	2.52	15.0	39.0	2.80	2.20
SRU8043-150Y	15	± 30	26	2.52	15.0	46.0	2.70	2.00
SRU8043-180Y	18	± 30	15	2.52	15.0	62.0	2.30	1.70
SRU8043-220Y	22	± 30	24	2.52	12.0	72.5	2.20	1.70
SRU8043-270Y	27	± 30	17	2.52	12.0	84.0	1.80	1.55
SRU8043-330Y	33	± 30	21	2.52	11.0	100.0	1.70	1.40
SRU8043-470Y	47	± 30	21	2.52	9.0	120.0	1.50	1.20
SRU8043-680Y	68	± 30	20	2.52	7.0	192.0	1.20	1.00
SRU8043-101Y	100	± 30	50	0.796	6.0	287.0	1.00	0.80

### General Specifications

Test Voltage.....1 V  
 Reflow Soldering ...230 °C, 50 sec. max.  
 Operating Temperature -40 °C to +125 °C  
 (Temperature rise included)  
 Storage Temperature..-40 °C to +125 °C  
 Resistance to Soldering Heat  
 .....260 °C for 10 sec.

### Materials

Core.....Ferrite DR and RI core  
 Wire.....Enamelled copper  
 Base.....LCP E4008  
 Terminal.....Ag/Ni/Sn  
 Rated Current  
 .....Ind. drop 35 % typ. at Isat  
 Temperature Rise  
 .....40 °C max. at rated I<sub>rms</sub>  
 Packaging.....1000 pcs. per reel

### Product Dimensions

### Electrical Schematic

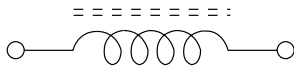

### Inductor Connection

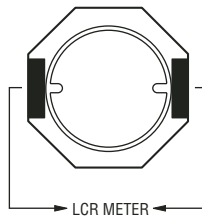

DIMENSIONS:  $\frac{\text{MM}}{\text{(INCHES)}}$

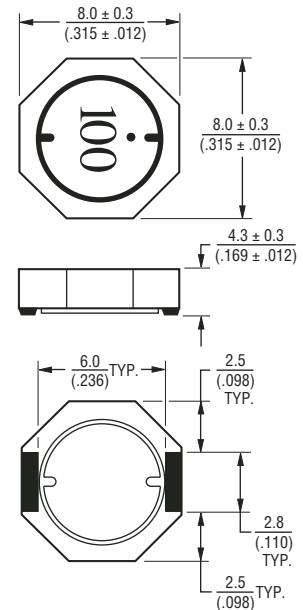

### Recommended Layout

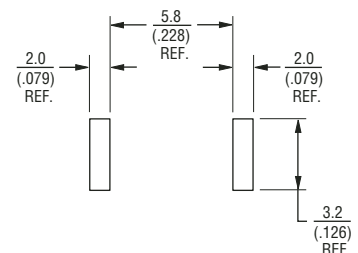

\*RoHS Directive 2002/95/EC Jan 27 2003 including Annex  
 Specifications are subject to change without notice.  
 Customers should verify actual device performance in their specific applications.

# SRU8043 Series - Shielded SMD Power Inductors

**BOURNS®**

## Packaging Specifications

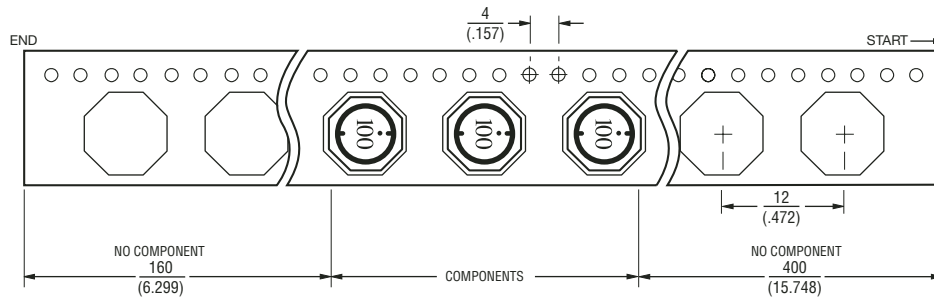
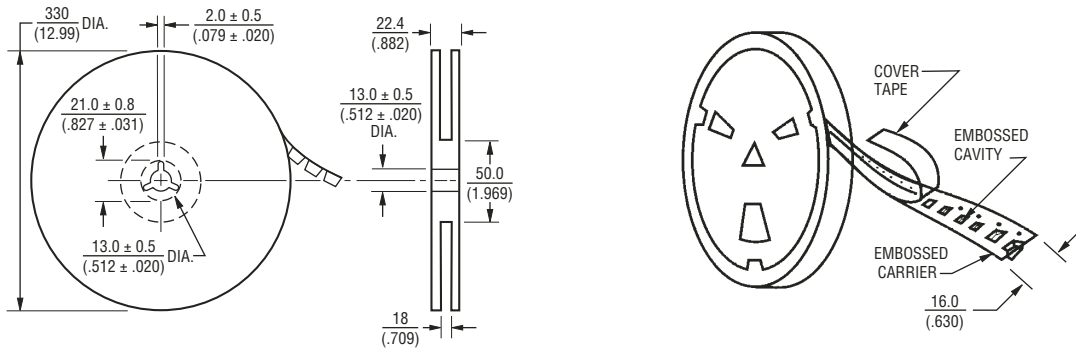

**USER DIRECTION OF FEED** →

QTY: 1,000 PCS. PER REEL

DIMENSIONS:  $\frac{\text{MM}}{\text{(INCHES)}}$

REV. 02/08

Specifications are subject to change without notice.  
Customers should verify actual device performance in their specific applications.



---

### **III. Surface Mount Chip Beads**

Product Capability Matrix.....	152
Impedance Range .....	152
Current Range .....	153

#### Product Specifications

- *MH Series High Current Chip Beads*.....154
- *MG, MU, MZ Series High Impedance Chip Beads*.....163
- *MT Series Low Current/Low Impedance Chip Beads* .....172
- *MA Series Chip Ferrite Bead Arrays* .....177

# Multi-Layer Chip Beads Product Capability Matrix



## Product Selection Guide

Model	Impedance		Current		Sealed	Size - mm (L x W x H)
	High	Low	High	Low		
MA3216	●			●	●	3.2 x 1.6 x 0.8
MH4532		●	●		●	4.5 x 3.2 x 1.5
MH4516		●	●		●	4.5 x 1.6 x 1.6
MH3225		●	●		●	3.2 x 2.5 x 1.3
MH3261		●	●		●	3.2 x 1.6 x 1.1
MH2029		●	●		●	2.0 x 1.2 x 0.9
MH1608		●	●		●	1.6 x 0.8 x 0.8
MG3261, MU3261, MZ3261	●			●	●	3.2 x 1.6 x 1.1
MG2029, MU2029, MZ2029	●			●	●	2.0 x 1.2 x 0.9
MG1608, MU1608, MZ1608	●			●	●	1.6 x 0.8 x 0.8
MU1005	●			●	●	1.0 x 0.5 x 0.5
MT4532		●		●	●	4.5 x 3.2 x 1.5
MT4516		●		●	●	4.5 x 1.6 x 1.6
MT3225		●		●	●	2.0 x 1.25 x 1.25
MT3266		●		●	●	3.2 x 1.6 x 1.6
MT3261		●		●	●	3.2 x 1.6 x 1.1
MT2029		●		●	●	2.0 x 1.2 x 0.9
MT1608		●		●	●	1.6 x 0.8 x 0.8

## Impedance

Model	Impedance (ohms) at 100MHz																					
	1.0			10				50				100				200				500	1000	2000
MA3216																						
MH4532																						
MH4516																						
MH3225																						
MH3261																						
MH2029																						
MH1608																						
MG3261, MU3261, MZ3261																						
MG2029, MU2029, MZ2029																						
MG1608, MU1608, MZ1608																						
MU1005																						
MT4532																						
MT4516																						
MT3225																						
MT3266																						
MT3261																						
MT2029																						
MT1608																						

Specifications are subject to change without notice. Customers should verify actual device performance in their specific applications.



# Multi-Layer Chip Beads Product Capability Matrix



## Current

Model	Current IDC (A) max.												
	0.0	0.1	0.5	1.0	2.0	3.0	4.0	6.0					
MA3216													
MH4532													
MH4516													
MH3225													
MH3261													
MH2029													
MH1608													
MG3261, MU3261, MZ3261													
MG2029, MU2029, MZ2029													
MG1608, MU1608, MZ1608													
MU1005													
MT4532													
MT4516													
MT3225													
MT3266													
MT3261													
MT2029													
MT1608													

Specifications are subject to change without notice.  
 Customers should verify actual device performance in their specific applications.

\*RoHS COMPLIANT

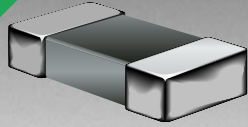

**BOURNS®**

## Features

- High resistance to heat and humidity
- Resistance to mechanical shock and pressure
- Accurate dimensions for automatic surface mounting
- Wide impedance range

## Applications

- Power supply lines
- IC power lines
- Signal lines

# MH Series High Current Chip Ferrite Beads

### Electrical Specifications

Model Number	Impedance ( $\Omega$ ) at 100 MHz	RDC ( $m\Omega$ ) Max.	IDC (A) Max.
MH4532-700Y	70 $\pm$ 25 %	30	6.0
MH4532-800Y	80 $\pm$ 25 %	10	6.0
MH4532-121Y	120 $\pm$ 25 %	50	3.0
MH4532-131Y	130 $\pm$ 25 %	40	3.0
MH4532-151Y	150 $\pm$ 25 %	20	5.0
MH4532-681Y	680 $\pm$ 25 %	30	4.0
MH4532-132Y	1300 $\pm$ 25 %	60	3.0
MH4516-600Y	60 $\pm$ 25 %	10	6.0
MH4516-750Y	75 $\pm$ 25 %	25	3.0
MH4516-800Y	80 $\pm$ 25 %	50	3.0
MH4516-102Y	1000 $\pm$ 25 %	150	1.5
MH3261-190Y	19 $\pm$ 25 %	40	3.0
MH3261-260Y	26 $\pm$ 25 %	40	3.0
MH3261-310Y	31 $\pm$ 25 %	40	3.0
MH3261-500Y	50 $\pm$ 25 %	25	3.0
MH3261-700Y	70 $\pm$ 25 %	30	4.0
MH3261-800Y	80 $\pm$ 25 %	30	4.0
MH3261-900Y	90 $\pm$ 25 %	40	3.0
MH3261-101Y	100 $\pm$ 25 %	30	4.0
MH3261-121Y	120 $\pm$ 25 %	100	2.0
MH3261-151Y	150 $\pm$ 25 %	100	2.0
MH3261-301Y	300 $\pm$ 25 %	200	1.0
MH3261-471Y	470 $\pm$ 25 %	200	1.0
MH3261-501Y	500 $\pm$ 25 %	40	3.0
MH3261-601Y	600 $\pm$ 25 %	100	2.0
MH3225-300Y	30 $\pm$ 25 %	50	3.0
MH3225-520Y	52 $\pm$ 25 %	50	3.0
MH3225-650Y	65 $\pm$ 25 %	30	3.0
MH3225-900Y	90 $\pm$ 25 %	100	2.0
MH3225-151Y	150 $\pm$ 25 %	20	5.0
MH3225-201Y	200 $\pm$ 25 %	30	4.0
MH2029-070Y	7 $\pm$ 25 %	30	3.0
MH2029-100Y	10 $\pm$ 25 %	10	6.0
MH2029-300Y	30 $\pm$ 25 %	25	3.0
MH2029-400Y	40 $\pm$ 25 %	20	5.0
MH2029-600Y	60 $\pm$ 25 %	20	5.0
MH2029-800Y	80 $\pm$ 25 %	40	3.0
MH2029-101Y	100 $\pm$ 25 %	100	2.0
MH2029-121Y	120 $\pm$ 25 %	100	2.0
MH2029-151Y	150 $\pm$ 25 %	100	2.0
MH2029-221Y	220 $\pm$ 25 %	100	2.0
MH2029-301Y	300 $\pm$ 25 %	200	1.0
MH2029-401Y	400 $\pm$ 25 %	100	2.0
MH2029-471Y	470 $\pm$ 25 %	200	1.0
MH2029-601Y	600 $\pm$ 25 %	200	1.0
MH1608-100Y	10 $\pm$ 25 %	100	6.0
MH1608-300Y	30 $\pm$ 25 %	60	3.0
MH1608-600Y	60 $\pm$ 25 %	40	3.0
MH1608-800Y	80 $\pm$ 25 %	40	3.0
MH1608-101Y	100 $\pm$ 25 %	40	3.0
MH1608-121Y	120 $\pm$ 25 %	100	2.0
MH1608-151Y	150 $\pm$ 25 %	100	2.0
MH1608-221Y	220 $\pm$ 25 %	100	2.0
MH1608-301Y	300 $\pm$ 25 %	200	1.0
MH1608-471Y	470 $\pm$ 25 %	200	1.0
MH1608-601Y	600 $\pm$ 25 %	200	1.0

### General Specifications

Operating Temperature  
 .....-55 °C to +125 °C  
 Storage Temperature...-55 °C to +125 °C  
 Storage Condition  
 .....+40 °C max. at 70 % RH  
 Reflow Soldering  
 .....230 °C, 50 seconds max.  
 Resistance to Soldering Heat  
 .....260 °C, 5 seconds  
 Rated Current .....Based on max.  
 temperature rise of +40 °C  
 Terminal Strength  
 (Force "F" applied for 30 seconds)  
 4532 Series .....1.5 F (Kg)  
 4516 Series .....1.0 F (Kg)  
 3261 Series .....1.0 F (Kg)  
 3225 Series .....1.0 F (Kg)  
 2029 Series .....0.6 F (Kg)  
 1608 Series .....0.5 F (Kg)

### Materials

Core Material .....Ferrite  
 Internal Conductor .....Ag or Ag/Pd  
 Terminal .....Ag/Ni/Sn

\*RoHS Directive 2002/95/EC Jan 27 2003 including Annex  
 Specifications are subject to change without notice.  
 Customers should verify actual device performance in their specific applications.

# MH Series High Current Chip Ferrite Beads

**BOURNS®**

## Electrical Specifications (continued)

**MH 4532- 700Y**

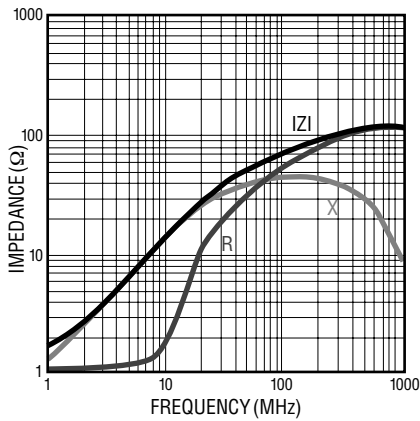

**MH 4532- 800Y**

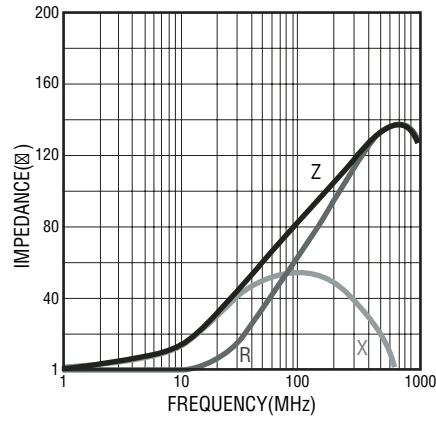

**MH 4532- 121Y**

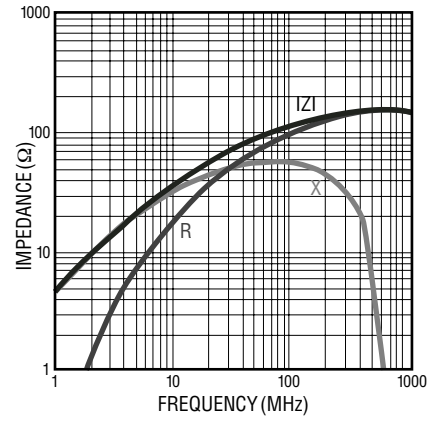

**MH 4532- 131Y**

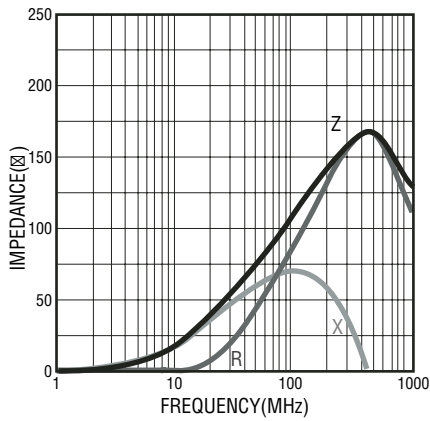

**MH 4532- 151Y**

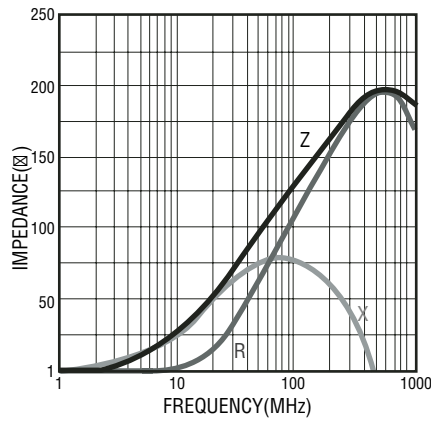

**MH 4532- 681Y**

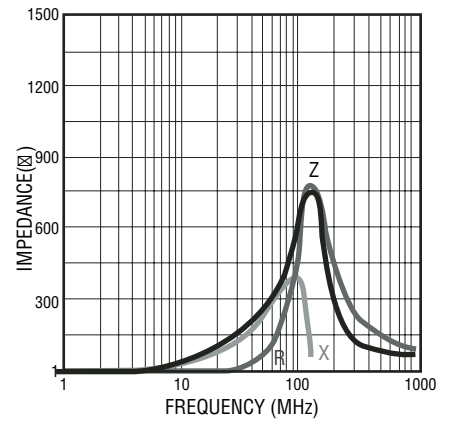

**MH 4532- 132Y**

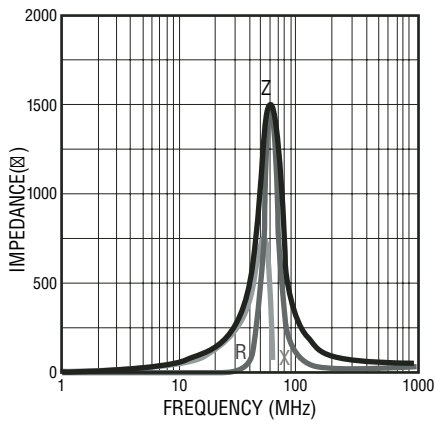

**MH 4516- 600Y**

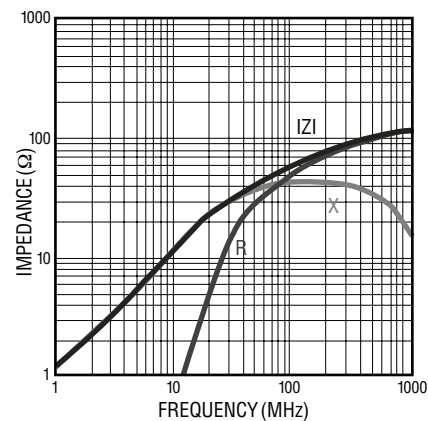

**MH 4516- 750Y**

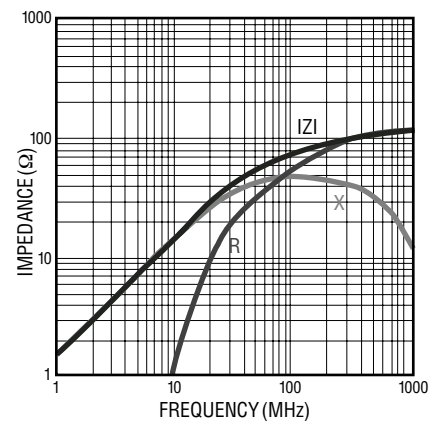

Specifications are subject to change without notice.  
Customers should verify actual device performance in their specific applications.

# MH Series High Current Chip Ferrite Beads

**BOURNS®**

## Electrical Specifications (continued)

**MH 4516- 800Y**

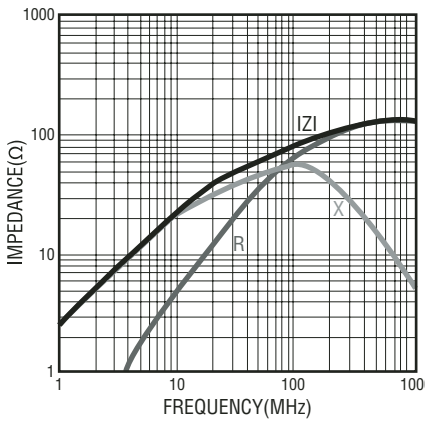

**MH 4516- 101Y**

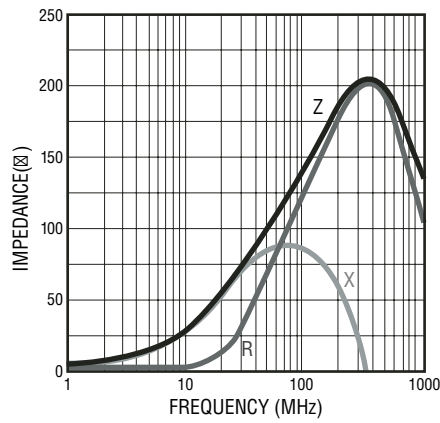

**MH 4516- 102Y**

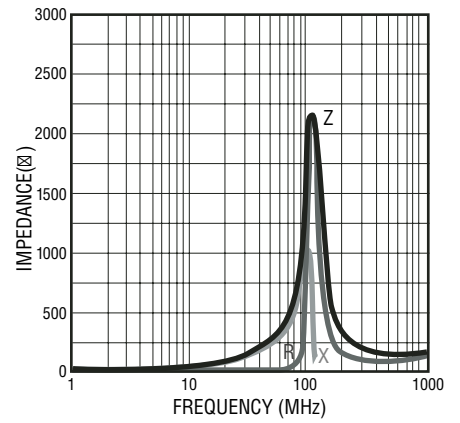

**MH 3261- 190Y**

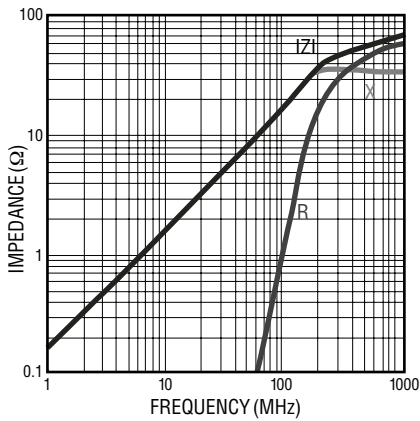

**MH 3261- 260Y**

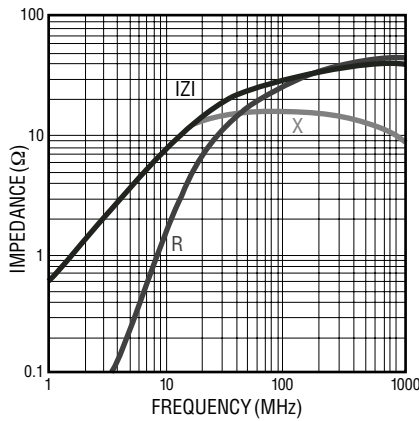

**MH 3261- 310Y**

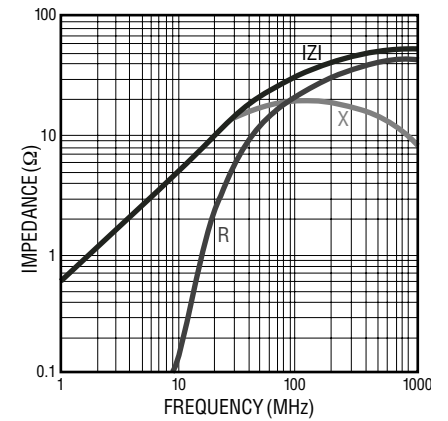

**MH 3261- 500Y**

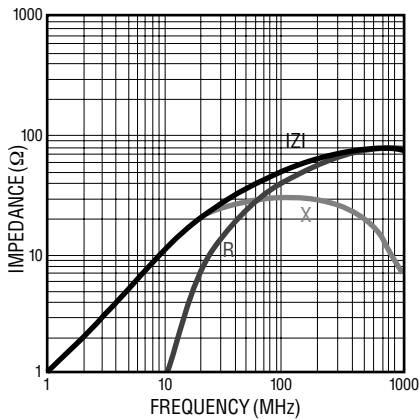

**MH 3261- 700Y**

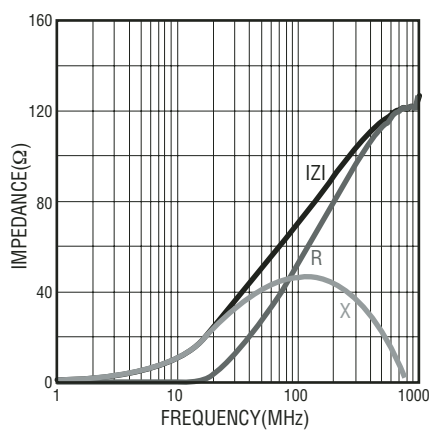

**MH 3261- 800Y**

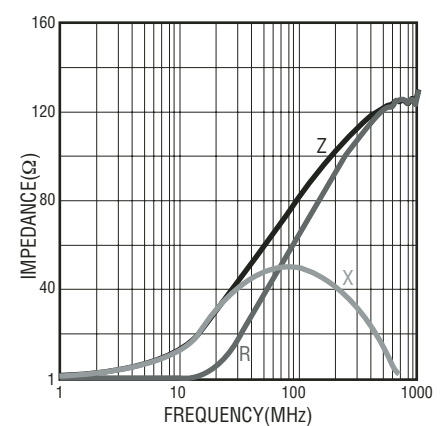

Specifications are subject to change without notice. Customers should verify actual device performance in their specific applications.

# MH Series High Current Chip Ferrite Beads

**BOURNS®**

## Electrical Specifications (continued)

**MH 3261- 900Y**

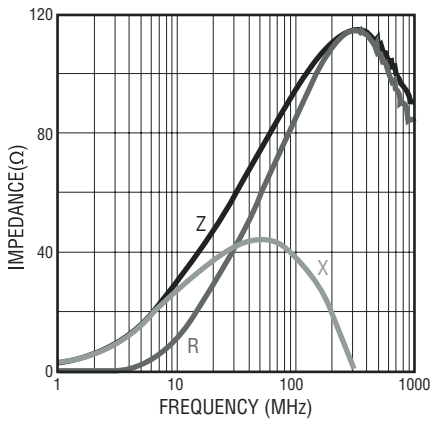

**MH 3261- 101Y**

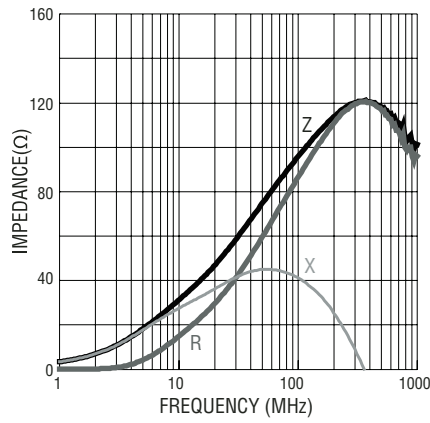

**MH 3261- 121Y**

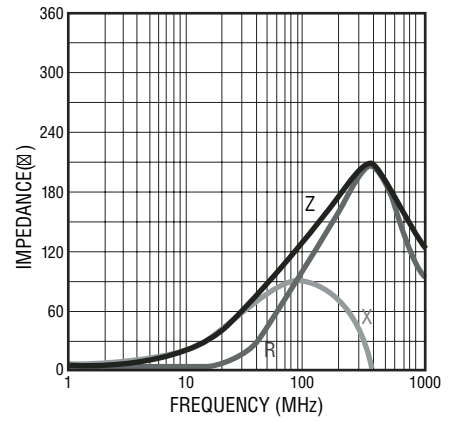

**MH 3261- 151Y**

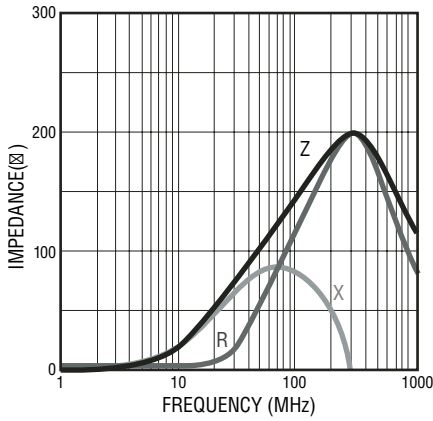

**MH 3261- 301Y**

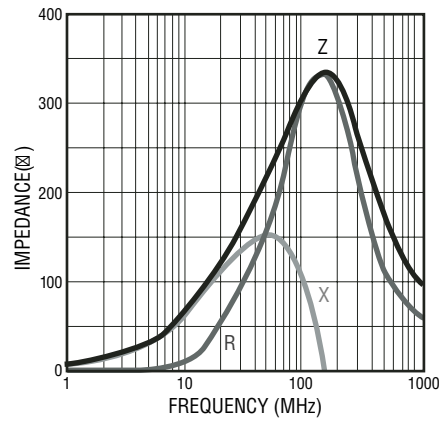

**MH 3261- 471Y**

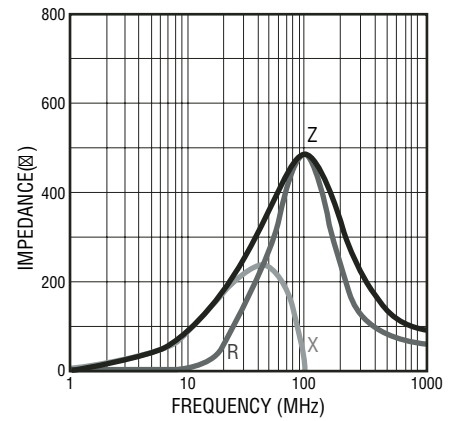

**MH 3261- 501Y**

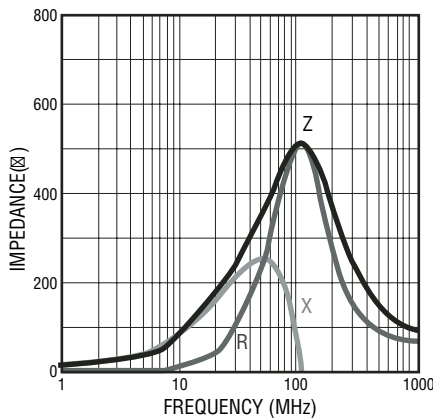

**MH 3261- 601Y**

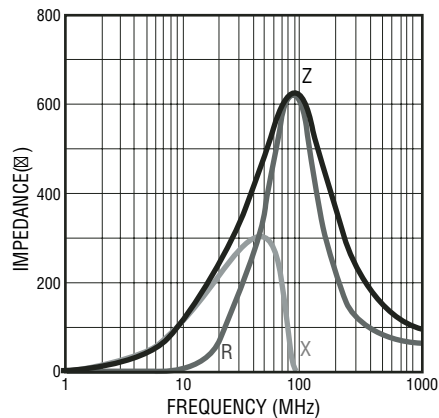

**MH 3225- 300Y**

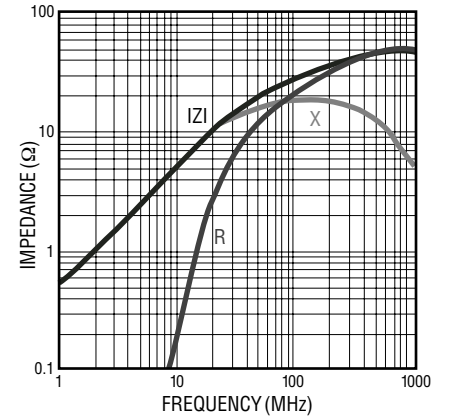

Specifications are subject to change without notice.  
Customers should verify actual device performance in their specific applications.

# MH Series High Current Chip Ferrite Beads

**BOURNS®**

## Electrical Specifications (continued)

**MH 3225- 520Y**

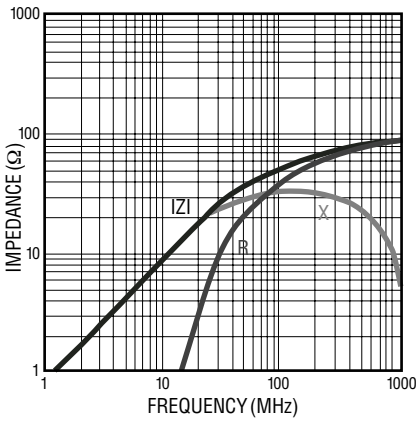

**MH 3225- 650Y**

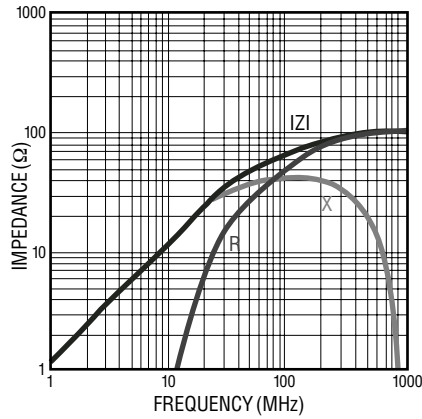

**MH 3225- 900Y**

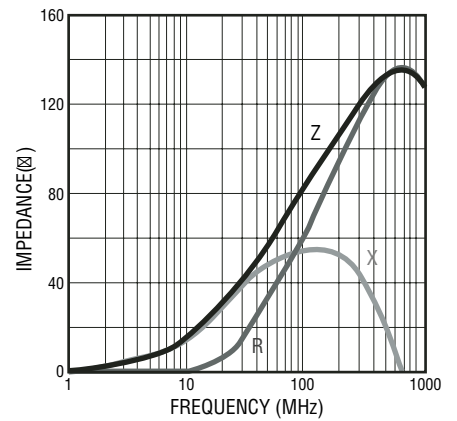

**MH 3225- 151Y**

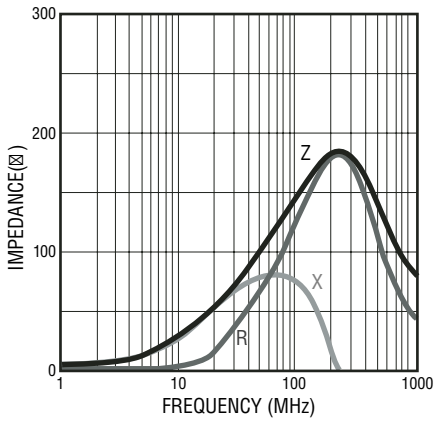

**MH 3225- 201Y**

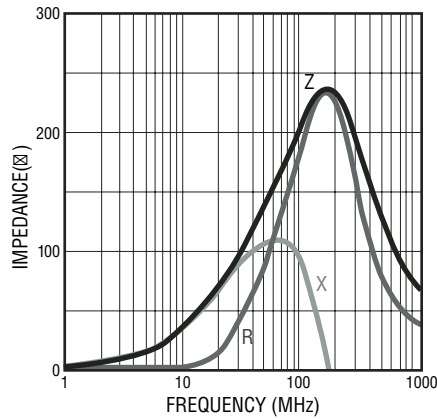

**MH 2029- 070Y**

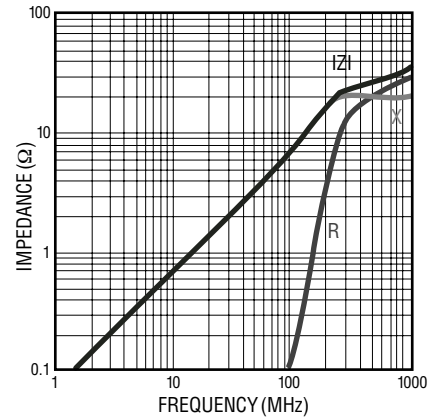

**MH 2029- 100Y**

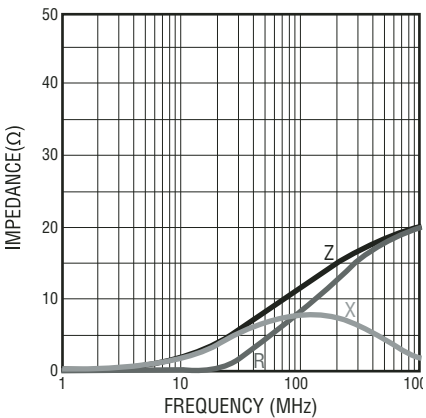

**MH 2029- 300Y**

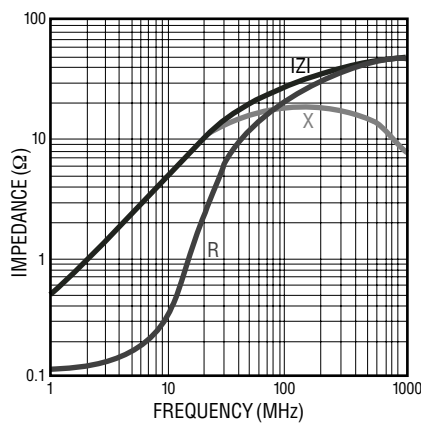

**MH 2029 -400Y**

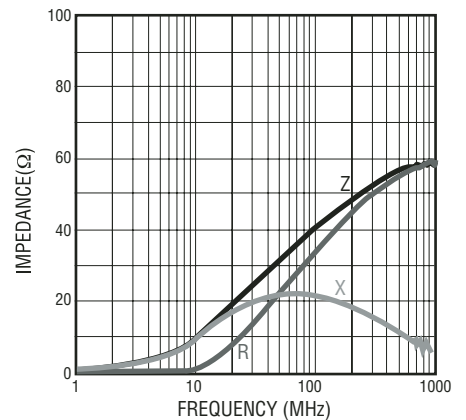

Specifications are subject to change without notice. Customers should verify actual device performance in their specific applications.

# MH Series High Current Chip Ferrite Beads

**BOURNS®**

## Electrical Specifications (continued)

**MH 2029 -600Y**

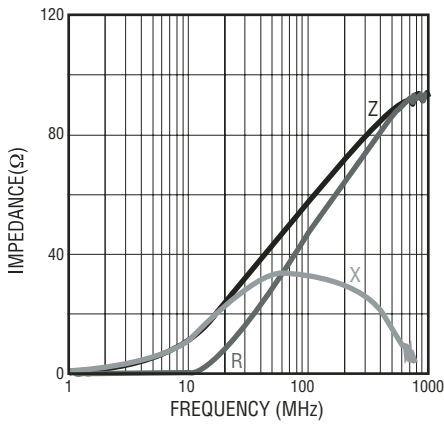

**MH 2029- 800Y**

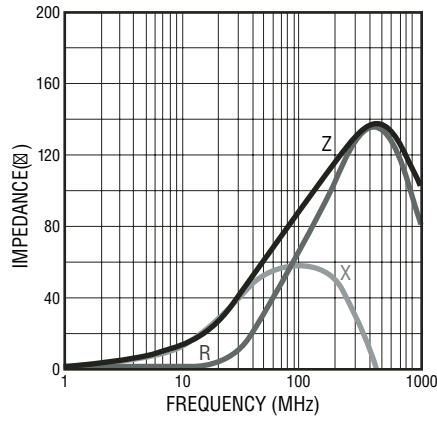

**MH 2029- 101Y**

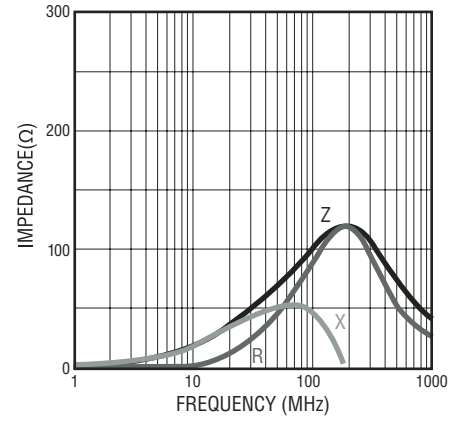

**MH 2029- 121Y**

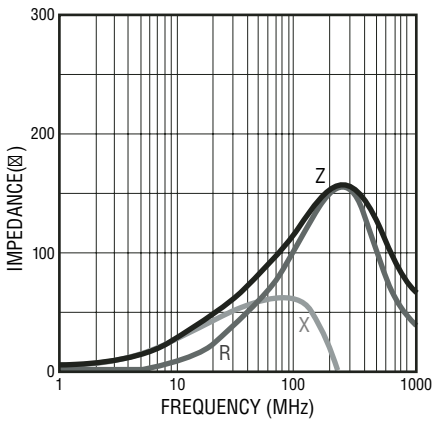

**MH 2029- 151Y**

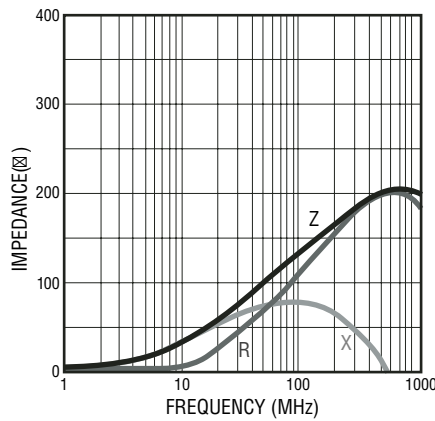

**MH 2029- 221Y**

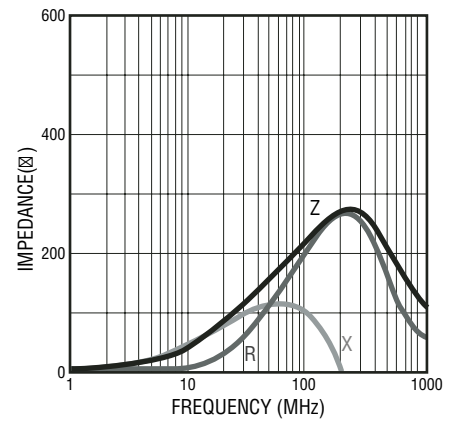

**MH 2029- 301Y**

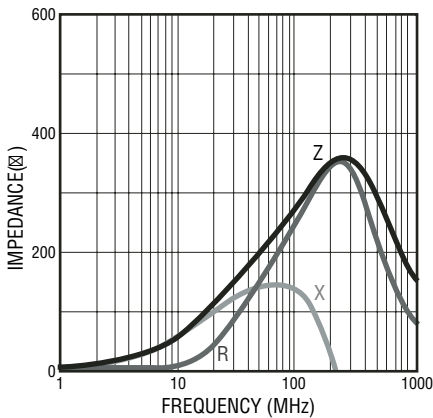

**MH 2029 -401Y**

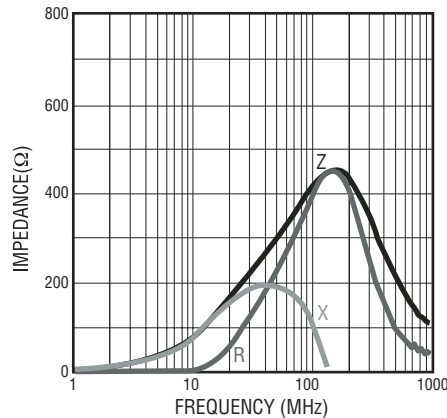

**MH 2029- 471Y**

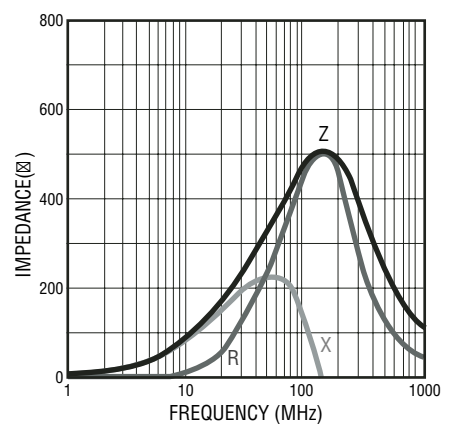

Specifications are subject to change without notice.  
Customers should verify actual device performance in their specific applications.

# MH Series High Current Chip Ferrite Beads

**BOURNS®**

## Electrical Specifications (continued)

**MH 2029- 601Y**

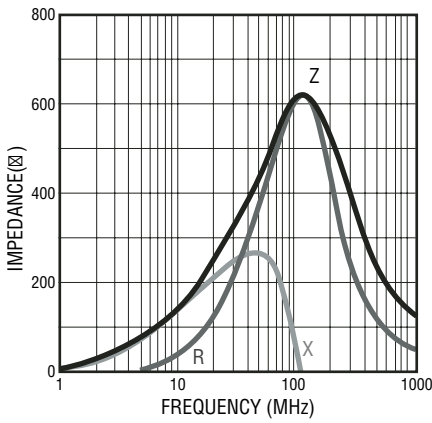

**MH 1608 -100Y**

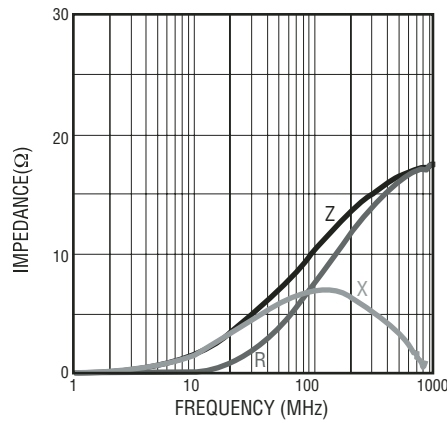

**MH 1608- 300Y**

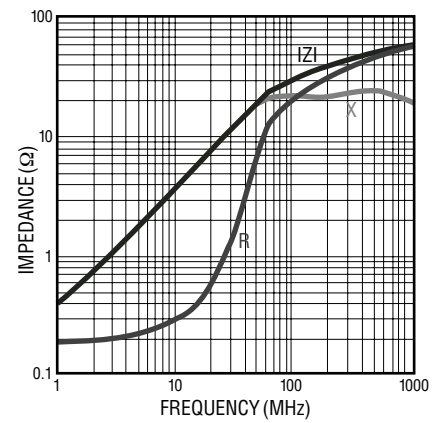

**MH 1608 -600Y**

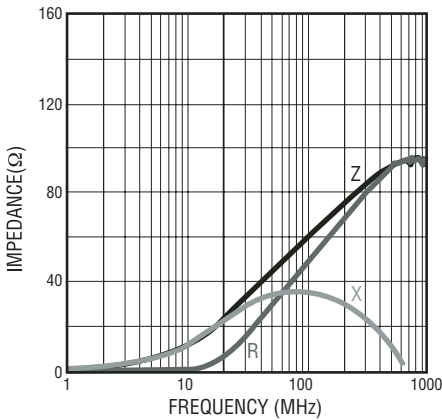

**MH 1608- 800Y**

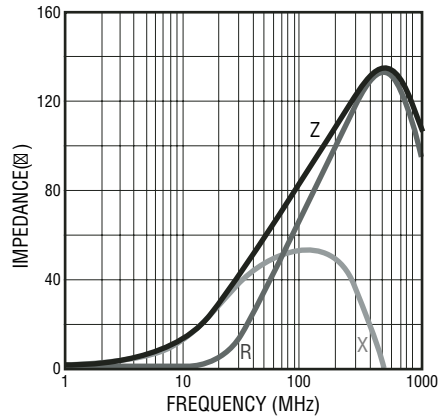

**MH 1608- 101Y**

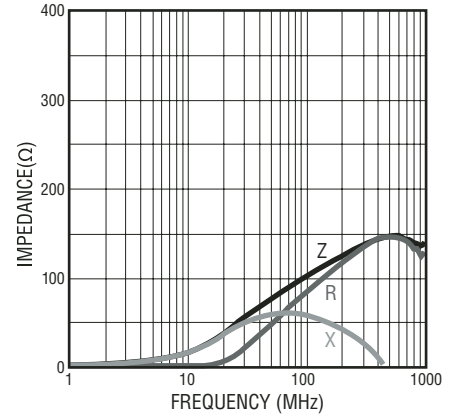

**MH 1608- 121Y**

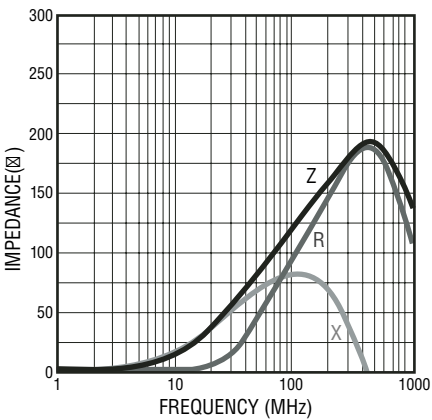

**MH 1608- 151Y**

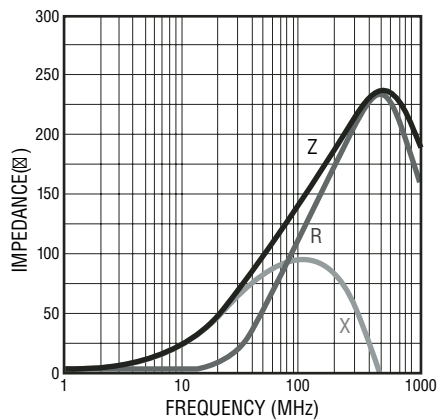

**MH 1608- 221Y**

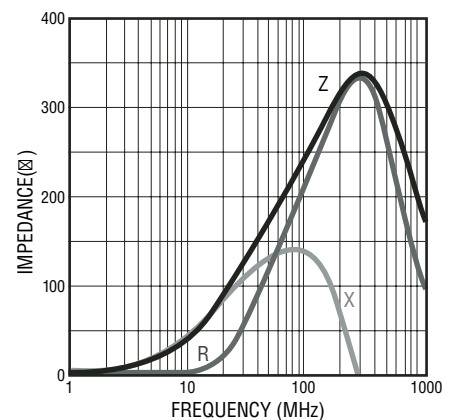

Specifications are subject to change without notice. Customers should verify actual device performance in their specific applications.



# MH Series High Current Chip Ferrite Beads

**BOURNS®**

## Electrical Specifications (continued)

**MH 1608- 301Y**

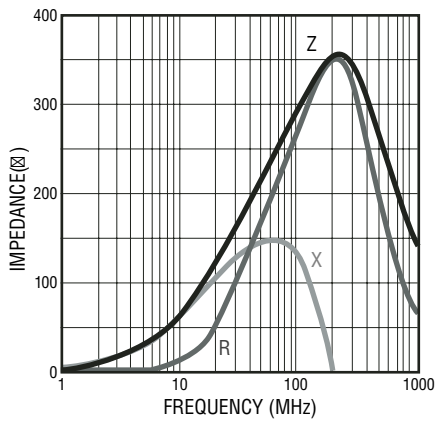

**MH 1608- 471Y**

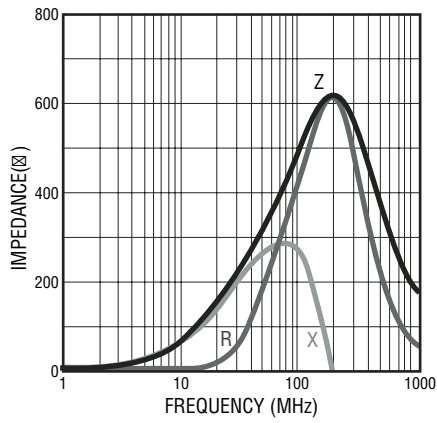

**MH 1608- 601Y**

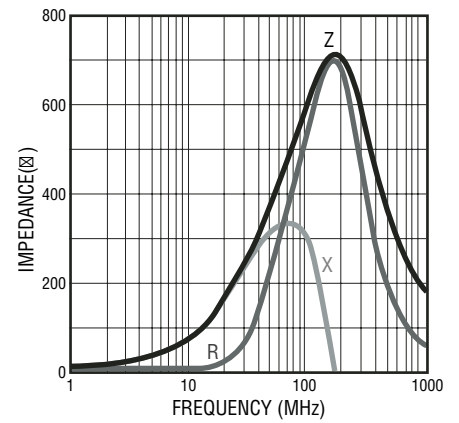

## Equivalent Circuit

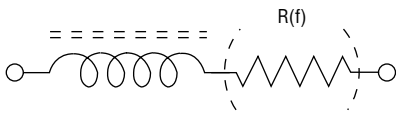

## Recommended Soldering

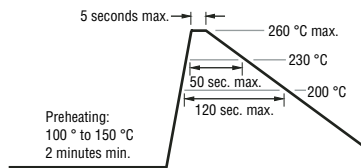

# MH Series High Current Chip Ferrite Beads

**BOURNS®**

## Product Dimensions

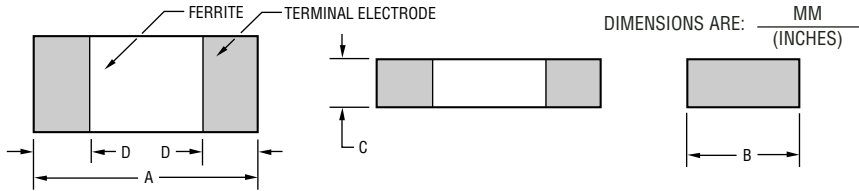

## Recommended Land Pattern

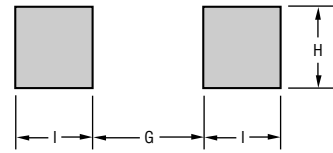

Series	A	B	C	D	G	H	I
4532	$\frac{4.5 \pm 0.2}{(.177 \pm .008)}$	$\frac{3.2 \pm 0.2}{(.126 \pm .008)}$	$\frac{1.5 \pm 0.2}{(.059 \pm .008)}$	$\frac{0.5 \pm 0.2}{(.020 \pm .008)}$	$\frac{3.0}{(.118)}$	$\frac{3.0}{(.118)}$	$\frac{1.5}{(.059)}$
4516	$\frac{4.5 \pm 0.2}{(.177 \pm .008)}$	$\frac{1.6 \pm 0.2}{(.063 \pm .008)}$	$\frac{1.6 \pm 0.2}{(.063 \pm .008)}$	$\frac{0.5 \pm 0.2}{(.020 \pm .008)}$	$\frac{3.0}{(.118)}$	$\frac{1.4}{(.055)}$	$\frac{1.5}{(.059)}$
3261	$\frac{3.2 \pm 0.2}{(.126 \pm .008)}$	$\frac{1.6 \pm 0.2}{(.063 \pm .008)}$	$\frac{1.1 \pm 0.2}{(.043 \pm .008)}$	$\frac{0.5 \pm 0.2}{(.020 \pm .008)}$	$\frac{2.0}{(.079)}$	$\frac{1.4}{(.053)}$	$\frac{1.1}{(.043)}$
3225	$\frac{3.2 \pm 0.2}{(.126 \pm .008)}$	$\frac{2.5 \pm 0.2}{(.098 \pm .008)}$	$\frac{1.3 \pm 0.2}{(.051 \pm .008)}$	$\frac{0.5 \pm 0.2}{(.020 \pm .008)}$	$\frac{2.2}{(.118)}$	$\frac{2.3}{(.091)}$	$\frac{1.1}{(.043)}$
2029	$\frac{2.0 \pm 0.2}{(.079 \pm .008)}$	$\frac{1.2 \pm 0.2}{(.047 \pm .008)}$	$\frac{0.9 \pm 0.2}{(.035 \pm .008)}$	$\frac{0.5 \pm 0.2}{(.020 \pm .008)}$	$\frac{1.0}{(.040)}$	$\frac{1.0}{(.040)}$	$\frac{1.0}{(.040)}$
1608	$\frac{1.6 \pm 0.2}{(.063 \pm .008)}$	$\frac{0.8 \pm 0.2}{(.031 \pm .008)}$	$\frac{0.8 \pm 0.2}{(.031 \pm .008)}$	$\frac{0.5 \pm 0.2}{(.020 \pm .008)}$	$\frac{0.7}{(.028)}$	$\frac{0.7}{(.128)}$	$\frac{0.7}{(.128)}$

## Reel Dimensions

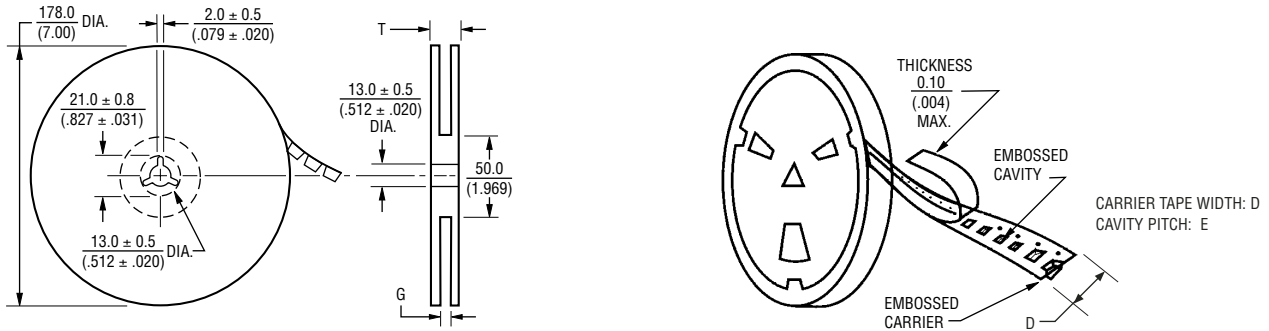

Series	Pcs. per Reel	Gross Weight (g)	D	E	G	T
4532	1,000	170	$\frac{12.0}{(.472)}$	$\frac{8.0}{(.315)}$	$\frac{14.0 + 0}{(.551 + 0)}$	$\frac{16.5}{(.650)}$
4516	2,000	180	$\frac{12.0}{(.472)}$	$\frac{8.0}{(.315)}$	$\frac{14.0 + 0}{(.551 + 0)}$	$\frac{16.5}{(.650)}$
3261	3,000	150	$\frac{8.0}{(.315)}$	$\frac{4.0}{(.157)}$	$\frac{10.0 + 0}{(.394 + 0)}$	$\frac{12.5}{(.492)}$
3225	2,500	160	$\frac{8.0}{(.315)}$	$\frac{4.0}{(.157)}$	$\frac{10.0 + 0}{(.394 + 0)}$	$\frac{12.5}{(.492)}$
2029	4,000	120	$\frac{8.0}{(.315)}$	$\frac{4.0}{(.157)}$	$\frac{10.0 + 0}{(.394 + 0)}$	$\frac{12.5}{(.492)}$
1608	4,000	90	$\frac{8.0}{(.315)}$	$\frac{4.0}{(.157)}$	$\frac{10.0 + 0}{(.394 + 0)}$	$\frac{12.5}{(.492)}$

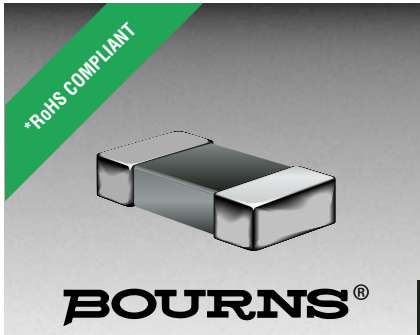

## Features

- High resistance to heat and humidity
- Resistance to mechanical shock and pressure
- Accurate dimensions for automatic surface mounting
- Wide impedance range

## Applications

- Power supply lines
- IC power lines
- Signal lines

# MG, MU, MZ Series High Impedance Chip Ferrite Beads

### Electrical Specifications

Model Number	Impedance (Ω) at 100 MHz	RDC (Ω) Max.	IDC (mA) Max.
MU3261-300Y	30 ±25 %	0.20	500
MU3261-600Y	60 ±25 %	0.20	400
MU3261-750Y	75 ±25 %	0.20	400
MU3261-101Y	100 ±25 %	0.15	500
MU3261-121Y	120 ±25 %	0.15	900
MG3261-151Y	150 ±25 %	0.30	300
MU3261-221Y	220 ±25 %	0.35	700
MG3261-301Y	300 ±25 %	0.30	300
MU3261-301Y	300 ±25 %	0.30	300
MU3261-471Y	470 ±25 %	0.35	400
MU3261-601Y	600 ±25 %	0.30	200
MZ3261-601Y	600 ±25 %	0.30	200
MU3261-801Y	800 ±25 %	0.60	300
MU3261-102Y	1000 ±25 %	0.60	100
MZ3261-122Y	1200 ±25 % (at 50 MHz)	0.50	100
MU3261-122Y	1200 ±25 % (at 50 MHz)	0.50	100
MU3261-152Y	1500 ±25 % (at 50 MHz)	0.70	300
MZ3261-202Y	2000 ±25 % (at 30 MHz)	0.60	100
MU3261-202Y	2000 ±25 % (at 30 MHz)	0.60	100
MG2029-100Y	10 ±25 %	0.20	400
MG2029-300Y	30 ±25 %	0.10	400
MG2029-400Y	40 ±25 %	0.20	300
MU2029-600Y	60 ±25 %	0.10	900
MG2029-800Y	80 ±25%	0.20	300
MG2029-101Y	100 ±25 %	0.20	400
MG2029-121Y	120 ±25 %	0.25	300
MU2029-151Y	150 ±25 %	0.20	800
MU2029-221Y	220 ±25 %	0.30	500
MU2029-301Y	300 ±25 %	0.30	500
MU2029-471Y	470 ±25 %	0.35	700
MZ2029-601Y	600 ±25 %	0.40	100
MZ2029-601T	600 ±25 %	0.40	200
MZ2029-102Y	1000 ±25 %	0.45	100
MZ2029-152Y	1500 ±25 %	0.55	100
MZ2029-202Y	2000 ±25 %	0.60	50
MG1608-300Y	30 ±25 %	0.20	200
MG1608-400Y	40 ±25 %	0.30	300
MU1608-600Y	60 ±25 %	0.20	700
MG1608-800Y	80 ±25 %	0.30	300
MG1608-101Y	100 ±25 %	0.25	200
MG1608-121Y	120 ±25 %	0.30	200
MU1608-151Y	150 ±25 %	0.25	600
MU1608-221Y	220 ±25 %	0.30	200
MU1608-301Y	300 ±25 %	0.35	150
MU1608-471Y	470 ±25 %	0.45	350
MZ1608-601Y	600 ±25 %	0.45	100
MZ1608-102Y	1000 ±25 %	0.60	100
MZ1608-152Y	1500 ±25 %	0.70	50
MG1608-202Y	2000 ±25 %	0.80	50
MG1608-222Y	2200 ±25 %	1.50	200
MU1005-100Y	10 ±25 %	0.10	500
MU1005-300Y	30 ±25 %	0.20	300
MU1005-600Y	60 ±25 %	0.25	300
MU1005-121Y	120 ±25 %	0.30	100
MU1005-151Y	150 ±25 %	0.30	100
MU1005-221Y	220 ±25 %	0.40	100
MU1005-241Y	240 ±25 %	0.60	100
MU1005-301Y	300 ±25 %	0.50	100
MU1005-471Y	470 ±25 %	0.65	100
MU1005-601Y	600 ±25 %	0.80	80
MU1005-102Y	1000 ±25 %	1.20	80

### General Specifications

Operating Temperature .....-55 °C to +125 °C  
 Storage Temperature ..-55 °C to +125 °C  
 Storage Condition .....+40 °C max. at 70 % RH  
 Reflow Soldering .....230 °C, 50 seconds max.  
 Resistance to Soldering Heat .....260 °C, 5 seconds  
 Rated Current .....Based on max. temperature rise of +40 °C  
 Terminal Strength (Force "F" applied for 30 seconds)  
 3261 Series .....1.0 F (Kg)  
 2029 Series .....0.6 F (Kg)  
 1608 Series .....0.5 F (Kg)

### Materials

Core Material .....Ferrite  
 Internal Conductor .....Ag or Ag/Pd  
 Terminal .....Ag/Ni/Sn

\*RoHS Directive 2002/95/EC Jan 27 2003 including Annex  
 Specifications are subject to change without notice.  
 Customers should verify actual device performance in their specific applications.

# MG, MU, MZ Series High Impedance Chip Ferrite Beads

**BOURNS®**

## Electrical Specifications (continued)

**MU 3261- 300Y**

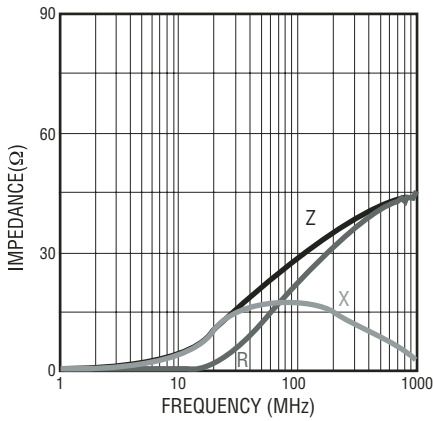

**MU 3261- 600Y**

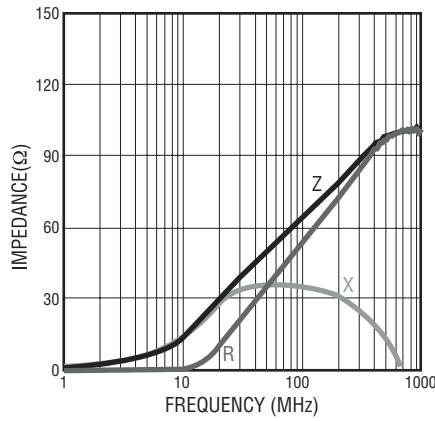

**MU 3261- 750Y**

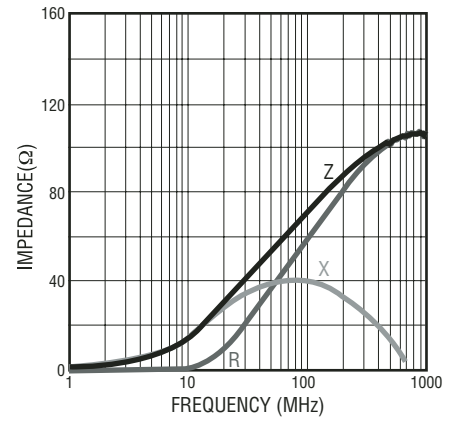

**MU 3261- 101Y**

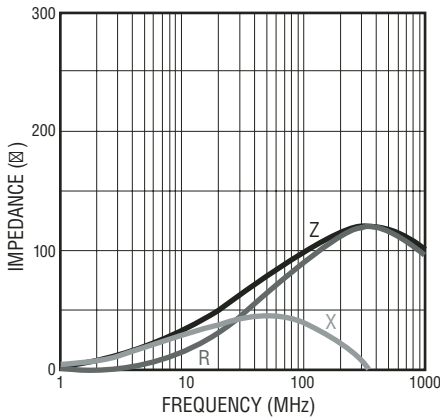

**MU 3261- 121Y**

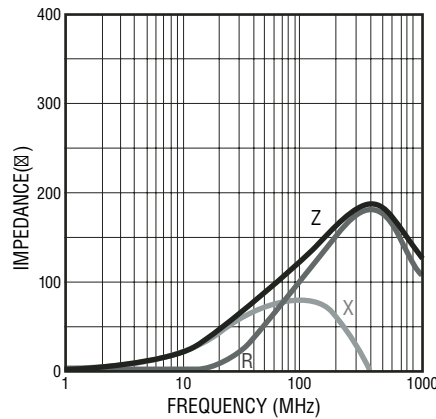

**MG 3261- 151Y**

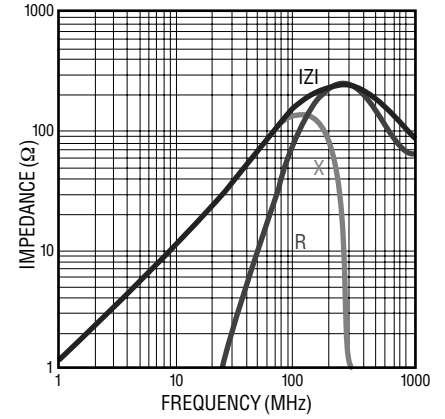

**MU 3261- 221Y**

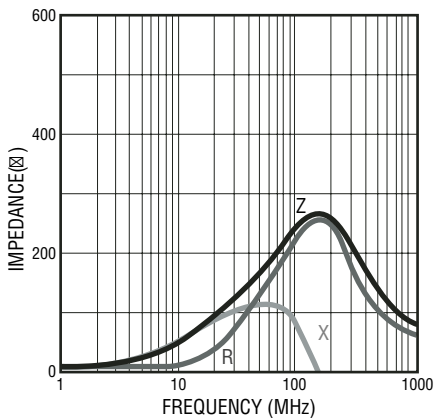

**MG 3261- 301Y**

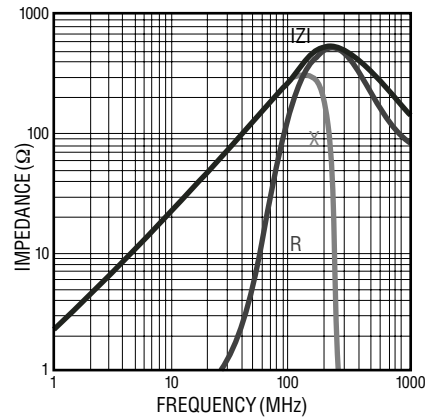

**MU 3261- 301Y**

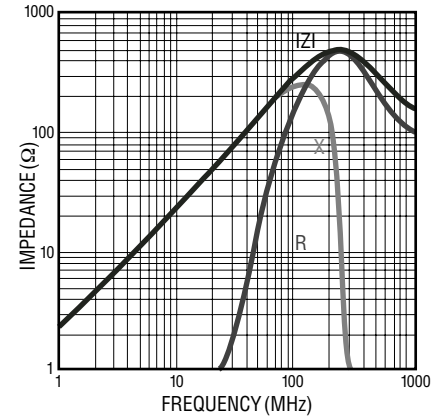

Specifications are subject to change without notice. Customers should verify actual device performance in their specific applications.

# MG, MU, MZ Series High Impedance Chip Ferrite Beads

**BOURNS®**

## Electrical Specifications (continued)

**MU 3261- 471Y**

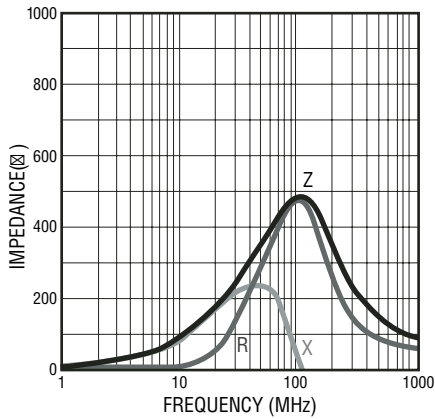

**MU 3261- 601Y**

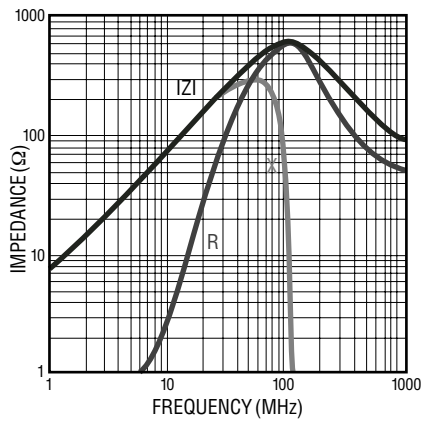

**MZ 3261- 601Y**

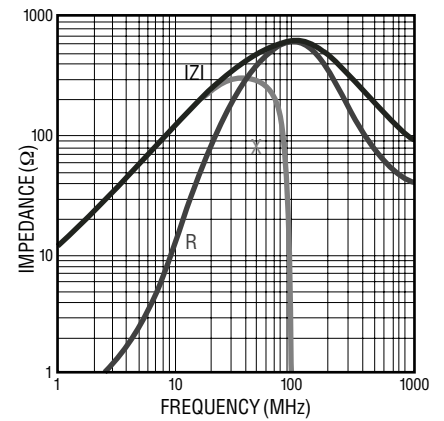

**MU 3261- 801Y**

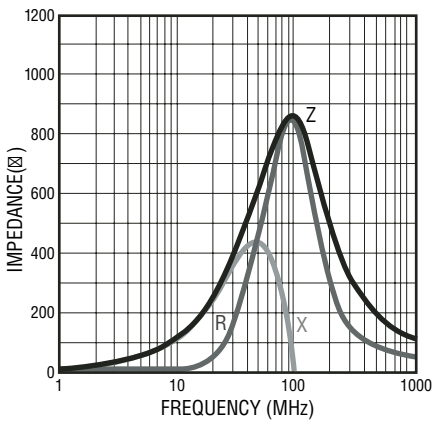

**MZ 3261- 122Y**

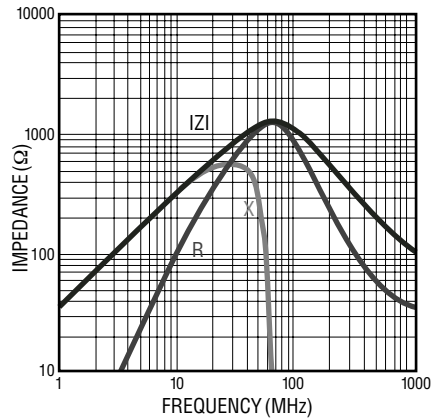

**MU 3261- 102Y**

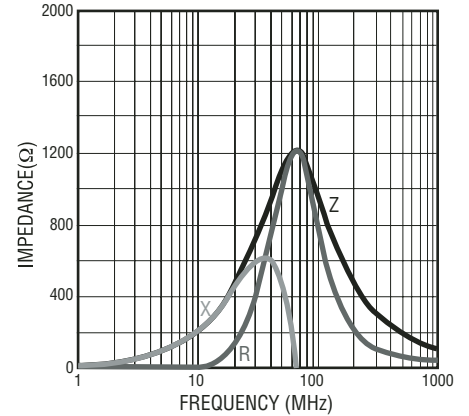

**MU 3261- 122Y**

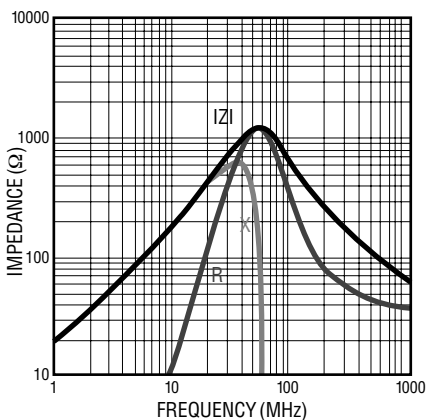

**MU 3261- 152Y**

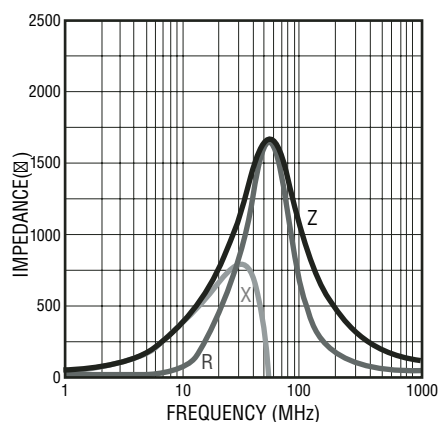

**MZ 3261- 202Y**

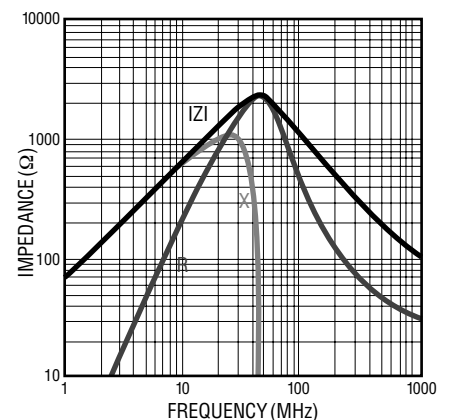

Specifications are subject to change without notice.  
Customers should verify actual device performance in their specific applications.

# MG, MU, MZ Series High Impedance Chip Ferrite Beads

**BOURNS®**

## Electrical Specifications (continued)

**MU 3261- 202Y**

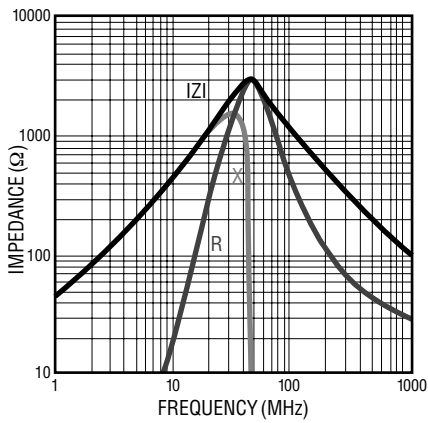

**MG 2029- 100Y**

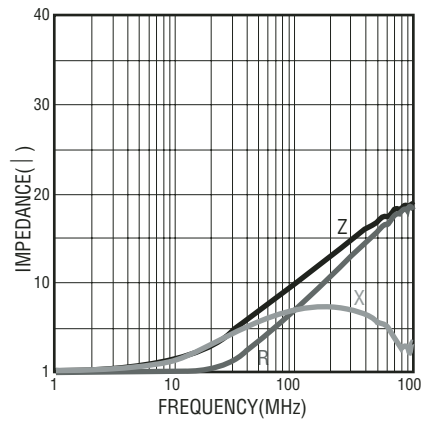

**MG 2029- 300Y**

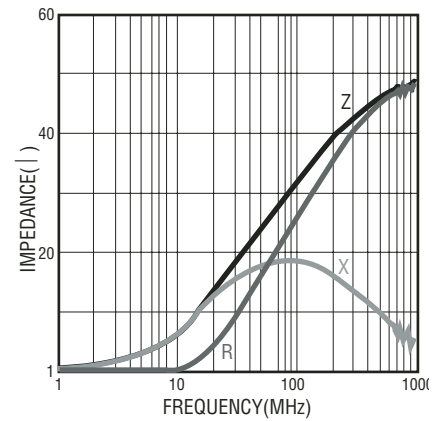

**MG 2029- 400Y**

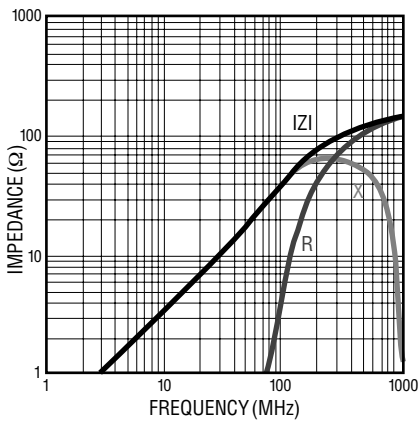

**MU 2029- 600Y**

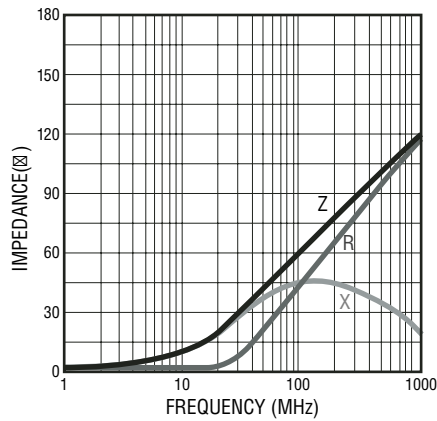

**MG 2029- 800Y**

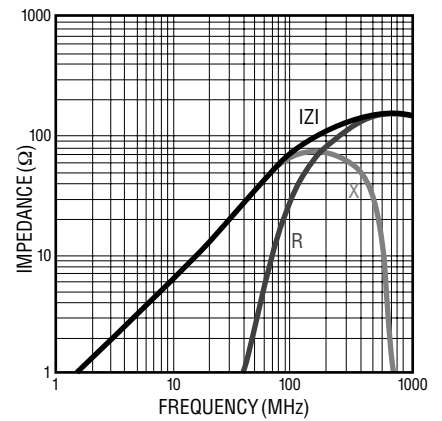

**MG 2029- 101Y**

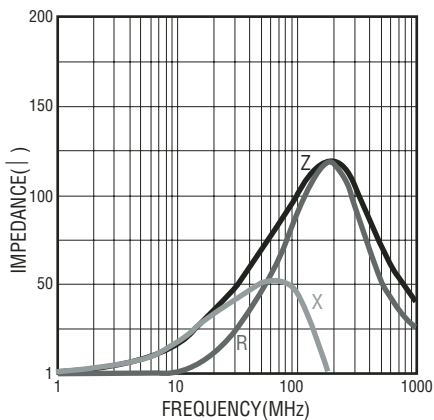

**MG 2029- 121Y**

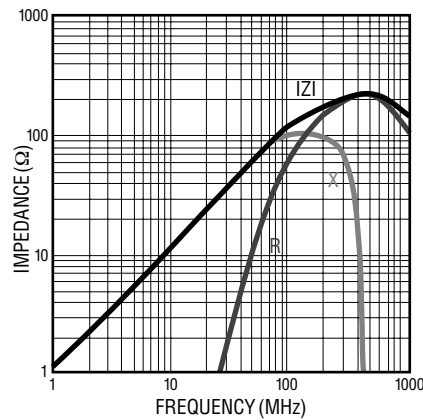

**MU 2029- 151Y**

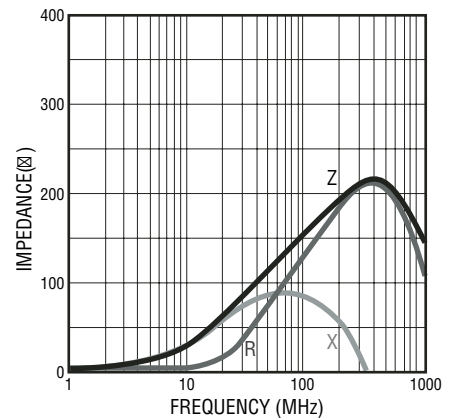

Specifications are subject to change without notice. Customers should verify actual device performance in their specific applications.

# MG, MU, MZ Series High Impedance Chip Ferrite Beads

**BOURNS®**

## Electrical Specifications (continued)

**MU 2029- 221Y**

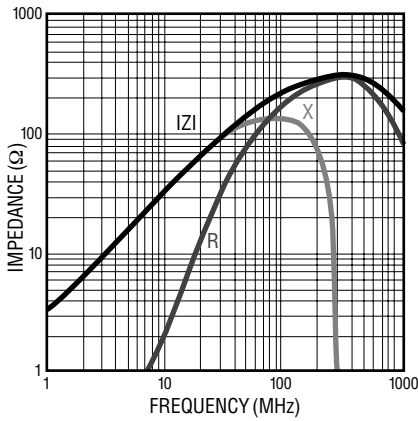

**MU 2029- 301Y**

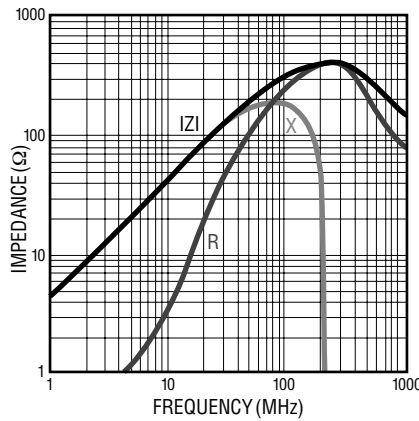

**MU 2029- 471Y**

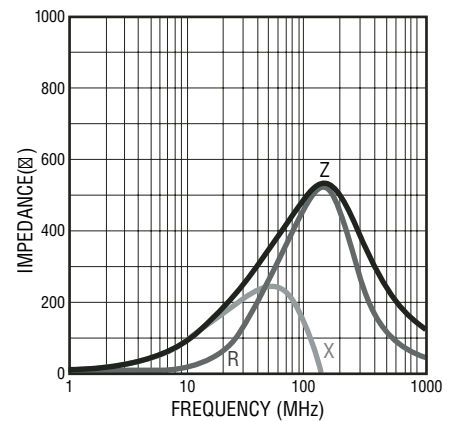

**MZ 2029- 601Y**

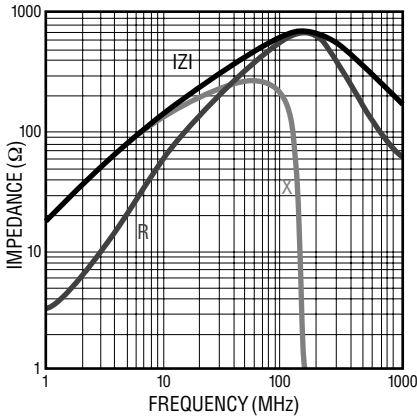

**MZ 2029- 102Y**

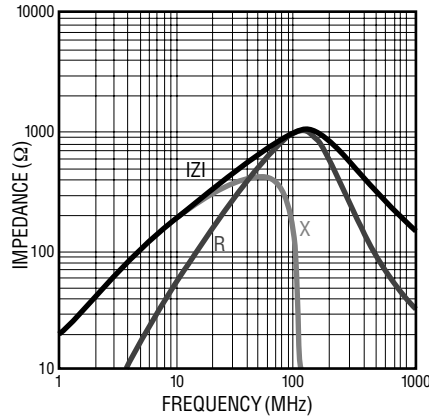

**MG 2029- 152Y**

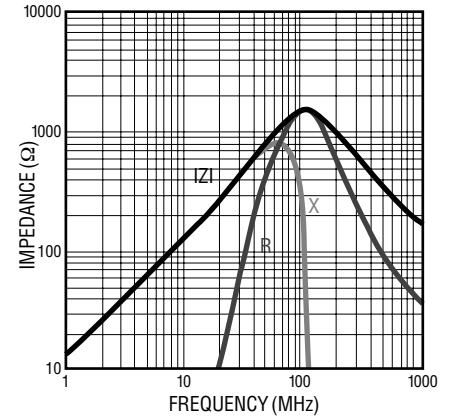

**MG 2029- 202Y**

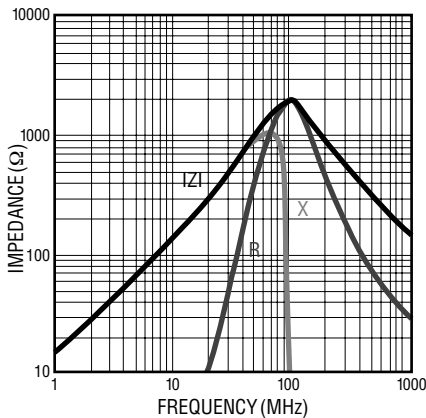

**MU 1608- 300Y**

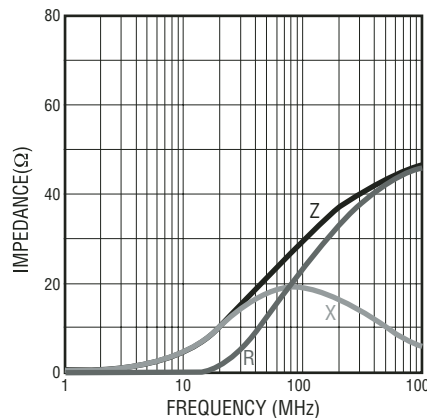

**MG 1608- 400Y**

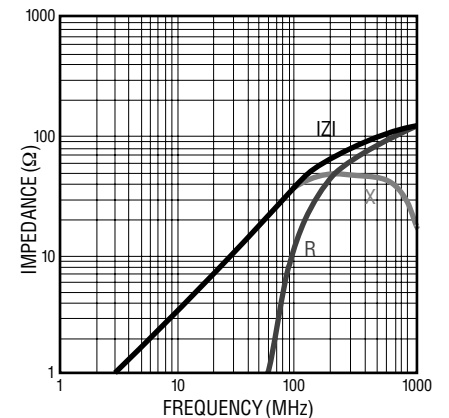

Specifications are subject to change without notice.  
Customers should verify actual device performance in their specific applications.

# MG, MU, MZ Series High Impedance Chip Ferrite Beads

**BOURNS®**

## Electrical Specifications (continued)

**MU 1608- 600Y**

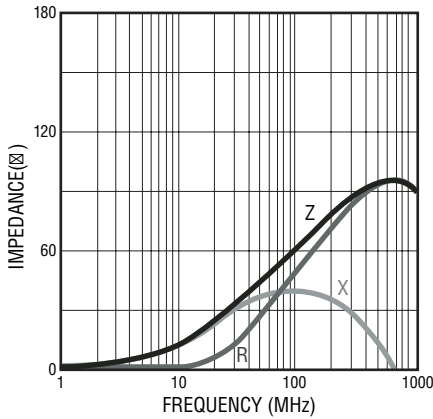

**MG 1608- 800Y**

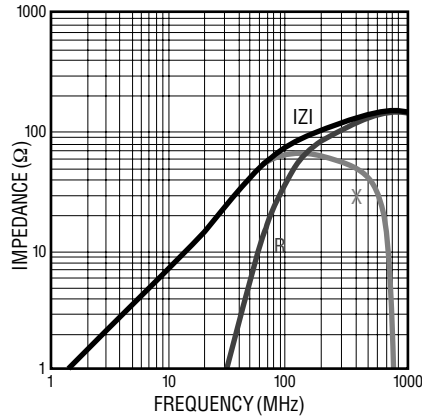

**MU 1608- 101Y**

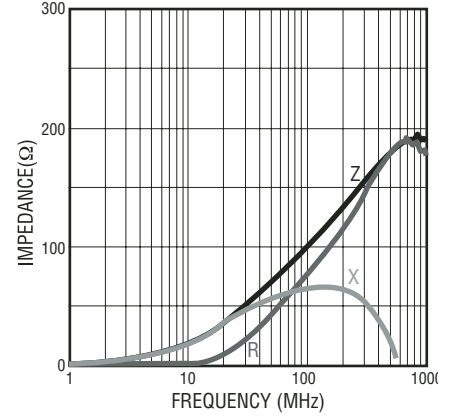

**MG 1608- 121Y**

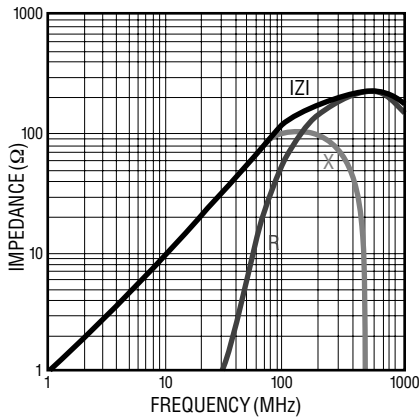

**MU 1608- 151Y**

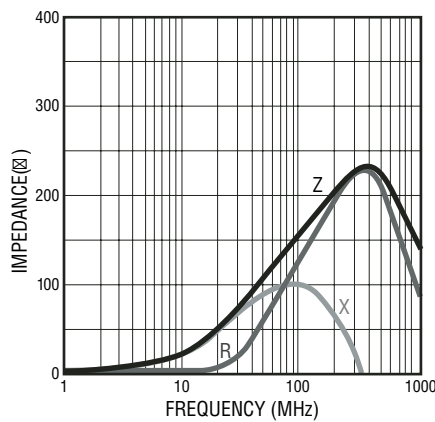

**MU 1608- 221Y**

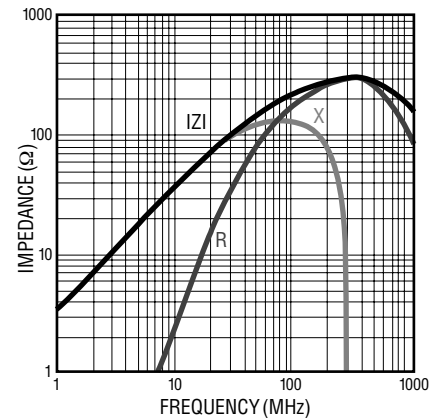

**MU 1608- 301Y**

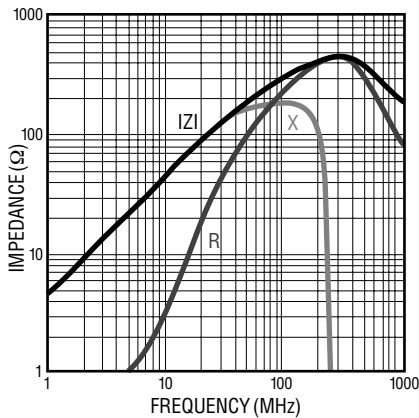

**MU 1608- 471Y**

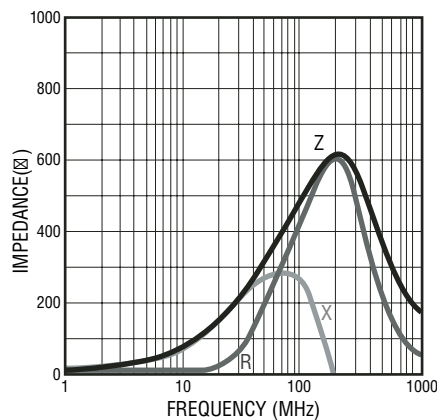

**MZ 1608- 601Y**

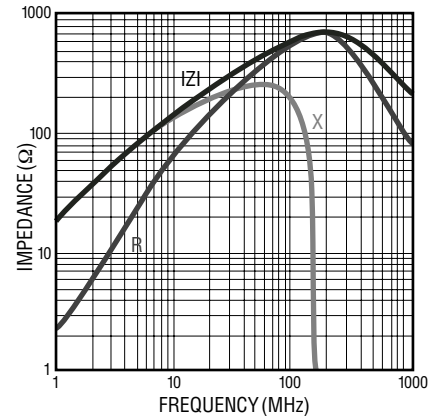



# MG, MU, MZ Series High Impedance Chip Ferrite Beads

**BOURNS®**

## Electrical Specifications (continued)

**MZ 1608- 102Y**

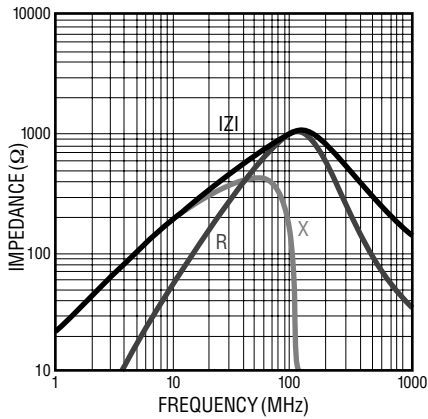

**MG 1608- 152Y**

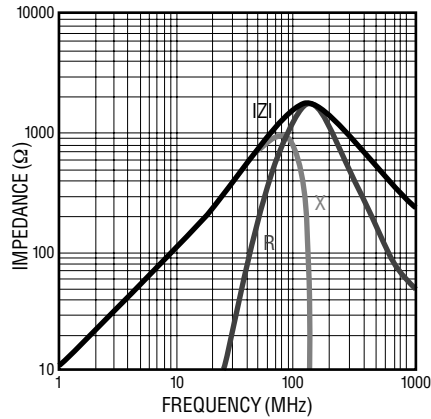

**MG 1608- 202Y**

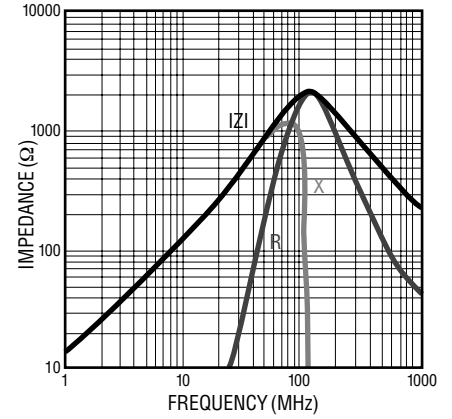

**MZ 1608- 222Y**

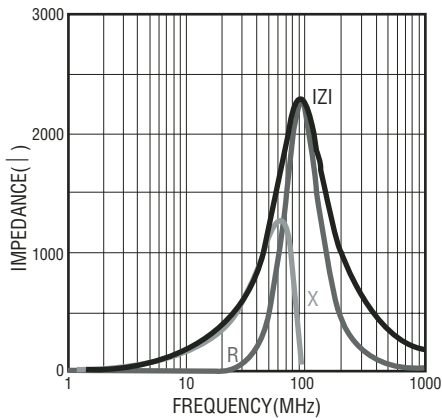

**MU 1005- 100Y**

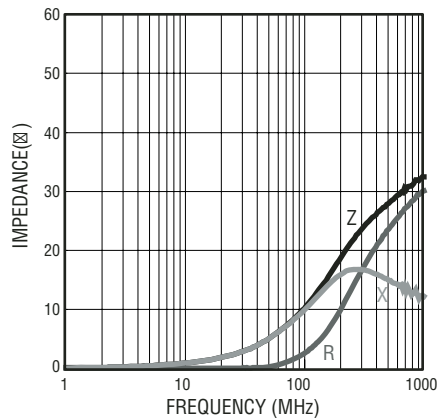

**MU 1005- 300Y**

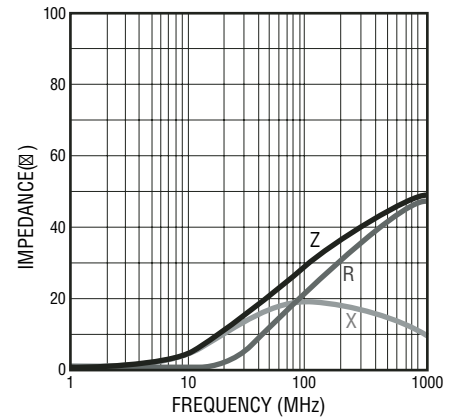

**MU 1005- 600Y**

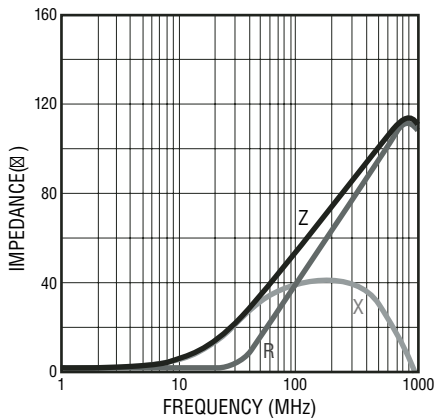

**MU 1005- 121Y**

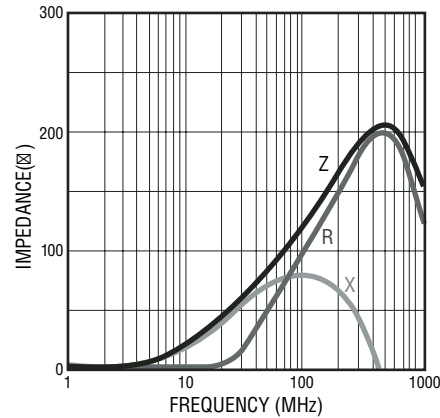

**MU 1005- 151Y**

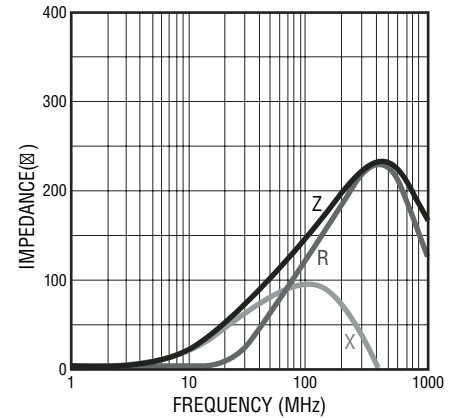

Specifications are subject to change without notice.  
Customers should verify actual device performance in their specific applications.

# MG, MU, MZ Series High Impedance Chip Ferrite Beads

**BOURNS®**

## Electrical Specifications (continued)

**MU 1005- 221Y**

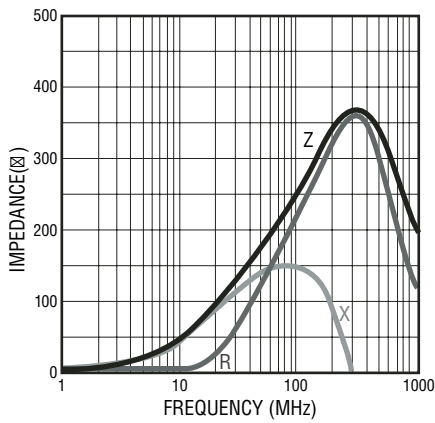

**MU 1005- 241Y**

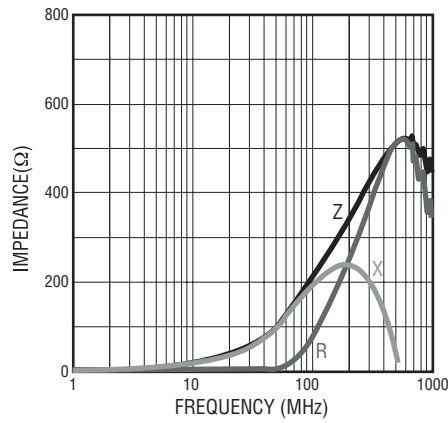

**MU 1005- 301Y**

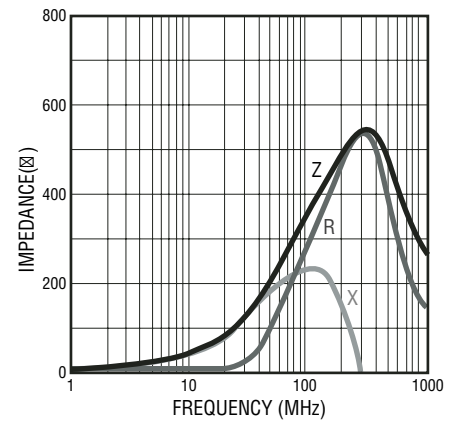

**MU 1005- 471Y**

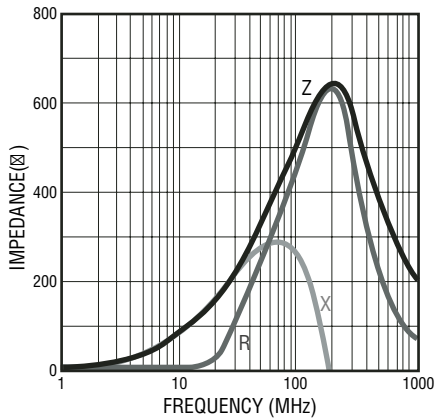

**MU 1005- 601Y**

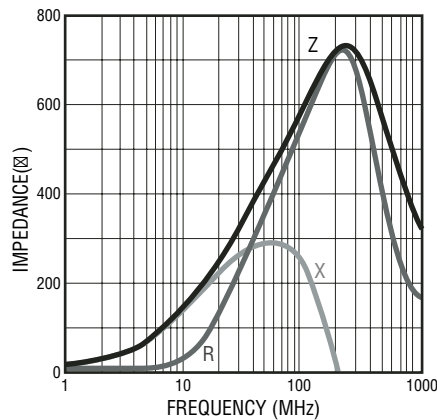

**MU 1005- 102Y**

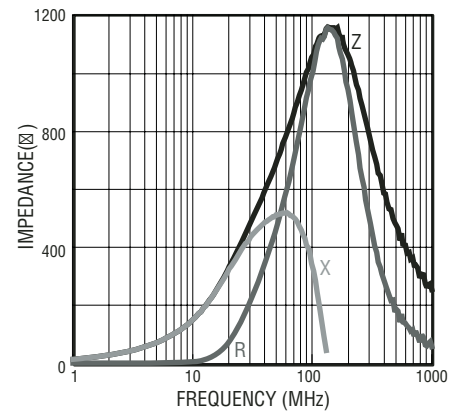

# MG, MU, MZ Series High Impedance Chip Ferrite Beads

**BOURNS®**

## Product Dimensions

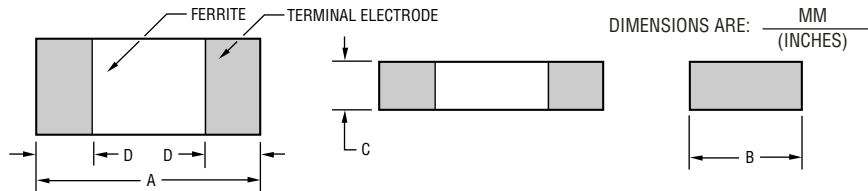

## Recommended Land Pattern

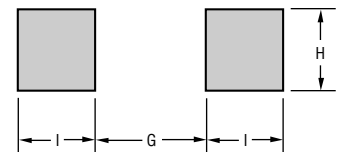

Series	A	B	C	D	G	H	I
3261	$\frac{3.2 \pm 0.2}{(.126 \pm .008)}$	$\frac{1.6 \pm 0.2}{(.063 \pm .008)}$	$\frac{1.1 \pm 0.2}{(.043 \pm .008)}$	$\frac{0.5 \pm 0.2}{(.020 \pm .008)}$	$\frac{2.0}{(.079)}$	$\frac{1.4}{(.053)}$	$\frac{1.1}{(.043)}$
2029	$\frac{2.0 \pm 0.2}{(.079 \pm .008)}$	$\frac{1.2 \pm 0.2}{(.047 \pm .008)}$	$\frac{0.9 \pm 0.2}{(.035 \pm .008)}$	$\frac{0.5 \pm 0.2}{(.020 \pm .008)}$	$\frac{1.0}{(.040)}$	$\frac{1.0}{(.040)}$	$\frac{1.0}{(.040)}$
1608	$\frac{1.6 \pm 0.2}{(.063 \pm .008)}$	$\frac{0.8 \pm 0.2}{(.031 \pm .008)}$	$\frac{0.8 \pm 0.2}{(.031 \pm .008)}$	$\frac{0.5 \pm 0.2}{(.020 \pm .008)}$	$\frac{0.7}{(.028)}$	$\frac{0.7}{(.128)}$	$\frac{0.7}{(.128)}$
1005	$\frac{1.0 \pm 0.10}{(.04 \pm .004)}$	$\frac{0.50 \pm 0.10}{(0.02 \pm .004)}$	$\frac{0.50 \pm 0.10}{(.02 \pm .004)}$	$\frac{0.25 \pm 0.10}{(.01 \pm .004)}$	$\frac{0.5}{(.02)}$	$\frac{0.55}{(.022)}$	$\frac{0.7}{(.028)}$

## Reel Dimensions

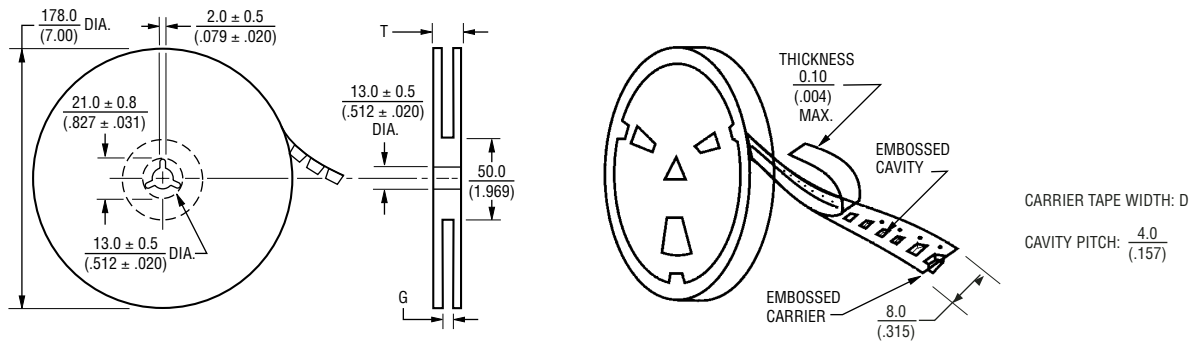

Series	Pcs. per Reel	Gross Weight (g)	D	G	T
3261	3,000	150	$\frac{8.0}{(.315)}$	$\frac{10.0 + 0}{(.394 + 0)}$	$\frac{12.5}{(.492)}$
2029	4,000	120			
1608	4,000	90			
1005	10,000	135			

## Equivalent Circuit

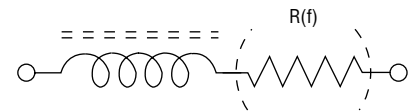

## Recommended Soldering

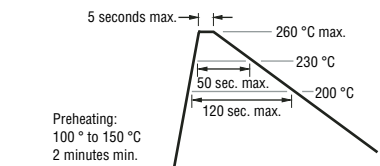

REV. 11/07

Specifications are subject to change without notice.  
Customers should verify actual device performance in their specific applications.

RoHS COMPLIANT

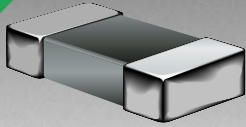

**BOURNS®**

## Features

- High resistance to heat and humidity
- Resistance to mechanical shock and pressure
- Accurate dimensions for automatic surface mounting
- Wide impedance range

## Applications

- Power supply lines
- IC power lines
- Signal lines

# MT Series Low Impedance Chip Ferrite Beads

### Electrical Specifications

Model Number	Impedance ( $\Omega$ ) at 100 MHz	RDC ( $\Omega$ ) Max.	IDC (mA) Max.
MT4532-250Y	25 $\pm$ 25 %	0.4	300
MT4532-700Y	70 $\pm$ 25 %	0.3	300
MT4532-121Y	120 $\pm$ 25 %	0.3	300
MT4532-131Y	125 $\pm$ 25 %	0.3	300
MT4516-800Y	80 $\pm$ 25 %	0.3	300
MT4516-101Y	100 $\pm$ 25 %	0.1	500
MT4516-151Y	150 $\pm$ 25 %	0.3	300
MT3225-310Y	31 $\pm$ 25 %	0.3	400
MT3225-520Y	52 $\pm$ 25 %	0.3	400
MT3225-600Y	60 $\pm$ 25 %	0.3	400
MT3266-600Y	60 $\pm$ 25 %	0.3	400
MT3261-190Y	19 $\pm$ 25 %	0.2	500
MT3261-260Y	26 $\pm$ 25 %	0.2	500
MT3261-310Y	31 $\pm$ 25 %	0.2	500
MT3261-420Y	42 $\pm$ 25 %	0.2	500
MT3261-500Y	50 $\pm$ 25 %	0.2	500
MT3261-700Y	70 $\pm$ 25 %	0.2	500
MT3261-900Y	90 $\pm$ 25 %	0.2	500
MT2029-070Y	7 $\pm$ 25 %	0.2	600
MT2029-100Y	10 $\pm$ 25 %	0.2	600
MT2029-110Y	11 $\pm$ 25 %	0.2	600
MT2029-170Y	17 $\pm$ 25 %	0.1	600
MT2029-260Y	26 $\pm$ 25 %	0.1	600
MT2029-300Y	30 $\pm$ 25 %	0.1	600
MT2029-400Y	40 $\pm$ 25 %	0.1	600
MT1608-050Y	5 $\pm$ 25 %	0.2	600
MT1608-090Y	9 $\pm$ 25 %	0.2	500
MT1608-300Y	30 $\pm$ 25 %	0.3	400

### General Specifications

Operating Temperature .....-55 °C to +125 °C  
 Storage Temperature...-55 °C to +125 °C  
 Storage Condition .....+40 °C max. at 70 % RH  
 Reflow Soldering .....230 °C, 50 seconds max.  
 Resistance to Soldering Heat .....260 °C, 5 seconds  
 Rated Current .....Based on max. temperature rise of +40 °C  
 Terminal Strength (Force "F" applied for 30 seconds)  
 4532 Series .....1.5 F (Kg)  
 4516 Series .....1.0 F (Kg)  
 3225 Series .....1.0 F (Kg)  
 3266 Series .....1.0 F (Kg)  
 3261 Series .....1.0 F (Kg)  
 2029 Series .....0.6 F (Kg)  
 1608 Series .....0.5 F (Kg)

### Materials

Core Material .....Ferrite  
 Internal Conductor .....Ag or Ag/Pd  
 Terminal .....Ag/Ni/Sn

### Electrical Specifications (continued)

MT 4532- 250Y

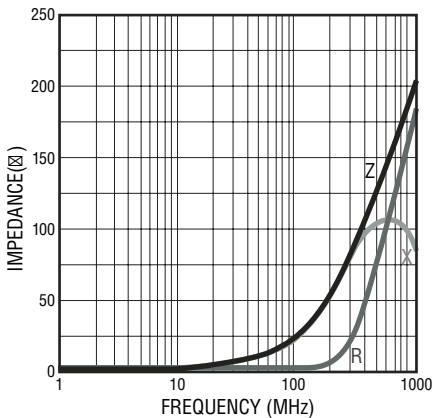

MT 4532- 700Y

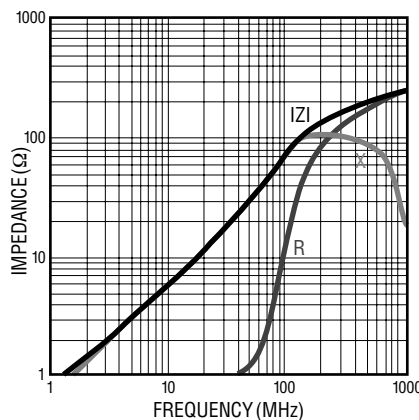

MT 4532- 121Y

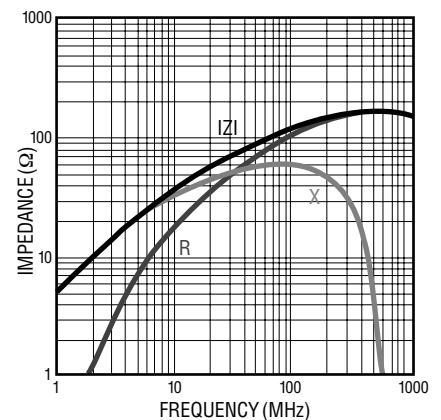

\*RoHS Directive 2002/95/EC Jan 27 2003 including Annex  
 Specifications are subject to change without notice.  
 Customers should verify actual device performance in their specific applications.

# MT Series Low Impedance Chip Ferrite Beads

**BOURNS®**

## Electrical Specifications (continued)

**MT 4532- 131Y**

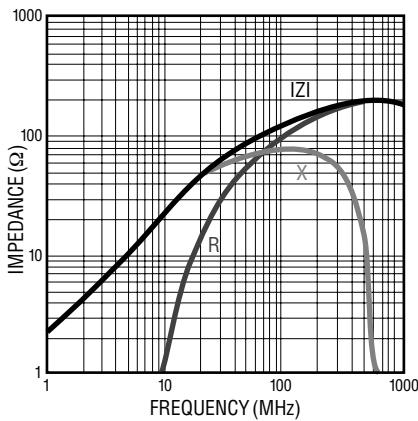

**MT 4516- 800Y**

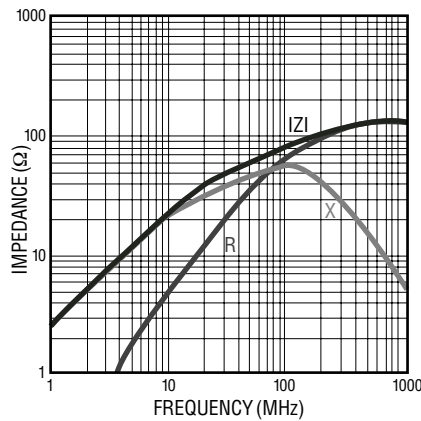

**MT 4516- 101Y**

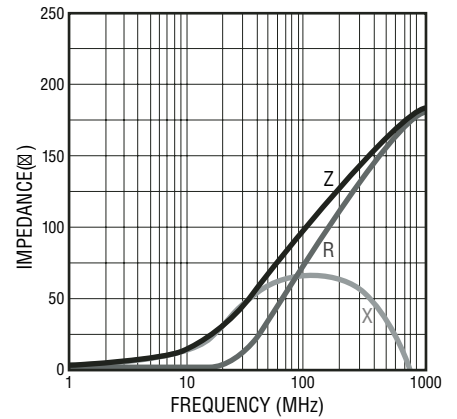

**MT 4516- 151Y**

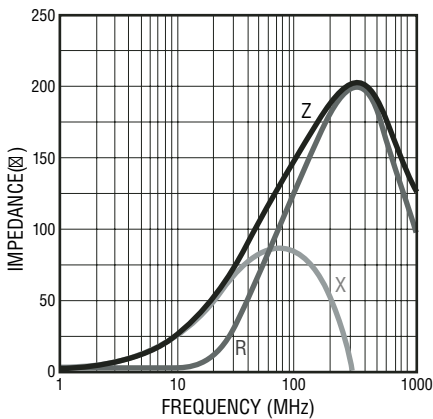

**MT 3225- 310Y**

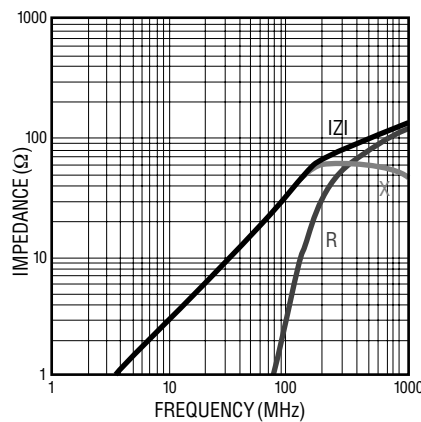

**MT 3225- 520Y**

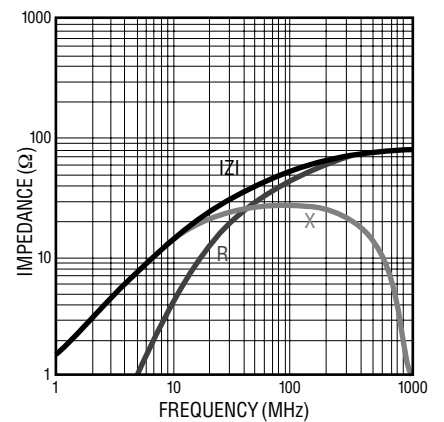

**MT 3225- 600Y**

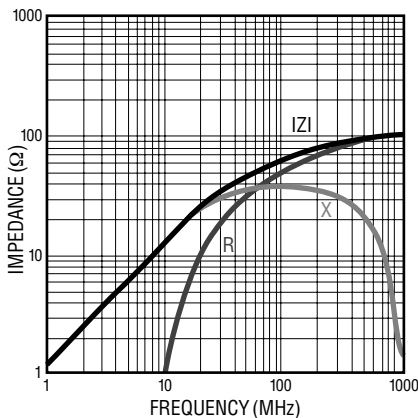

**MT 3266- 600Y**

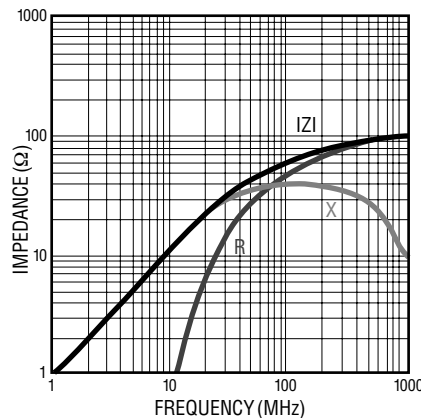

**MT 3261- 190Y**

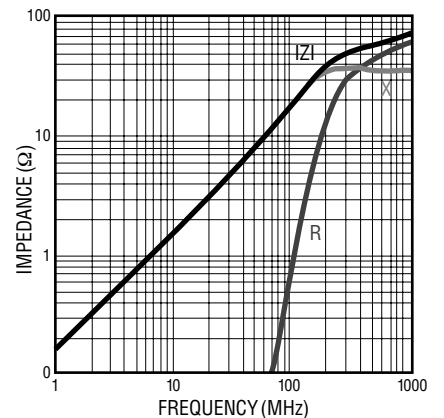

Specifications are subject to change without notice.  
Customers should verify actual device performance in their specific applications.

# MT Series Low Impedance Chip Ferrite Beads

**BOURNS®**

## Electrical Specifications (continued)

**MT 3261- 260Y**

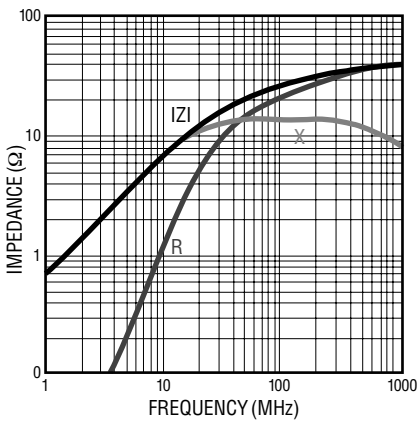

**MT 3261- 310Y**

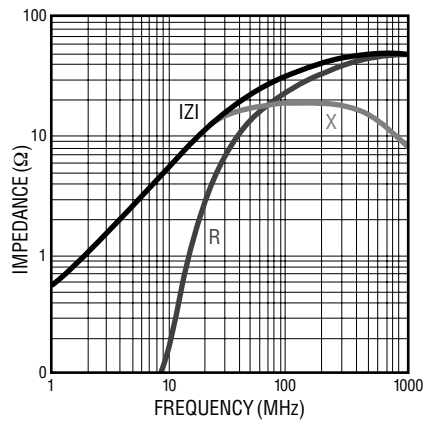

**MT 3261- 420Y**

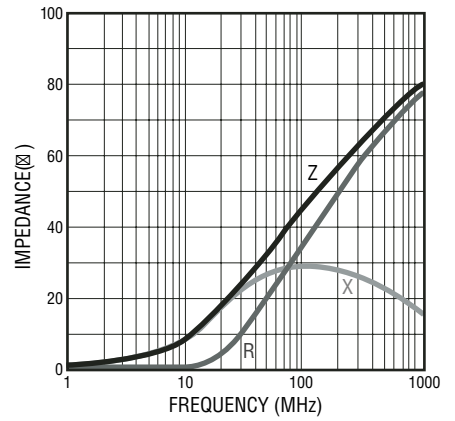

**MT 3261- 500Y**

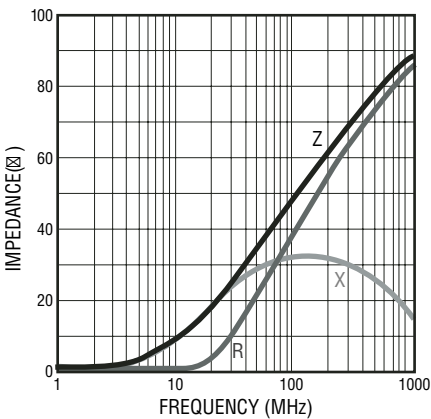

**MT 3261- 700Y**

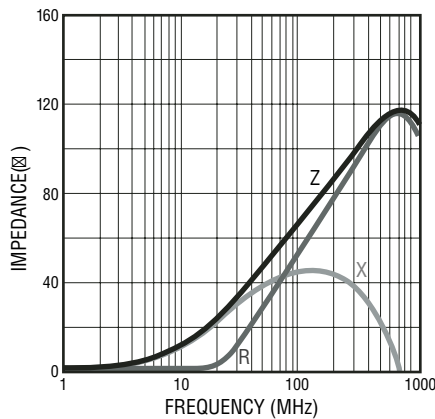

**MT 3261- 900Y**

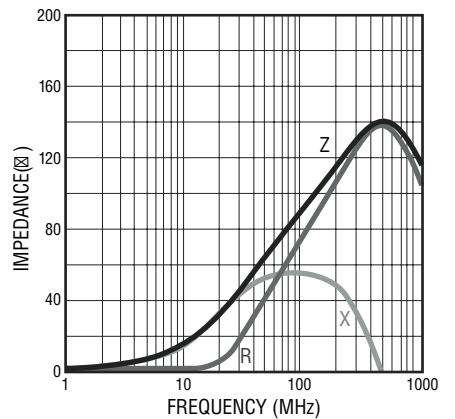

**MT 2029- 070Y**

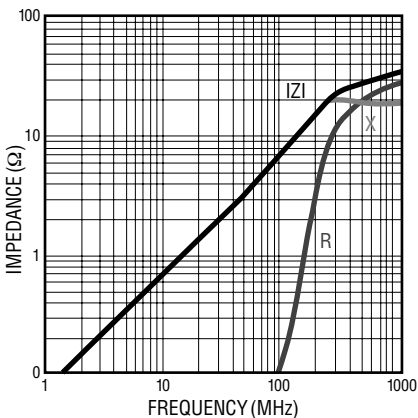

**MT 2029- 100Y**

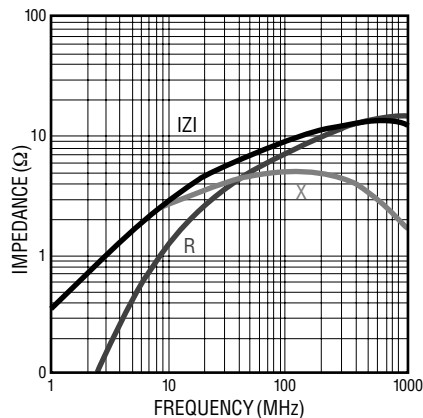

**MT 2029- 110Y**

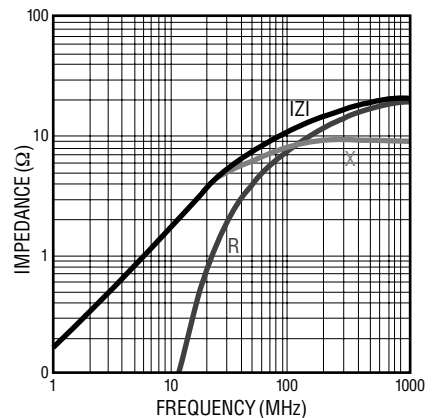

Specifications are subject to change without notice. Customers should verify actual device performance in their specific applications.

# MT Series Low Impedance Chip Ferrite Beads

**BOURNS®**

## Electrical Specifications (continued)

**MT 2029- 170Y**

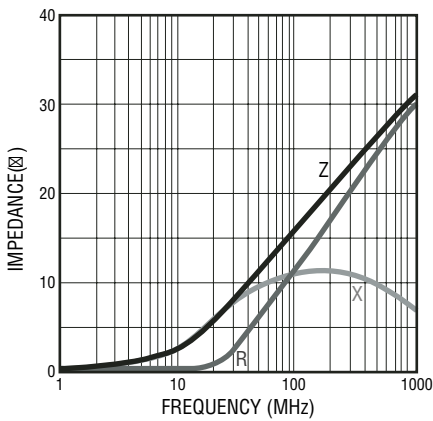

**MT 2029- 260Y**

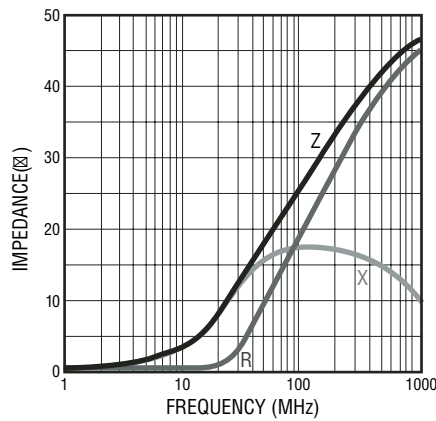

**MT 2029- 300Y**

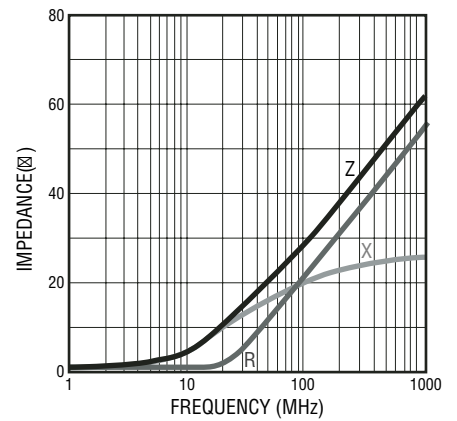

**MT 2029- 400Y**

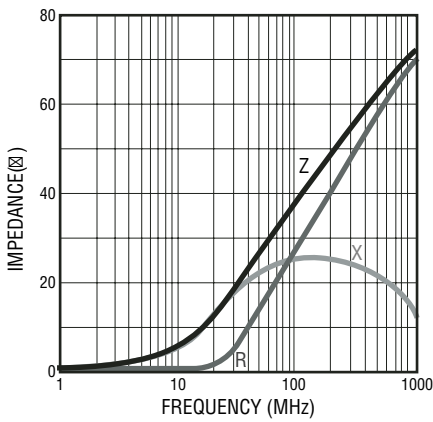

**MT 1608- 050Y**

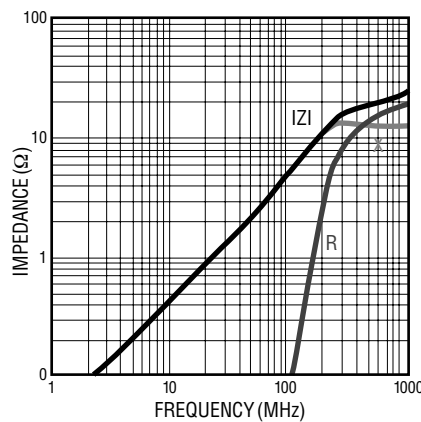

**MT 1608- 090Y**

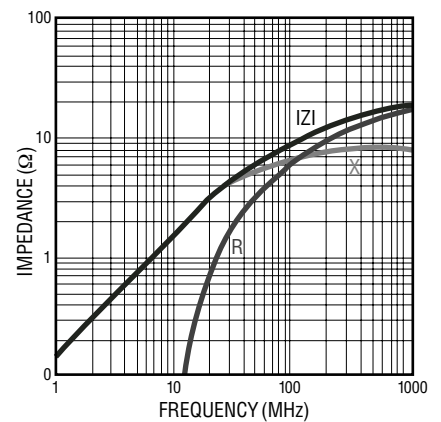

**MT 1608- 300Y**

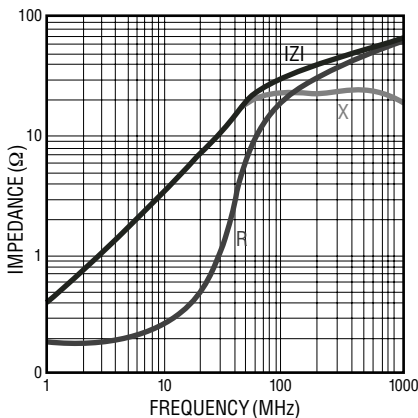

## Equivalent Circuit

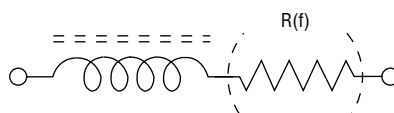

## Recommended Soldering

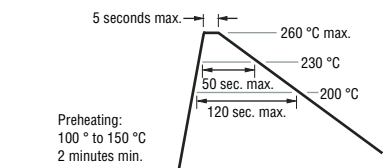

Specifications are subject to change without notice.  
Customers should verify actual device performance in their specific applications.

# MT Series Low Impedance Chip Ferrite Beads

**BOURNS®**

## Product Dimensions

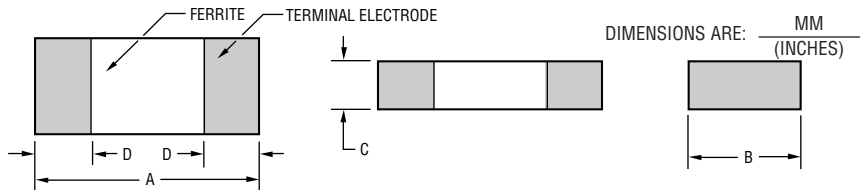

## Recommended Land Pattern

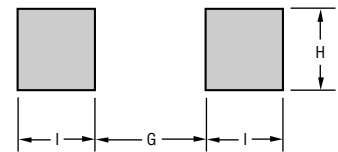

Series	A	B	C	D	G	H	I
4532	$\frac{4.5 \pm 0.2}{(.177 \pm .008)}$	$\frac{3.2 \pm 0.2}{(.126 \pm .008)}$	$\frac{1.5 \pm 0.2}{(.059 \pm .008)}$	$\frac{0.5 \pm 0.2}{(.020 \pm .008)}$	$\frac{3.0}{(.118)}$	$\frac{3.0}{(.118)}$	$\frac{1.5}{(.059)}$
4516	$\frac{4.5 \pm 0.2}{(.177 \pm .008)}$	$\frac{1.6 \pm 0.2}{(.063 \pm .008)}$	$\frac{1.6 \pm 0.2}{(.063 \pm .008)}$	$\frac{0.5 \pm 0.2}{(.020 \pm .008)}$	$\frac{3.0}{(.118)}$	$\frac{1.4}{(.055)}$	$\frac{1.5}{(.059)}$
3266	$\frac{3.2 \pm 0.2}{(.126 \pm .008)}$	$\frac{1.6 \pm 0.2}{(.063 \pm .008)}$	$\frac{1.6 \pm 0.2}{(.063 \pm .008)}$	$\frac{0.5 \pm 0.2}{(.020 \pm .008)}$	$\frac{2.2}{(.118)}$	$\frac{1.4}{(.053)}$	$\frac{1.1}{(.043)}$
3261	$\frac{3.2 \pm 0.2}{(.126 \pm .008)}$	$\frac{1.6 \pm 0.2}{(.063 \pm .008)}$	$\frac{1.1 \pm 0.2}{(.043 \pm .008)}$	$\frac{0.5 \pm 0.2}{(.020 \pm .008)}$	$\frac{2.0}{(.079)}$	$\frac{1.4}{(.053)}$	$\frac{1.1}{(.043)}$
3225	$\frac{3.2 \pm 0.2}{(.126 \pm .008)}$	$\frac{2.5 \pm 0.2}{(.098 \pm .008)}$	$\frac{1.3 \pm 0.2}{(.051 \pm .008)}$	$\frac{0.5 \pm 0.2}{(.020 \pm .008)}$	$\frac{2.2}{(.118)}$	$\frac{2.3}{(.091)}$	$\frac{1.1}{(.043)}$
2029	$\frac{2.0 \pm 0.2}{(.079 \pm .008)}$	$\frac{1.2 \pm 0.2}{(.047 \pm .008)}$	$\frac{0.9 \pm 0.2}{(.035 \pm .008)}$	$\frac{0.5 \pm 0.2}{(.020 \pm .008)}$	$\frac{1.0}{(.040)}$	$\frac{1.0}{(.040)}$	$\frac{1.0}{(.040)}$
1608	$\frac{1.6 \pm 0.2}{(.063 \pm .008)}$	$\frac{0.8 \pm 0.2}{(.031 \pm .008)}$	$\frac{0.8 \pm 0.2}{(.031 \pm .008)}$	$\frac{0.5 \pm 0.2}{(.020 \pm .008)}$	$\frac{0.7}{(.028)}$	$\frac{0.7}{(.128)}$	$\frac{0.7}{(.128)}$

## Reel Dimensions

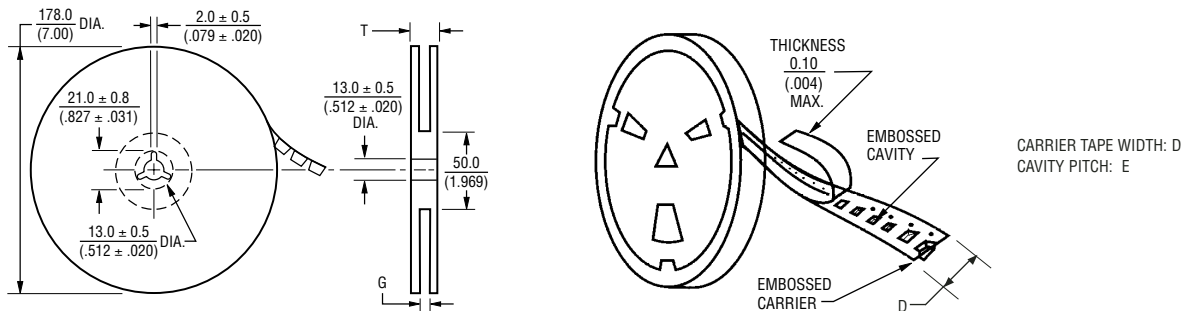

Series	Pcs. per Reel	Gross Weight (g)	D	E	G	T
4532	1,000	170	$\frac{12.0}{(.472)}$	$\frac{8.0}{(.315)}$	$\frac{14.0 + 0}{(.551 + 0)}$	$\frac{16.5}{(.650)}$
4516	2,000	180	$\frac{12.0}{(.472)}$	$\frac{8.0}{(.315)}$	$\frac{14.0 + 0}{(.551 + 0)}$	$\frac{16.5}{(.650)}$
3266	2,000	140	$\frac{8.0}{(.315)}$	$\frac{4.0}{(.157)}$	$\frac{10.0 + 0}{(.394 + 0)}$	$\frac{12.5}{(.492)}$
3261	3,000	150	$\frac{8.0}{(.315)}$	$\frac{4.0}{(.157)}$	$\frac{10.0 + 0}{(.394 + 0)}$	$\frac{12.5}{(.492)}$
3225	2,500	160	$\frac{8.0}{(.315)}$	$\frac{4.0}{(.157)}$	$\frac{10.0 + 0}{(.394 + 0)}$	$\frac{12.5}{(.492)}$
2029	4,000	120	$\frac{8.0}{(.315)}$	$\frac{4.0}{(.157)}$	$\frac{10.0 + 0}{(.394 + 0)}$	$\frac{12.5}{(.492)}$
1608	4,000	90	$\frac{8.0}{(.315)}$	$\frac{4.0}{(.157)}$	$\frac{10.0 + 0}{(.394 + 0)}$	$\frac{12.5}{(.492)}$



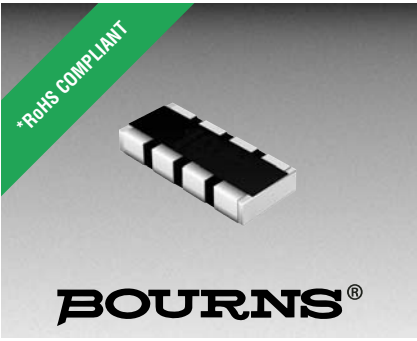

### Features

- Four beads in one package
- High speed and high impedance
- Nickel barrier

### Applications

- Waveform correction in:
  - Personal computers
  - Electrical equipment
  - Communication equipment
- Prevents noise intrusion in video, LCD
- Parallel signal line

## MA Series Chip Ferrite Bead Arrays

### Electrical Specifications

Model Number	Impedance (Ω) at 100MHz	RDC (Ω) Max.	IDC (mA) Max.
MA3216-600M4	60	0.12	200
MA3216-800M4	80	0.15	150
MA3216-121M4	120	0.20	100
MA3216-201M4	200	0.30	100
MA3216-301M4	300	0.45	100
MA3216-471M4	470	0.45	100
MA3216-601M4	600	0.50	100
MA3216-102M4	1000	0.80	100
MA3216-600T4	60	0.12	200
MA3216-121T4	120	0.20	200
MA3216-201T4	200	0.30	150
MA3216-301T4	300	0.45	150
MA3216-601T4	600	0.50	100
MA3216-102T4	1000	0.80	50
MA3216-500S4	50	0.20	200
MA3216-800S4	80	0.25	200
MA3216-121S4	120	0.25	200
MA3216-201S4	200	0.30	200
MA3216-301S4	300	0.40	200

### General Specifications

Operating Temperature .....-55 °C to +125 °C  
 Storage Temperature...-55 °C to +125 °C  
 Storage Condition .....+40 °C max. at 70 % RH  
 Impedance Tolerance.....±25 %  
 Reflow Soldering .....230 °C, 10 seconds max.  
 Resistance to Soldering Heat .....260 °C, 10 seconds  
 Model Designator  
 M4 .....High Impedance  
 T4 .....Low Speed  
 S4 .....High Speed  
 Rated Current.....Based on max. temperature rise of +40 °C  
 Terminal Strength (Force "F" applied for 30 seconds)  
 3216 Series.....1.2 F (Kg)

### Materials

Core Material .....Ferrite  
 Internal Conductor.....Ag  
 Terminal .....Ag/Ni/Sn

### Electrical Specifications (continued)

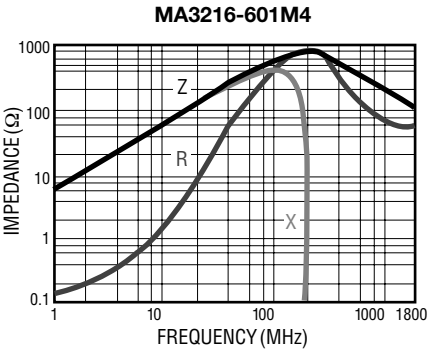
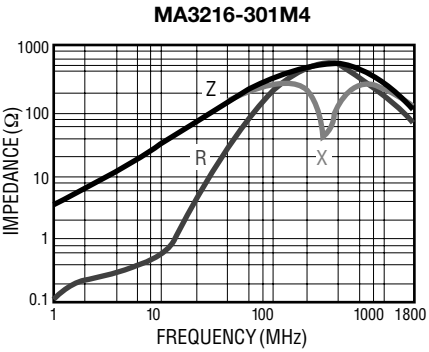
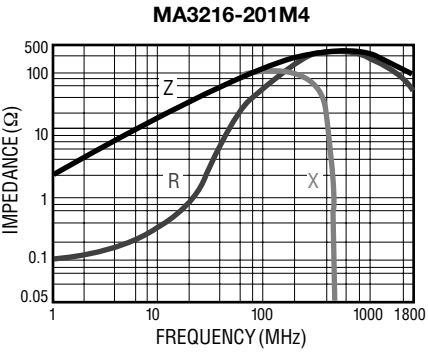
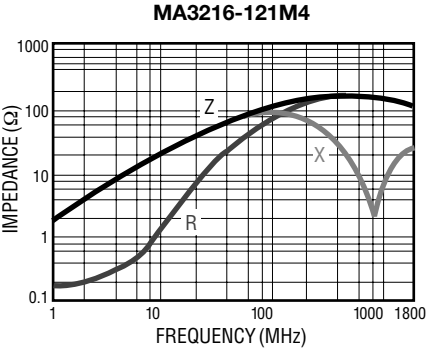
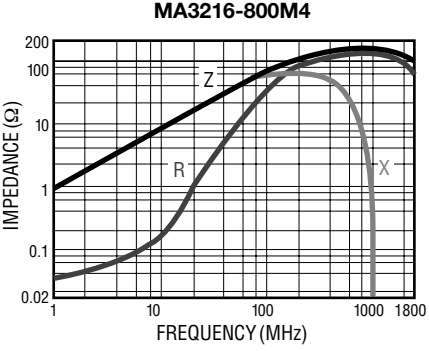
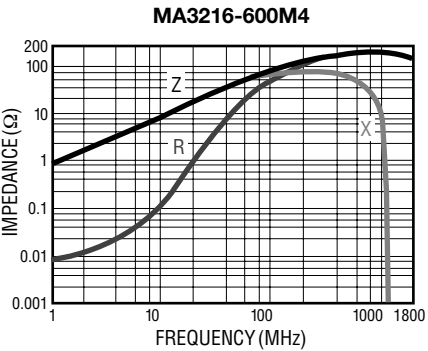

\*RoHS Directive 2002/95/EC Jan 27 2003 including Annex Specifications are subject to change without notice. Customers should verify actual device performance in their specific applications.

# MA Series Chip Ferrite Bead Arrays

## Electrical Specifications (Continued)

**MA3216-102M4**

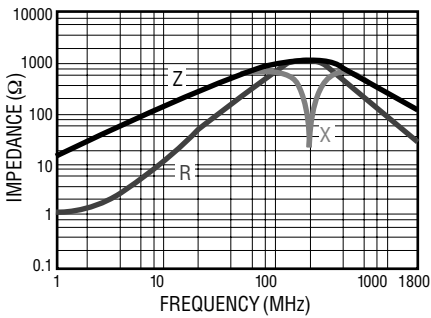

**MA3216-121T4**

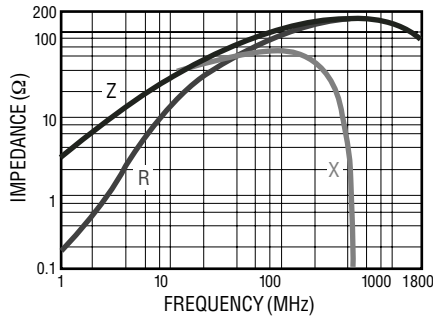

**MA3216-201T4**

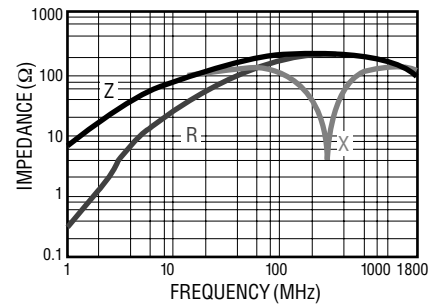

**MA3216-301T4**

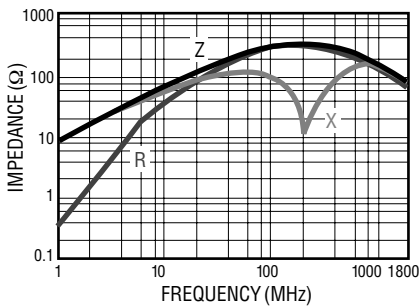

**MA3216-601T4**

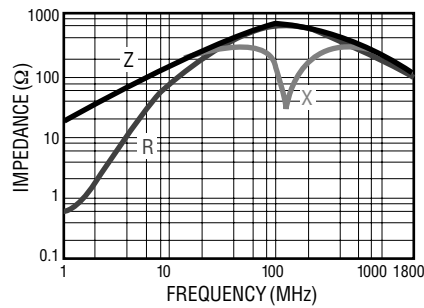

**MA3216-500S4**

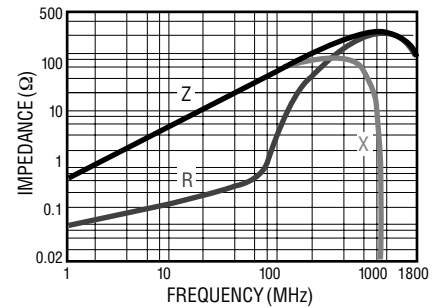

**MA3216-800S4**

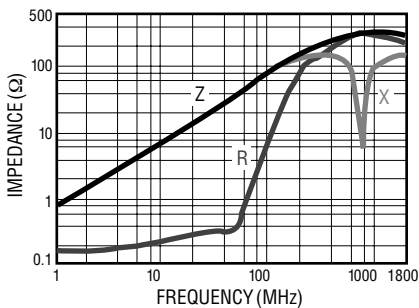

**MA3216-121S4**

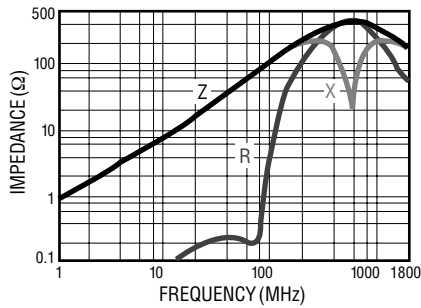

**MA3216-201S4**

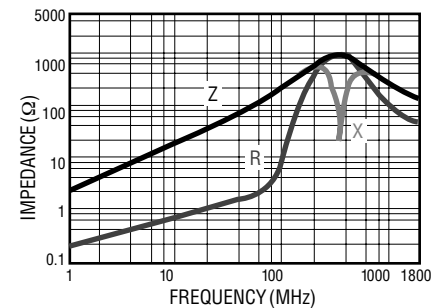

**MA3216-301S4**

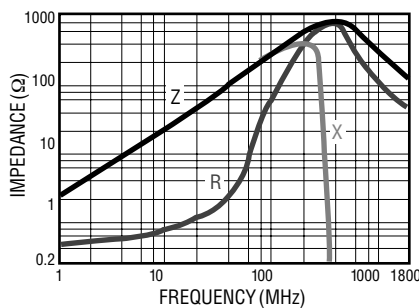

Specifications are subject to change without notice. Customers should verify actual device performance in their specific applications.

# MA Series Chip Ferrite Bead Arrays

## Product Dimensions

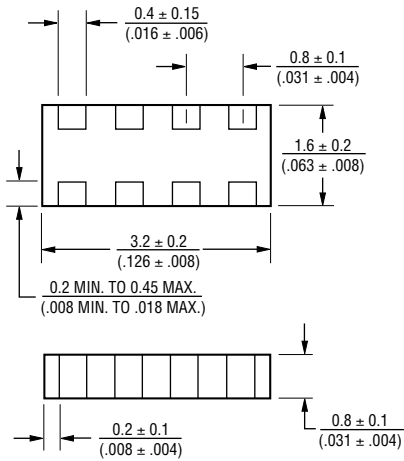

## Recommended Land Pattern

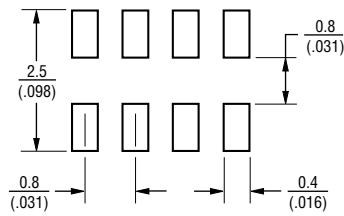

DIMENSIONS ARE:  $\frac{\text{MM}}{\text{(INCHES)}}$

## Recommended Soldering

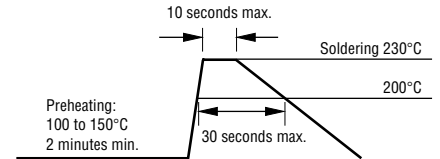

## Reel Dimensions

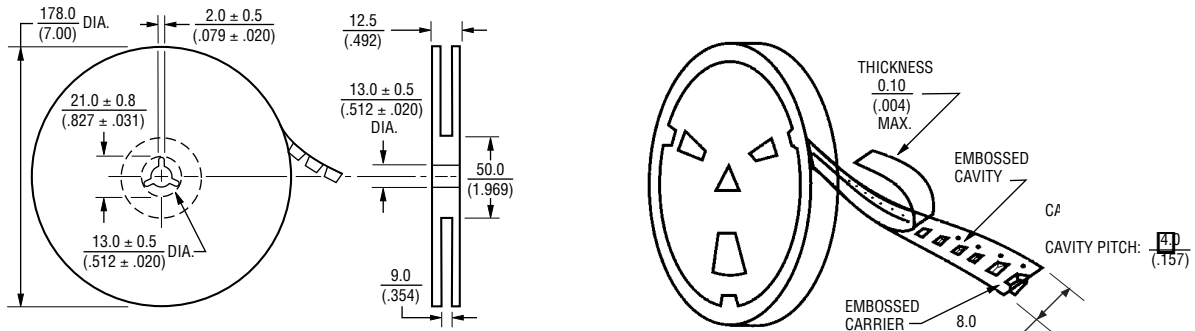

3000 pcs. per reel.  
Gross weight: 140g.



---

#### **IV. Through-Hole Inductors**

Product Capability Matrix .....	182
Product Specifications	
• <i>RLB Series Radial Inductors</i> .....	183
• <i>FSR1013 Radial Shielded Inductors</i> .....	190
• <i>PT121 Radial High Q Inductors</i> .....	191
• <i>LPA Series Axial Power Inductors</i> .....	192
• <i>LPV Series Radial Power Inductors</i> .....	193

# Through-Hole Inductors Product Capability Matrix

## Product Selection Guide

Model	Non-Shielded	Shielded	Axial	Radial	Power Ind.	High Q	Product Size (mm)		Inductance Range $\mu$ H
							Length	Height	
RLB0608	●			●		●	5.0	6.5	1.0 to 1000
RLB0812	●			●		●	6.7	10.0	47 to 47000
RLB1014	●			●			8.7	12.0	100 to 82000
RLB0712	●			●			6.7	10.0	10 to 560
RLB0912	●			●			8.7	10.0	1.5 to 1000
RLB0914	●			●			8.7	12.0	3.3 to 1000
RLB1314	●			●			11.7	12.0	3.3 to 15000
FSR1013		●		●			10.5	13.0	1000 to 47000
PT121	●			●		●	8.0	11.2	100 to 33000
LPA0618	●		●		●		18.0	6.0	10 to 1000
LPA1020	●		●		●		20.0	10.0	10 to 1000
LPA1226	●		●		●		26.0	12.0	10 to 1000
LPV1620	●			●	●		16.0	20.0	10 to 1000
LPV1823	●			●	●		18.0	23.0	10 to 1000
LPV2023	●			●	●		20.0	23.0	10 to 2000

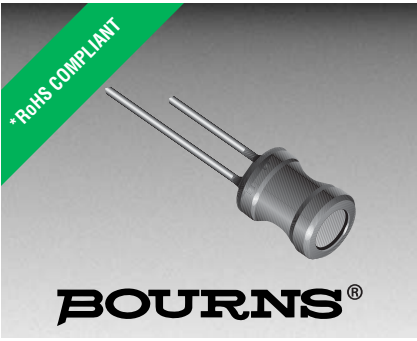

## Features

- Four types available
- High rated current for high current circuits
- Available in E12 series
- RoHS compliant\*

## Applications

- Power supplies
- DC/DC converters
- General use

# RLB Series Radial Inductors

### General Specifications

Temperature Rise .....20 °C max. at rated current  
 Operating Temperature .....-40 °C to +105 °C  
 Storage Temperature .....-40 °C to +105 °C

### Materials

Core Material .....Ferrite DR core  
 Wire .....Enameled copper wire  
 Terminal .....Cu/Sn  
 Tube .....Shrinkable tube 125 °C, 600 V

### Product Dimensions

RLB0608, RLB0812, RLB1014,  
RLB0712, RLB0914 Series

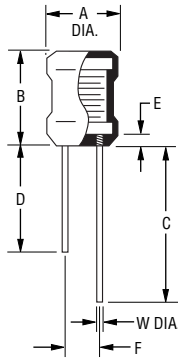

RLB0912 Series

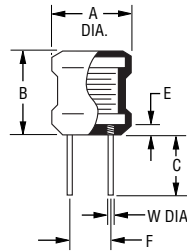

RLB1314-680K  
thru RLB1314-153K

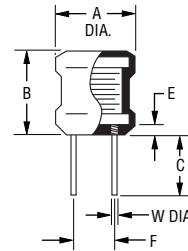

RLB1314-3R3M  
thru RLB1314-470K

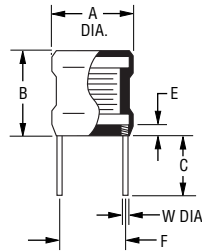

Series	A	B	C	D	E	F	W (DIA.)	Inductance Range
RLB0608	$\frac{5.0 \pm 0.5}{(.197 \pm .020)}$	$\frac{6.5 +1.0/-0.5}{(.256 +.039/- .020)}$	$\frac{28.0 \pm 5.0}{(1.102 \pm .197)}$	$\frac{20.0 \pm 5.0}{(.787 \pm .197)}$	$\frac{2.5 + 0}{(.098 + 0)}$	$\frac{2.0 \pm 0.5}{(.079 \pm .020)}$	$\frac{0.50}{(.020)}$	1.0 $\mu$ H — 2200 $\mu$ H
RLB0812	$\frac{6.7 \pm 0.5}{(.264 \pm .020)}$	$\frac{10.0 \pm 1.0}{(.394 \pm .039)}$	$\frac{25.0 \pm 5.0}{(.984 \pm .197)}$	$\frac{18.0 \pm 5.0}{(.709 \pm .197)}$	$\frac{2.5 + 0}{(.098 + 0)}$	$\frac{3.0 \pm 0.5}{(.118 \pm .020)}$	$\frac{0.65}{(.026)}$	47 $\mu$ H — 47 mH
RLB1014	$\frac{8.7 \pm 0.5}{(.343 \pm .020)}$	$\frac{12.0 \pm 1.0}{(.472 \pm .039)}$	$\frac{25.0 \pm 5.0}{(.984 \pm .197)}$	$\frac{18.0 \pm 5.0}{(.709 \pm .197)}$	$\frac{2.5 + 0}{(.098 + 0)}$	$\frac{5.0 \pm 0.8}{(.197 \pm .031)}$	$\frac{0.65}{(.026)}$	100 $\mu$ H — 82 mH
RLB0712	$\frac{6.7 \pm 0.5}{(.264 \pm .020)}$	$\frac{10.0 \pm 1.0}{(.394 \pm .039)}$	$\frac{25.0 \pm 5.0}{(.984 \pm .197)}$	$\frac{18.0 \pm 5.0}{(.709 \pm .197)}$	$\frac{2.5 + 0}{(.098 + 0)}$	$\frac{3.0 \pm 0.5}{(.118 \pm .020)}$	$\frac{0.65}{(.026)}$	10 $\mu$ H — 560 $\mu$ H
RLB0912	$\frac{8.7 \pm 0.5}{(.343 \pm .020)}$	$\frac{10.0 \pm 1.0}{(.394 \pm .039)}$	$\frac{5.0 \pm 1.0}{(.197 \pm .039)}$	—	$\frac{2.5 + 0}{(.098 + 0)}$	$\frac{5.0 \pm 0.8}{(.197 \pm .031)}$	$\frac{0.65}{(.026)}$	1.5 $\mu$ H — 1000 $\mu$ H
RLB0914	$\frac{8.7 \pm 0.5}{(.343 \pm .020)}$	$\frac{12.0 \pm 1.0}{(.472 \pm .039)}$	$\frac{25.0 \pm 5.0}{(.984 \pm .197)}$	$\frac{18.0 \pm 5.0}{(.709 \pm .197)}$	$\frac{2.5 + 0}{(.098 + 0)}$	$\frac{5.0 \pm 0.8}{(.197 \pm .031)}$	$\frac{0.65}{(.026)}$	3.3 $\mu$ H — 1000 $\mu$ H
RLB1314	$\frac{11.7 \pm 0.8}{(.461 \pm .031)}$	$\frac{12.0 \pm 1.0}{(.472 \pm .039)}$	$\frac{15.0 \pm 5.0}{(.591 \pm .197)}$	—	$\frac{2.5 + 0}{(.098 + 0)}$	$\frac{9.0 \pm 1.0}{(.354 \pm .039)}$	Per Specs.	3.3 $\mu$ H — 47 $\mu$ H
	$\frac{11.7 \pm 0.8}{(.461 \pm .031)}$	$\frac{12.0 \pm 1.0}{(.472 \pm .039)}$	$\frac{15.0 \pm 5.0}{(.591 \pm .197)}$	—	$\frac{2.5 + 0}{(.098 + 0)}$	$\frac{7.0 \pm 0.8}{(.276 \pm .031)}$	$\frac{0.80}{(.031)}$	68 $\mu$ H — 15 mH

DIMENSIONS ARE:  $\frac{\text{MM}}{\text{(INCHES)}}$

\*RoHS Directive 2002/95/EC Jan 27 2003 including Annex  
 Specifications are subject to change without notice.  
 Customers should verify actual device performance in their specific applications.

# RLB Series Radial Inductors

## Electrical Schematic

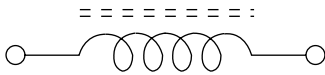

## Typical Part Marking



Inductance Code:  
 - First two digits are significant  
 - Third digit represents the number of zeroes to follow  
 • = Start

## RLB0608 Series Electrical Characteristics

BOURNS Part No.	Inductance (μH)	Q ref.	Test freq. (MHz) L, Q	SRF (MHz) min.	RDC (Ω) max.	IDC (mA) max.
RLB0608-1R0ML	1.0 ± 20 %	60	7.96	105.0	0.10	1030
RLB0608-1R2ML	1.2 ± 20 %	60	7.96	90.0	0.15	980
RLB0608-1R5ML	1.5 ± 20 %	60	7.96	75.0	0.20	920
RLB0608-1R8ML	1.8 ± 20 %	60	7.96	70.0	0.22	880
RLB0608-2R2ML	2.2 ± 20 %	60	7.96	65.0	0.24	830
RLB0608-2R7ML	2.7 ± 20 %	60	7.96	60.0	0.27	790
RLB0608-3R3ML	3.3 ± 20 %	60	7.96	50.0	0.30	750
RLB0608-3R9ML	3.9 ± 20 %	60	7.96	45.0	0.30	720
RLB0608-4R7ML	4.7 ± 20 %	60	7.96	40.0	0.35	670
RLB0608-5R6KL	5.6 ± 10 %	60	7.96	35.0	0.35	640
RLB0608-6R8KL	6.8 ± 10 %	60	7.96	30.0	0.40	620
RLB0608-8R2KL	8.2 ± 10 %	60	7.96	25.0	0.40	590
RLB0608-100KL	10.0 ± 10 %	60	2.52	20.0	0.45	550
RLB0608-120KL	12.0 ± 10 %	60	2.52	15.0	0.50	530
RLB0608-150KL	15.0 ± 10 %	60	2.52	13.0	0.55	500
RLB0608-180KL	18.0 ± 10 %	60	2.52	11.0	0.60	480
RLB0608-220KL	22.0 ± 10 %	60	2.52	10.0	0.65	460
RLB0608-270KL	27.0 ± 10 %	50	2.52	9.0	0.75	430
RLB0608-330KL	33.0 ± 10 %	50	2.52	8.0	0.85	410
RLB0608-390KL	39.0 ± 10 %	50	2.52	7.5	0.90	390
RLB0608-470KL	47.0 ± 10 %	50	2.52	7.0	1.00	370
RLB0608-560KL	56.0 ± 10 %	50	2.52	6.5	1.20	350
RLB0608-680KL	68.0 ± 10 %	50	2.52	6.0	1.30	340
RLB0608-820KL	82.0 ± 10 %	50	2.52	5.5	1.50	320
RLB0608-101KL	100.0 ± 10 %	50	0.796	5.0	1.70	305
RLB0608-121KL	120.0 ± 10 %	50	0.796	4.8	1.90	290
RLB0608-151KL	150.0 ± 10 %	50	0.796	4.4	2.10	275
RLB0608-181KL	180.0 ± 10 %	50	0.796	4.2	2.30	235
RLB0608-221KL	220.0 ± 10 %	45	0.796	3.8	2.50	200
RLB0608-271KL	270.0 ± 10 %	45	0.796	3.6	2.75	180
RLB0608-331KL	330.0 ± 10 %	45	0.796	3.3	4.68	165
RLB0608-391KL	390.0 ± 10 %	45	0.796	3.0	6.00	150
RLB0608-471KL	470.0 ± 10 %	55	0.796	2.8	6.50	140
RLB0608-561KL	560.0 ± 10 %	55	0.796	2.4	8.50	135
RLB0608-681KL	680.0 ± 10 %	55	0.796	2.2	9.00	125
RLB0608-821KL	820.0 ± 10 %	55	0.796	2.0	9.60	120
RLB0608-102KL	1000.0 ± 10 %	55	0.252	1.8	11.50	100
RLB0608-152KL	1500.0 ± 10 %	50	0.252	1.4	15.00	100
RLB0608-222KL	2200.0 ± 10 %	50	0.252	1.0	20.00	85

Packaging: 800 pieces per bag

Specifications are subject to change without notice.  
 Customers should verify actual device performance in their specific applications.



# RLB Series Radial Inductors

## RLB0812 Series Electrical Characteristics

BOURNS Part No.	Inductance ( $\mu$ H)	Q ref.	Test freq. (MHz) L, Q	SRF (MHz) min.	RDC ( $\Omega$ ) max.	IDC (mA) max.
RLB0812-470KL	47 $\pm$ 10 %	30	2.52	6.00	0.40	450
RLB0812-560KL	56 $\pm$ 10 %	30	2.52	5.50	0.45	400
RLB0812-680KL	68 $\pm$ 10 %	30	2.52	5.00	0.50	360
RLB0812-820KL	82 $\pm$ 10 %	30	2.52	4.50	0.50	340
RLB0812-101KL	100 $\pm$ 10 %	45	0.796	4.20	0.60	320
RLB0812-121KL	120 $\pm$ 10 %	45	0.796	3.60	0.70	300
RLB0812-151KL	150 $\pm$ 10 %	45	0.796	3.40	0.90	280
RLB0812-181KL	180 $\pm$ 10 %	45	0.796	3.20	1.00	260
RLB0812-221KL	220 $\pm$ 10 %	45	0.796	3.00	1.20	240
RLB0812-271KL	270 $\pm$ 10 %	45	0.796	2.80	1.40	220
RLB0812-331KL	330 $\pm$ 10 %	45	0.796	2.50	1.60	200
RLB0812-391KL	390 $\pm$ 10 %	45	0.796	2.30	1.80	180
RLB0812-471KL	470 $\pm$ 10 %	45	0.796	2.20	2.00	160
RLB0812-561KL	560 $\pm$ 10 %	45	0.796	2.00	2.50	150
RLB0812-681KL	680 $\pm$ 10 %	45	0.796	1.70	2.90	140
RLB0812-821KL	820 $\pm$ 10 %	45	0.796	1.50	3.10	130
RLB0812-102KL	1000 $\pm$ 10 %	45	0.252	1.40	3.90	120
RLB0812-122KL	1200 $\pm$ 10 %	60	0.252	1.10	4.40	110
RLB0812-152KL	1500 $\pm$ 10 %	60	0.252	0.90	6.00	100
RLB0812-182KL	1800 $\pm$ 10 %	60	0.252	0.80	7.00	90
RLB0812-222KL	2200 $\pm$ 10 %	60	0.252	0.75	8.00	80
RLB0812-272KL	2700 $\pm$ 10 %	60	0.252	0.70	9.00	70
RLB0812-332KL	3300 $\pm$ 10 %	60	0.252	0.60	12.00	60
RLB0812-392KL	3900 $\pm$ 10 %	60	0.252	0.55	14.00	55
RLB0812-472KL	4700 $\pm$ 10 %	60	0.252	0.50	16.00	50
RLB0812-562KL	5600 $\pm$ 10 %	60	0.252	0.48	18.00	45
RLB0812-682KL	6800 $\pm$ 10 %	60	0.252	0.44	24.00	40
RLB0812-822KL	8200 $\pm$ 10 %	60	0.252	0.40	30.00	36
RLB0812-103KL	10000 $\pm$ 10 %	60	0.0796	0.36	39.00	34
RLB0812-123KL	12000 $\pm$ 10 %	60	0.0796	0.32	46.00	32
RLB0812-153KL	15000 $\pm$ 10 %	60	0.0796	0.30	54.00	30
RLB0812-183KL	18000 $\pm$ 10 %	60	0.0796	0.28	76.00	27
RLB0812-223KL	22000 $\pm$ 10 %	60	0.0796	0.24	92.00	25
RLB0812-273KL	27000 $\pm$ 10 %	60	0.0796	0.20	102.00	22
RLB0812-333KL	33000 $\pm$ 10 %	60	0.0796	0.16	140.00	20
RLB0812-393KL	39000 $\pm$ 10 %	60	0.0796	0.13	150.00	18
RLB0812-473KL	47000 $\pm$ 10 %	60	0.0796	0.10	162.00	16

Packaging: 400 pieces per bag

# RLB Series Radial Inductors

## RLB1014 Series Electrical Characteristics

BOURNS Part No.	Inductance ( $\mu$ H)	Q ref.	Test freq. (KHz) L, Q	SRF (MHz) min.	RDC ( $\Omega$ ) max.	IDC (mA) max.
RLB1014-101KL	100 $\pm$ 10 %	45	796.0	3.20	0.85	350
RLB1014-121KL	120 $\pm$ 10 %	45	796.0	3.00	0.95	330
RLB1014-151KL	150 $\pm$ 10 %	45	796.0	2.80	1.05	310
RLB1014-181KL	180 $\pm$ 10 %	45	796.0	2.50	1.15	300
RLB1014-221KL	220 $\pm$ 10 %	40	796.0	2.10	1.30	280
RLB1014-271KL	270 $\pm$ 10 %	40	796.0	2.00	1.50	260
RLB1014-331KL	330 $\pm$ 10 %	40	796.0	1.95	1.70	240
RLB1014-391KL	390 $\pm$ 10 %	40	796.0	1.85	1.85	230
RLB1014-471KL	470 $\pm$ 10 %	35	796.0	1.55	2.30	210
RLB1014-561KL	560 $\pm$ 10 %	35	796.0	1.30	2.55	200
RLB1014-681KL	680 $\pm$ 10 %	35	796.0	1.15	2.85	190
RLB1014-821KL	820 $\pm$ 10 %	35	796.0	1.00	3.10	180
RLB1014-102KL	1000 $\pm$ 10 %	50	252.0	0.90	4.10	160
RLB1014-122KL	1200 $\pm$ 10 %	50	252.0	0.80	4.70	150
RLB1014-152KL	1500 $\pm$ 10 %	50	252.0	0.70	5.80	130
RLB1014-182KL	1800 $\pm$ 10 %	50	252.0	0.60	7.40	115
RLB1014-222KL	2200 $\pm$ 10 %	50	252.0	0.55	8.40	110
RLB1014-272KL	2700 $\pm$ 10 %	50	252.0	0.50	9.60	95
RLB1014-332KL	3300 $\pm$ 10 %	50	252.0	0.45	10.50	80
RLB1014-392KL	3900 $\pm$ 10 %	50	252.0	0.40	12.00	70
RLB1014-472KL	4700 $\pm$ 10 %	45	252.0	0.38	14.00	65
RLB1014-562KL	5600 $\pm$ 10 %	45	252.0	0.36	16.00	60
RLB1014-682KL	6800 $\pm$ 10 %	40	252.0	0.34	18.00	55
RLB1014-822KL	8200 $\pm$ 10 %	40	252.0	0.32	24.50	50
RLB1014-103KL	10000 $\pm$ 10 %	50	79.6	0.30	32.00	45
RLB1014-123KL	12000 $\pm$ 10 %	50	79.6	0.28	36.00	40
RLB1014-153KL	15000 $\pm$ 10 %	50	79.6	0.26	48.00	35
RLB1014-183KL	18000 $\pm$ 10 %	45	79.6	0.24	52.00	30
RLB1014-223KL	22000 $\pm$ 10 %	45	79.6	0.22	58.00	28
RLB1014-273KL	27000 $\pm$ 10 %	45	79.6	0.20	62.00	26
RLB1014-333KL	33000 $\pm$ 10 %	45	79.6	0.18	90.00	24
RLB1014-393KL	39000 $\pm$ 10 %	40	79.6	0.17	100.00	22
RLB1014-473KL	47000 $\pm$ 10 %	35	79.6	0.16	150.00	20
RLB1014-563KL	56000 $\pm$ 10 %	35	79.6	0.15	200.00	18
RLB1014-683KL	68000 $\pm$ 10 %	35	79.6	0.14	220.00	16
RLB1014-823KL	82000 $\pm$ 10 %	30	79.6	0.12	240.00	14

Packaging: 150 pieces per bag

# RLB Series Radial Inductors

## RLB0712 Series Electrical Characteristics

BOURNS Part No.	Inductance ( $\mu$ H)	Q ref.	Test freq. (Hz)		SRF (MHz) min.	RDC ( $\Omega$ ) max.	IDC (mA) max.
			L	Q			
RLB0712-100KL	10 $\pm$ 10 %	20	1 k	2.520 M	16.0	0.07	1100
RLB0712-120KL	12 $\pm$ 10 %	20	1 k	2.520 M	12.0	0.08	1000
RLB0712-150KL	15 $\pm$ 10 %	20	1 k	2.520 M	10.0	0.09	900
RLB0712-180KL	18 $\pm$ 10 %	20	1 k	2.520 M	10.0	0.10	750
RLB0712-220KL	22 $\pm$ 10 %	20	1 k	2.520 M	9.0	0.12	700
RLB0712-270KL	27 $\pm$ 10 %	20	1 k	2.520 M	8.0	0.13	650
RLB0712-330KL	33 $\pm$ 10 %	20	1 k	2.520 M	7.0	0.15	600
RLB0712-390KL	39 $\pm$ 10 %	20	1 k	2.520 M	6.0	0.16	550
RLB0712-470KL	47 $\pm$ 10 %	20	1 k	2.520 M	6.0	0.18	450
RLB0712-560KL	56 $\pm$ 10 %	20	1 k	2.520 M	5.0	0.21	400
RLB0712-680KL	68 $\pm$ 10 %	20	1 k	2.520 M	5.0	0.24	360
RLB0712-820KL	82 $\pm$ 10 %	20	1 k	2.520 M	5.0	0.35	340
RLB0712-101KL	100 $\pm$ 10 %	20	1 k	0.796 M	4.0	0.40	320
RLB0712-121KL	120 $\pm$ 10 %	20	1 k	0.796 M	4.0	0.45	300
RLB0712-151KL	150 $\pm$ 10 %	20	1 k	0.796 M	3.5	0.50	280
RLB0712-181KL	180 $\pm$ 10 %	20	1 k	0.796 M	3.0	0.75	260
RLB0712-221KL	220 $\pm$ 10 %	20	1 k	0.796 M	3.0	0.90	240
RLB0712-271KL	270 $\pm$ 10 %	20	1 k	0.796 M	2.5	1.00	220
RLB0712-331KL	330 $\pm$ 10 %	20	1 k	0.796 M	2.5	1.10	200
RLB0712-391KL	390 $\pm$ 10 %	20	1 k	0.796 M	2.0	1.20	180
RLB0712-471KL	470 $\pm$ 10 %	20	1 k	0.796 M	2.0	1.50	160
RLB0712-561KL	560 $\pm$ 10 %	20	1 k	0.796 M	2.0	1.80	150

Packaging: 400 pieces per bag

## RLB0912 Series Electrical Characteristics

BOURNS Part No.	Inductance ( $\mu$ H)	Q ref.	Test freq. (Hz)		SRF (MHz) min.	RDC ( $\Omega$ ) max.	IDC (A) max.
			L	Q			
RLB0912-1R0ML	1.0 $\pm$ 20 %	30	1 k	7.960 M	88.0	0.010	6.0
RLB0912-1R5ML	1.5 $\pm$ 20 %	30	1 k	7.960 M	78.0	0.008	5.4
RLB0912-2R2ML	2.2 $\pm$ 20 %	30	1 k	7.960 M	63.0	0.010	4.5
RLB0912-3R3ML	3.3 $\pm$ 20 %	30	1 k	7.960 M	50.0	0.018	3.6
RLB0912-4R7ML	4.7 $\pm$ 20 %	30	1 k	7.960 M	41.0	0.022	3.1
RLB0912-6R8ML	6.8 $\pm$ 20 %	30	1 k	7.960 M	33.0	0.028	2.5
RLB0912-100KL	10.0 $\pm$ 10 %	60	1 k	2.520 M	27.0	0.043	2.1
RLB0912-150KL	15.0 $\pm$ 10 %	50	1 k	2.520 M	21.0	0.056	1.7
RLB0912-220KL	22.0 $\pm$ 10 %	50	1 k	2.520 M	17.0	0.086	1.4
RLB0912-330KL	33.0 $\pm$ 10 %	45	1 k	2.520 M	13.0	0.140	1.1
RLB0912-470KL	47.0 $\pm$ 10 %	40	1 k	2.520 M	11.0	0.170	0.96
RLB0912-680KL	68.0 $\pm$ 10 %	35	1 k	2.520 M	9.0	0.280	0.79
RLB0912-101KL	100.0 $\pm$ 10 %	55	1 k	0.796 M	7.2	0.330	0.66
RLB0912-151KL	150.0 $\pm$ 10 %	40	1 k	0.796 M	5.7	0.560	0.53
RLB0912-221KL	220.0 $\pm$ 10 %	30	1 k	0.796 M	4.5	0.720	0.44
RLB0912-331KL	330.0 $\pm$ 10 %	25	1 k	0.796 M	3.6	1.100	0.36
RLB0912-471KL	470.0 $\pm$ 10 %	25	1 k	0.796 M	2.9	1.700	0.30
RLB0912-681KL	680.0 $\pm$ 10 %	25	1 k	0.796 M	2.3	2.300	0.25
RLB0912-102KL	1000.0 $\pm$ 10 %	55	1 k	0.252 M	1.9	4.300	0.20

Packaging: 200 pieces per bag; available in ammo-pak (use Model RLH0912) - 1000 pieces per box

Specifications are subject to change without notice.  
Customers should verify actual device performance in their specific applications.

# RLB Series Radial Inductors

**BOURNS®**

## RLB0914 Series Electrical Characteristics

BOURNS Part No.	Inductance ( $\mu$ H)	Q ref.	Test freq. (MHz) L, Q	SRF (MHz) min.	RDC ( $\Omega$ ) max.	IDC (A) max.
RLB0914-3R3ML	3.3 $\pm$ 20 %	20	7.960	70.0	0.027	3.60
RLB0914-4R7ML	4.7 $\pm$ 20 %	20	7.960	50.0	0.033	3.20
RLB0914-6R8ML	6.8 $\pm$ 20 %	20	7.960	30.0	0.039	3.00
RLB0914-100KL	10.0 $\pm$ 10 %	50	2.520	20.0	0.048	2.70
RLB0914-120KL	12.0 $\pm$ 10 %	50	2.520	15.0	0.055	2.50
RLB0914-150KL	15.0 $\pm$ 10 %	50	2.520	10.0	0.060	2.40
RLB0914-180KL	18.0 $\pm$ 10 %	40	2.520	9.5	0.065	2.30
RLB0914-220KL	22.0 $\pm$ 10 %	40	2.520	9.0	0.090	1.90
RLB0914-270KL	27.0 $\pm$ 10 %	40	2.520	8.5	0.110	1.80
RLB0914-330KL	33.0 $\pm$ 10 %	40	2.520	8.0	0.120	1.70
RLB0914-390KL	39.0 $\pm$ 10 %	30	2.520	7.0	0.130	1.60
RLB0914-470KL	47.0 $\pm$ 10 %	30	2.520	6.0	0.140	1.50
RLB0914-560KL	56.0 $\pm$ 10 %	30	2.520	5.0	0.200	1.30
RLB0914-680KL	68.0 $\pm$ 10 %	30	2.520	4.5	0.210	1.20
RLB0914-820KL	82.0 $\pm$ 10 %	30	2.520	4.0	0.230	1.10
RLB0914-101KL	100.0 $\pm$ 10 %	30	0.796	3.5	0.280	1.00
RLB0914-121KL	120.0 $\pm$ 10 %	30	0.796	3.0	0.320	0.90
RLB0914-151KL	150.0 $\pm$ 10 %	30	0.796	2.8	0.370	0.80
RLB0914-181KL	180.0 $\pm$ 10 %	30	0.796	2.6	0.540	0.75
RLB0914-221KL	220.0 $\pm$ 10 %	20	0.796	2.4	0.600	0.70
RLB0914-271KL	270.0 $\pm$ 10 %	20	0.796	2.2	0.680	0.65
RLB0914-331KL	330.0 $\pm$ 10 %	20	0.796	2.0	0.760	0.60
RLB0914-391KL	390.0 $\pm$ 10 %	20	0.796	1.9	0.850	0.55
RLB0914-471KL	470.0 $\pm$ 10 %	20	0.796	1.8	1.300	0.50
RLB0914-561KL	560.0 $\pm$ 10 %	20	0.796	1.7	1.400	0.45
RLB0914-681KL	680.0 $\pm$ 10 %	20	0.796	1.6	1.600	0.40
RLB0914-821KL	820.0 $\pm$ 10 %	20	0.796	1.5	1.800	0.35
RLB0914-102KL	1000.0 $\pm$ 10 %	40	0.252	1.3	2.100	0.30

Packaging: 200 pieces per bag

# RLB Series Radial Inductors

## RLB1314 Series Electrical Characteristics

BOURNS Part No.	Inductance ( $\mu$ H)	Q Ref.	Test freq. (Hz)		SRF (MHz) Typ.	RDC ( $\Omega$ ) max.	IDC (A) max.	W Dia.	F
			L	Q					
RLB1314-3R3ML	3.3 $\pm$ 20 %	90	1 k	7.96 M	59.00	0.008	5.600	$\frac{0.8 \pm 0.05}{(.032 \pm .002)}$	$\frac{9.0 \pm 1.0}{(.354 \pm .04)}$
RLB1314-4R7ML	4.7 $\pm$ 20 %	100	1 k	7.96 M	45.00	0.009	4.700	$\frac{0.8 \pm 0.05}{(.032 \pm .002)}$	$\frac{9.0 \pm 1.0}{(.354 \pm .04)}$
RLB1314-6R8ML	6.8 $\pm$ 20 %	80	1 k	7.96 M	34.00	0.012	3.900	$\frac{0.7 \pm 0.05}{(.028 \pm .002)}$	$\frac{9.0 \pm 1.0}{(.354 \pm .04)}$
RLB1314-100ML	10.0 $\pm$ 20 %	140	1 k	2.52 M	26.00	0.015	3.200	$\frac{0.7 \pm 0.05}{(.028 \pm .002)}$	$\frac{9.0 \pm 1.0}{(.354 \pm .04)}$
RLB1314-150ML	15.0 $\pm$ 20 %	120	1 k	2.52 M	19.00	0.019	2.600	$\frac{0.7 \pm 0.05}{(.028 \pm .002)}$	$\frac{9.0 \pm 1.0}{(.354 \pm .04)}$
RLB1314- 220KL	22.0 $\pm$ 10 %	110	1 k	2.52 M	14.00	0.026	2.200	$\frac{0.7 \pm 0.05}{(.028 \pm .002)}$	$\frac{9.0 \pm 1.0}{(.354 \pm .04)}$
RLB1314-330KL	33.0 $\pm$ 10 %	100	1 k	2.52 M	10.00	0.045	1.800	$\frac{0.6 \pm 0.05}{(.024 \pm .002)}$	$\frac{9.0 \pm 1.0}{(.354 \pm .04)}$
RLB1314-470KL	47.0 $\pm$ 10 %	90	1 k	2.52 M	8.30	0.056	1.500	$\frac{0.6 \pm 0.05}{(.024 \pm .002)}$	$\frac{9.0 \pm 1.0}{(.354 \pm .04)}$
RLB1314-680KL	68.0 $\pm$ 10 %	80	1 k	2.52 M	6.70	0.092	1.200	$\frac{0.8 \pm 0.05}{(.032 \pm .002)}$	$\frac{7.0 \pm 0.8}{(.276 \pm .032)}$
RLB1314-101KL	100.0 $\pm$ 10 %	70	1 k	796 K	5.40	0.120	1.000	$\frac{0.8 \pm 0.05}{(.032 \pm .002)}$	$\frac{7.0 \pm 0.8}{(.276 \pm .032)}$
RLB1314-151KL	150.0 $\pm$ 10 %	70	1 k	796 K	4.30	0.200	0.820	$\frac{0.8 \pm 0.05}{(.032 \pm .002)}$	$\frac{7.0 \pm 0.8}{(.276 \pm .032)}$
RLB1314-221KL	220.0 $\pm$ 10 %	40	1 k	796 K	3.40	0.250	0.680	$\frac{0.8 \pm 0.05}{(.032 \pm .002)}$	$\frac{7.0 \pm 0.8}{(.276 \pm .032)}$
RLB1314-331KL	330.0 $\pm$ 10 %	40	1 k	796 K	2.70	0.420	0.550	$\frac{0.8 \pm 0.05}{(.032 \pm .002)}$	$\frac{7.0 \pm 0.8}{(.276 \pm .032)}$
RLB1314-471KL	470.0 $\pm$ 10 %	30	1 k	796 K	2.30	0.510	0.460	$\frac{0.8 \pm 0.05}{(.032 \pm .002)}$	$\frac{7.0 \pm 0.8}{(.276 \pm .032)}$
RLB1314-681KL	680.0 $\pm$ 10 %	30	1 k	796 K	1.90	0.790	0.380	$\frac{0.8 \pm 0.05}{(.032 \pm .002)}$	$\frac{7.0 \pm 0.8}{(.276 \pm .032)}$
RLB1314-102KL	1000.0 $\pm$ 10 %	40	1 k	252 K	1.60	1.300	0.310	$\frac{0.8 \pm 0.05}{(.032 \pm .002)}$	$\frac{7.0 \pm 0.8}{(.276 \pm .032)}$
RLB1314-152KL	1500.0 $\pm$ 10 %	30	1 k	252 K	1.30	1.700	0.250	$\frac{0.8 \pm 0.05}{(.032 \pm .002)}$	$\frac{7.0 \pm 0.8}{(.276 \pm .032)}$
RLB1314-222KL	2200.0 $\pm$ 10 %	60	1 k	252 K	1.10	2.900	0.210	$\frac{0.8 \pm 0.05}{(.032 \pm .002)}$	$\frac{7.0 \pm 0.8}{(.276 \pm .032)}$
RLB1314-332KL	3300.0 $\pm$ 10 %	50	1 k	252 K	0.90	3.700	0.170	$\frac{0.8 \pm 0.05}{(.032 \pm .002)}$	$\frac{7.0 \pm 0.8}{(.276 \pm .032)}$
RLB1314-472KL	4700.0 $\pm$ 10 %	50	1 k	252 K	0.76	5.600	0.140	$\frac{0.8 \pm 0.05}{(.032 \pm .002)}$	$\frac{7.0 \pm 0.8}{(.276 \pm .032)}$
RLB1314-682KL	6800.0 $\pm$ 10 %	60	1 k	252 K	0.65	9.400	0.120	$\frac{0.8 \pm 0.05}{(.032 \pm .002)}$	$\frac{7.0 \pm 0.8}{(.276 \pm .032)}$
RLB1314-103KL	10000.0 $\pm$ 10 %	80	1 k	79.6 K	0.53	12.000	0.100	$\frac{0.8 \pm 0.05}{(.032 \pm .002)}$	$\frac{7.0 \pm 0.8}{(.276 \pm .032)}$
RLB1314-153KL	15000.0 $\pm$ 10 %	70	1 k	79.6 K	0.41	15.000	0.082	$\frac{0.8 \pm 0.05}{(.032 \pm .002)}$	$\frac{7.0 \pm 0.8}{(.276 \pm .032)}$

DIMENSIONS ARE:  $\frac{\text{MM}}{\text{(INCHES)}}$

Packaging: RLB1314 (3R3M to 470K) = 150 pieces per bag; RLB1314 (680K to 153K) = 130 pieces per bag.

REV. 09/09

Specifications are subject to change without notice.

Customers should verify actual device performance in their specific applications.

\*RoHS COMPLIANT

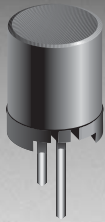

**BOURNS®**

## Features

- High inductance up to 47 mH
- High Q level
- RoHS compliant\*

## FSR1013 Series - Radial Shielded Inductors

### Materials

Core .....	Ferrite POT core
Wire .....	Enamelled copper wire
Bobbin .....	Phenolic
Terminal .....	Cu/Sn
Adhesive .....	Epoxy resin
Temperature Rise .....	40 °C max. at rated current
Operating Temperature .....	-40 °C to +105 °C
Storage Temperature .....	-40 °C to +105 °C
Packaging .....	110 pcs. per bag

### Dimensions

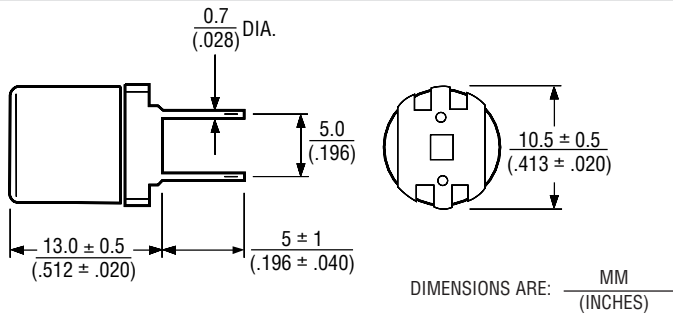

### Electrical Characteristics

BOURNS Part No.	Inductance (mH)	Q min.	Test freq. (Hz)		SRF (kHz) min.	RDC (Ω) max.	Rated Curr. IDC (mA)
			L	Q			
FSR 1013-102KL	1.0 ± 10 %	40	1 k	252.0 k	740	4.0	150
FSR 1013-122KL	1.2 ± 10 %	40	1 k	252.0 k	670	5.0	140
FSR 1013-152KL	1.5 ± 10 %	40	1 k	252.0 k	500	6.0	130
FSR 1013-182KL	1.8 ± 10 %	40	1 k	252.0 k	480	7.0	115
FSR 1013-222KL	2.2 ± 10 %	40	1 k	252.0 k	410	10.0	100
FSR 1013-272KL	2.7 ± 10 %	40	1 k	252.0 k	390	11.0	95
FSR 1013-332KL	3.3 ± 10 %	30	1 k	252.0 k	350	12.0	85
FSR 1013-392KL	3.9 ± 10 %	30	1 k	252.0 k	340	13.0	80
FSR 1013-472KL	4.7 ± 10 %	30	1 k	252.0 k	320	23.0	70
FSR 1013-562KL	5.6 ± 10 %	30	1 k	252.0 k	310	25.0	65
FSR 1013-682KL	6.8 ± 10 %	20	1 k	252.0 k	280	30.0	60
FSR 1013-822KL	8.2 ± 10 %	20	1 k	252.0 k	260	32.0	50
FSR 1013-103KL	10.0 ± 10 %	50	1 k	79.6 k	240	35.0	45
FSR 1013-123KL	12.0 ± 10 %	50	1 k	79.6 k	210	50.0	40
FSR 1013-153KL	15.0 ± 10 %	50	1 k	79.6 k	190	58.0	38
FSR 1013-183KL	18.0 ± 10 %	50	1 k	79.6 k	180	63.0	35
FSR 1013-223KL	22.0 ± 10 %	40	1 k	79.6 k	140	90.0	30
FSR 1013-273KL	27.0 ± 10 %	40	1 k	79.6 k	130	100.0	28
FSR 1013-333KL	33.0 ± 10 %	40	1 k	79.6 k	125	115.0	25
FSR 1013-393KL	39.0 ± 10 %	30	1 k	79.6 k	120	185.0	23
FSR 1013-473KL	47.0 ± 10 %	30	1 k	79.6 k	110	205.0	22

REV. 09/09

\*RoHS Directive 2002/95/EC Jan 27 2003 including Annex Specifications are subject to change without notice.

Customers should verify actual device performance in their specific applications.

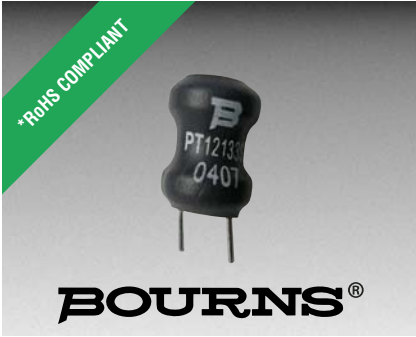

## Features

- Low cost, high quality
- Excellent temperature stability
- High currents
- E12 series 100  $\mu$ H to 33mH
- Open construction
- RoHS compliant\*

## PT121 Series - Radial High Q Inductors

### Electrical Specifications (@ 25 °C)

Part Number	Inductance Typical (1) mH -10 %	Q (ref.)	Measure frequency Q and Inductance kHz	Self Resonant frequency MHz min. (2)	DCR $\Omega$ (max.)	Rated I DC mA (max.)
PT12110SL	0.10	80	796.0	5.30	2.0	200
PT12111SL	0.12	80	796.0	4.50	2.0	200
PT12112SL	0.15	80	796.0	3.80	2.0	200
PT12113SL	0.18	80	796.0	3.30	3.0	200
PT12114SL	0.22	80	796.0	2.90	3.0	200
PT12115SL	0.27	80	796.0	2.60	3.0	200
PT12116SL	0.33	80	796.0	2.30	4.0	200
PT12117SL	0.39	80	796.0	2.10	4.0	200
PT12118SL	0.47	80	796.0	1.90	4.0	200
PT12119SL	0.56	80	796.0	1.70	4.0	200
PT12120SL	0.60	80	796.0	1.60	4.0	200
PT12121SL	1.00	90	252.0	1.30	6.0	150
PT12123SL	1.20	90	252.0	1.20	9.0	150
PT12124SL	1.50	90	252.0	1.10	9.0	150
PT12125SL	1.80	90	252.0	1.00	9.0	100
PT12126SL	2.20	90	252.0	0.90	13.0	100
PT12127SL	2.70	90	252.0	0.80	13.0	100
PT12128SL	3.30	90	252.0	0.70	13.0	100
PT12129SL	3.90	90	252.0	0.70	13.0	50
PT12130SL	4.70	90	252.0	0.60	18.0	50
PT12131SL	5.60	90	252.0	0.60	18.0	50
PT12132SL	6.80	90	252.0	0.50	26.0	50
PT12133SL	8.20	90	252.0	0.50	26.0	50
PT12134SL	10.00	100	79.6	0.40	40.0	40
PT12135SL	12.00	100	79.6	0.40	40.0	40
PT12136SL	15.00	100	79.6	0.40	60.0	40
PT12137SL	18.00	100	79.6	0.30	60.0	30
PT12138SL	22.00	100	79.6	0.30	80.0	30
PT12139SL	27.00	100	79.6	0.30	80.0	30
PT12140SL	33.00	100	79.6	0.30	80.0	30

#### NOTES:

- (1) Version J: Inductance Value  $\pm 5$  % is also available. Please insert 'J' after 'S' in part number if Inductance Value  $\pm 5$  % is required (i.e. PT12110SJL).
- (2) Measurements are made at 25 °C using HP4277A LCZ Meter Self Resonant Frequency is for reference only.

Full encapsulated units with Epoxy Resin are also available. Please consult factory for details.

### General Specifications

Terminal.....Cu/Sn  
 Operating Temperature Range  
 .....-20 °C to +80 °C  
 Storage Temperature Range  
 .....-25 °C to +85 °C

### Product Dimensions

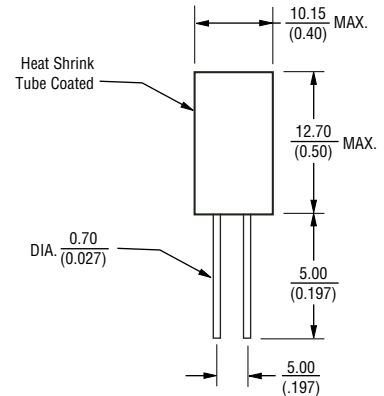

### Recommended PCB Layout

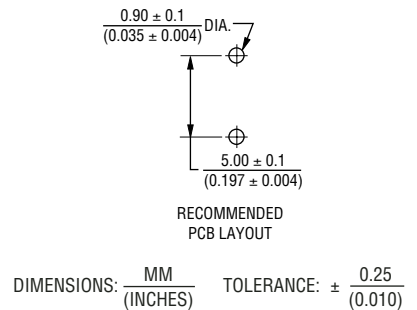

### Electrical Schematic

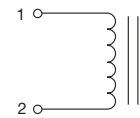

Schematic

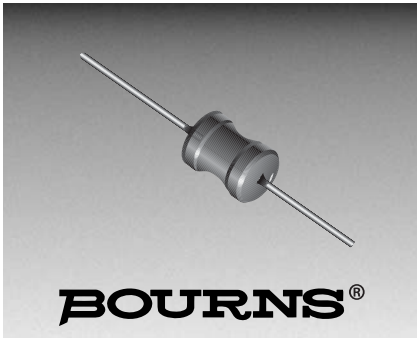

**BOURNS®**

### Features

- High current up to 5 A
- RoHS compliant\*

### Applications

- DC/DC onverters
- Power supplies
- General use

## LPA Series Axial Power Inductors

### General Specifications

Temperature Rise .....45 °C max. at rated current  
 Operating Temperature...-40 °C to +85 °C  
 Storage Temperature ..-40 °C to +105 °C

### Materials

Core Material .....Ferrite DR core  
 Wire .....Enameled copper wire  
 Terminal .....Cu/Sn  
 Tube.....Shrinkable tube 125 °C, 600 V

### Product Dimensions

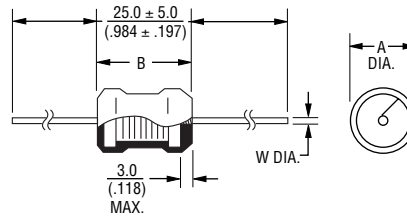

DIMENSIONS ARE:  $\frac{\text{MM}}{\text{(INCHES)}}$

### Electrical Schematic

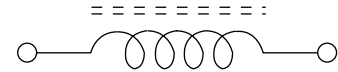

### Electrical Characteristics and Product Dimensions

BOURNS Part No.	Inductance ( $\mu\text{H}$ ) 1KHz	RDC ( $\Omega$ ) max.	IDC (A) max.	Dimensions		
				A max.	B max.	W dia.
LPA0618-100KL	10 $\pm$ 10 %	0.075	2.00	$\frac{6.0}{(.236)}$	$\frac{18.0}{(.709)}$	$\frac{0.65 \pm 0.05}{(.026 \pm .002)}$
LPA0618-250KL	25 $\pm$ 10 %	0.150	1.20	$\frac{6.0}{(.236)}$	$\frac{18.0}{(.709)}$	$\frac{0.65 \pm 0.05}{(.026 \pm .002)}$
LPA0618-500KL	50 $\pm$ 10 %	0.200	0.80	$\frac{6.0}{(.236)}$	$\frac{18.0}{(.709)}$	$\frac{0.65 \pm 0.05}{(.026 \pm .002)}$
LPA0618-101KL	100 $\pm$ 10 %	0.300	0.60	$\frac{6.0}{(.236)}$	$\frac{18.0}{(.709)}$	$\frac{0.65 \pm 0.05}{(.026 \pm .002)}$
LPA0618-251KL	250 $\pm$ 10 %	1.000	0.40	$\frac{6.0}{(.236)}$	$\frac{18.0}{(.709)}$	$\frac{0.65 \pm 0.05}{(.026 \pm .002)}$
LPA0618-501KL	500 $\pm$ 10 %	2.000	0.25	$\frac{6.0}{(.236)}$	$\frac{18.0}{(.709)}$	$\frac{0.65 \pm 0.05}{(.026 \pm .002)}$
LPA0618-102KL	1000 $\pm$ 10 %	3.000	0.20	$\frac{6.0}{(.236)}$	$\frac{18.0}{(.709)}$	$\frac{0.65 \pm 0.05}{(.026 \pm .002)}$
LPA1020-100KL	10 $\pm$ 10 %	0.050	3.50	$\frac{10.0}{(.394)}$	$\frac{20.0}{(.787)}$	$\frac{0.65 \pm 0.05}{(.026 \pm .002)}$
LPA1020-250KL	25 $\pm$ 10 %	0.085	2.50	$\frac{10.0}{(.394)}$	$\frac{20.0}{(.787)}$	$\frac{0.65 \pm 0.05}{(.026 \pm .002)}$
LPA1020-500KL	50 $\pm$ 10 %	0.120	2.00	$\frac{10.0}{(.394)}$	$\frac{20.0}{(.787)}$	$\frac{0.65 \pm 0.05}{(.026 \pm .002)}$
LPA1020-101KL	100 $\pm$ 10 %	0.180	1.40	$\frac{10.0}{(.394)}$	$\frac{20.0}{(.787)}$	$\frac{0.65 \pm 0.05}{(.026 \pm .002)}$
LPA1020-251KL	250 $\pm$ 10 %	0.500	0.80	$\frac{10.0}{(.394)}$	$\frac{20.0}{(.787)}$	$\frac{0.65 \pm 0.05}{(.026 \pm .002)}$
LPA1020-501KL	500 $\pm$ 10 %	1.000	0.60	$\frac{10.0}{(.394)}$	$\frac{20.0}{(.787)}$	$\frac{0.65 \pm 0.05}{(.026 \pm .002)}$
LPA1020-102KL	1000 $\pm$ 10 %	2.200	0.40	$\frac{10.0}{(.394)}$	$\frac{20.0}{(.787)}$	$\frac{0.65 \pm 0.05}{(.026 \pm .002)}$
LPA1226-100KL	10 $\pm$ 10 %	0.030	5.0	$\frac{12.0}{(.472)}$	$\frac{26.0}{(1.024)}$	$\frac{0.8 \pm 0.05}{(.031 \pm .002)}$
LPA1226-250KL	25 $\pm$ 10 %	0.045	4.0	$\frac{12.0}{(.472)}$	$\frac{26.0}{(1.024)}$	$\frac{0.8 \pm 0.05}{(.031 \pm .002)}$
LPA1226-500KL	50 $\pm$ 10 %	0.080	3.0	$\frac{12.0}{(.472)}$	$\frac{26.0}{(1.024)}$	$\frac{0.8 \pm 0.05}{(.031 \pm .002)}$
LPA1226-101KL	100 $\pm$ 10 %	0.125	2.0	$\frac{12.0}{(.472)}$	$\frac{26.0}{(1.024)}$	$\frac{0.8 \pm 0.05}{(.031 \pm .002)}$
LPA1226-251KL	250 $\pm$ 10 %	0.300	1.2	$\frac{12.0}{(.472)}$	$\frac{26.0}{(1.024)}$	$\frac{0.8 \pm 0.05}{(.031 \pm .002)}$
LPA1226-501KL	500 $\pm$ 10 %	0.500	0.8	$\frac{12.0}{(.472)}$	$\frac{26.0}{(1.024)}$	$\frac{0.8 \pm 0.05}{(.031 \pm .002)}$
LPA1226-102KL	1000 $\pm$ 10 %	1.200	0.6	$\frac{12.0}{(.472)}$	$\frac{26.0}{(1.024)}$	$\frac{0.8 \pm 0.05}{(.031 \pm .002)}$

REV. 09/09

\*RoHS Directive 2002/95/EC Jan 27 2003 including Annex  
 Specifications are subject to change without notice.

Customers should verify actual device performance in their specific applications.



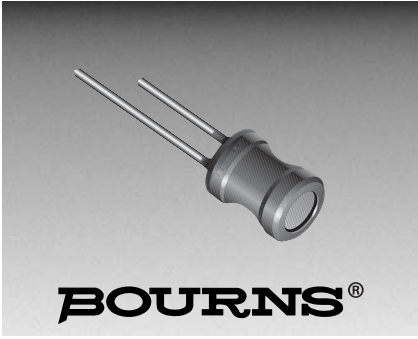

**BOURNS®**

### Features

- High current up to 10 A
- RoHS compliant\*

### Applications

- DC/DC converters
- Power supplies

## LPV Series Radial Power Inductors

#### General Specifications

Temperature Rise .....45 °C max. at rated current  
 Operating Temperature...-40 °C to +85 °C  
 Storage Temperature ..-40 °C to +105 °C

#### Materials

Core Material .....Ferrite DR core  
 Wire .....Enameled copper wire  
 Terminal .....Cu/Sn  
 Tube.....Shrinkable tube 125 °C, 600 V

#### Product Dimensions

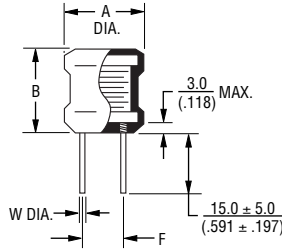

DIMENSIONS ARE:  $\frac{\text{MM}}{\text{(INCHES)}}$

#### Electrical Schematic

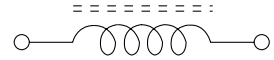

#### Electrical Characteristics and Product Dimensions

BOURNS Part No.	Inductance ( $\mu\text{H}$ ) 1KHz	RDC ( $\Omega$ ) max.	IDC (A) max.	Dimensions			
				A max.	B max.	F	W dia.
LPV1620-100ML	10 $\pm$ 20 %	0.024	5.0	$\frac{16.0}{(.630)}$	$\frac{20.0}{(.787)}$	$\frac{8.0 \pm 1.5}{(.315 \pm .059)}$	$\frac{1.0 \pm 0.1}{(.039 \pm .004)}$
LPV1620-250KL	25 $\pm$ 10 %	0.040	4.0	$\frac{16.0}{(.630)}$	$\frac{20.0}{(.787)}$	$\frac{8.0 \pm 1.5}{(.315 \pm .059)}$	$\frac{1.0 \pm 0.1}{(.039 \pm .004)}$
LPV1620-500KL	50 $\pm$ 10 %	0.060	3.0	$\frac{16.0}{(.630)}$	$\frac{20.0}{(.787)}$	$\frac{8.0 \pm 1.5}{(.315 \pm .059)}$	$\frac{1.0 \pm 0.1}{(.039 \pm .004)}$
LPV1620-101KL	100 $\pm$ 10 %	0.090	2.0	$\frac{16.0}{(.630)}$	$\frac{20.0}{(.787)}$	$\frac{8.0 \pm 1.5}{(.315 \pm .059)}$	$\frac{1.0 \pm 0.1}{(.039 \pm .004)}$
LPV1620--251KL	250 $\pm$ 10 %	0.180	1.5	$\frac{16.0}{(.630)}$	$\frac{20.0}{(.787)}$	$\frac{8.0 \pm 1.5}{(.315 \pm .059)}$	$\frac{1.0 \pm 0.1}{(.039 \pm .004)}$
LPV1620-501KL	500 $\pm$ 10 %	0.400	1.0	$\frac{16.0}{(.630)}$	$\frac{20.0}{(.787)}$	$\frac{8.0 \pm 1.5}{(.315 \pm .059)}$	$\frac{1.0 \pm 0.1}{(.039 \pm .004)}$
LPV1620-102KL	1000 $\pm$ 10 %	0.800	0.7	$\frac{16.0}{(.630)}$	$\frac{20.0}{(.787)}$	$\frac{8.0 \pm 1.5}{(.315 \pm .059)}$	$\frac{1.0 \pm 0.1}{(.039 \pm .004)}$
LPV1823-100M	10 $\pm$ 20 %	0.009	8.0	$\frac{18.0}{(.709)}$	$\frac{23.0}{(.906)}$	$\frac{14.0 \pm 1.5}{(.551 \pm .059)}$	$\frac{1.2 \pm 0.1}{(.047 \pm .004)}$
LPV1823-250KL	25 $\pm$ 10 %	0.022	6.0	$\frac{18.0}{(.709)}$	$\frac{23.0}{(.906)}$	$\frac{14.0 \pm 1.5}{(.551 \pm .059)}$	$\frac{1.0 \pm 0.1}{(.039 \pm .004)}$
LPV1823-500KL	50 $\pm$ 10 %	0.036	4.0	$\frac{18.0}{(.709)}$	$\frac{23.0}{(.906)}$	$\frac{14.0 \pm 1.5}{(.551 \pm .059)}$	$\frac{1.0 \pm 0.1}{(.039 \pm .004)}$
LPV1823-101KL	100 $\pm$ 10 %	0.090	3.0	$\frac{18.0}{(.709)}$	$\frac{23.0}{(.906)}$	$\frac{9.0 \pm 1.5}{(.354 \pm .059)}$	$\frac{1.0 \pm 0.1}{(.039 \pm .004)}$
LPV1823-251KL	250 $\pm$ 10 %	0.150	2.0	$\frac{18.0}{(.709)}$	$\frac{23.0}{(.906)}$	$\frac{9.0 \pm 1.5}{(.354 \pm .059)}$	$\frac{1.0 \pm 0.1}{(.039 \pm .004)}$
LPV1823-501KL	500 $\pm$ 10 %	0.300	1.2	$\frac{18.0}{(.709)}$	$\frac{23.0}{(.906)}$	$\frac{9.0 \pm 1.5}{(.354 \pm .059)}$	$\frac{1.0 \pm 0.1}{(.039 \pm .004)}$
LPV1823-102KL	1000 $\pm$ 10 %	0.600	1.0	$\frac{18.0}{(.709)}$	$\frac{23.0}{(.906)}$	$\frac{9.0 \pm 1.5}{(.354 \pm .059)}$	$\frac{1.0 \pm 0.1}{(.039 \pm .004)}$
LPV2023-100M	10 $\pm$ 20 %	0.008	10.0	$\frac{20.0}{(.787)}$	$\frac{23.0}{(.906)}$	$\frac{15.5 \pm 1.5}{(.610 \pm .059)}$	$\frac{1.3 \pm 0.1}{(.051 \pm .004)}$
LPV2023-500KL	50 $\pm$ 10 %	0.032	5.0	$\frac{20.0}{(.787)}$	$\frac{23.0}{(.906)}$	$\frac{15.5 \pm 1.5}{(.610 \pm .059)}$	$\frac{1.0 \pm 0.1}{(.039 \pm .004)}$
LPV2023-101KL	100 $\pm$ 10 %	0.060	4.0	$\frac{20.0}{(.787)}$	$\frac{23.0}{(.906)}$	$\frac{15.5 \pm 1.5}{(.610 \pm .059)}$	$\frac{1.0 \pm 0.1}{(.039 \pm .004)}$
LPV2023-251KL	250 $\pm$ 10 %	0.140	2.5	$\frac{20.0}{(.787)}$	$\frac{23.0}{(.906)}$	$\frac{12.5 \pm 1.5}{(.492 \pm .059)}$	$\frac{1.0 \pm 0.1}{(.039 \pm .004)}$
LPV2023-501KL	500 $\pm$ 10 %	0.280	1.5	$\frac{20.0}{(.787)}$	$\frac{23.0}{(.906)}$	$\frac{12.5 \pm 1.5}{(.492 \pm .059)}$	$\frac{1.0 \pm 0.1}{(.039 \pm .004)}$
LPV2023-102KL	1000 $\pm$ 10 %	0.550	1.2	$\frac{20.0}{(.787)}$	$\frac{23.0}{(.906)}$	$\frac{12.5 \pm 1.5}{(.492 \pm .059)}$	$\frac{1.0 \pm 0.1}{(.039 \pm .004)}$
LPV2023-202KL	2000 $\pm$ 10 %	1.200	0.8	$\frac{20.0}{(.787)}$	$\frac{23.0}{(.906)}$	$\frac{12.5 \pm 1.5}{(.492 \pm .059)}$	$\frac{1.0 \pm 0.1}{(.039 \pm .004)}$

REV. 09/09

\*RoHS Directive 2002/95/EC Jan 27 2003 including Annex

Specifications are subject to change without notice.

Customers should verify actual device performance in their specific applications.



---

## **V. Surface Mount Data Line Dual Chokes**

Product Capability Matrix.....	196
Product Specifications	
• <i>DR221 Series Dual Chokes</i> .....	197
• <i>DR331 Series Dual Chokes</i> .....	199

## Surface Mount Data Line Chokes Product Capability Matrix

### Product Selection Guide

Model	L ( $\mu$ H)	I (A)	Winding	Application
DR221-113AE	11	0.25	Bifilar	Can bus
DR221-223AE	22	0.25	Bifilar	Can bus
DR221-333AE	33	0.2	Bifilar	Can bus
DR221-513AE	50	0.2	Bifilar	Can bus
DR221-474AE	47	0.1	Bifilar	Can bus
DR331-113AE	11	0.5	Bifilar	Can bus
DR331-253AE	25	0.5	Sector	Can bus
DR331-513AE	50	0.5	Sector	Can bus
DR331-474AE	47	0.5	Bifilar	Can bus
DR331-105AE	100	0.5	Bifilar	Can bus
DR331-475AE	470	0.2	Bifilar	Can bus
DR332-253E	25	0.5	Sector	Can bus
DR332-513E	51	0.5	Sector	Can bus
DR332-474E	470	0.5	Bifilar	Telecom
DR332-475E	4700	0.2	Bifilar	Telecom

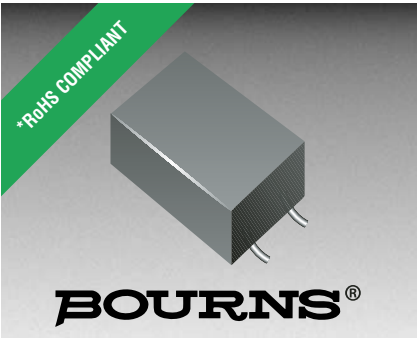

### Features

- Lead free
- RoHS compliant\*
- Sector windings
- Wide frequency range over 500 MHz
- Rated current 0.1 to .025 A
- High quality toroidal core

### Applications

- For the suppression of EMI in data and signal lines, e.g. CAN Bus

## DR221 Series Surface Mount Data Line Chokes

### Electrical Characteristics (@ 25 °C)

Bourns Part Number	L1, L2 @ 10kHz, 0.1 Vrms (μH)	Freq. Range (MHz)	Impedance Min. (Ω)	RDC (Ω) (Each Winding)		Rated Current (mA)
				Max.	Typ.	
DR221-113AE	11.0 +50 %/-30 %	100~500	450	0.18	0.13	250
DR221-223AE	22.0 +50 %/-30 %	40~300	900	0.23	0.17	250
DR221-333AE	33.0 +50 %/-30 %	30~250	1000	0.27	0.20	200
DR221-513AE	50.0 +50 %/-30 %	20~150	1400	0.32	0.24	200
DR221-474AE	470 +50 %/-30 %	2.5~60	1100	0.35	0.28	100

Rated Voltage .....50 Vdc/100 Vac (ref.)  
 Hipot (1 sec.).....500 Vac/60 Hz, 3 mA  
 Operating Temperature ....-40 to +125 °C  
 Storage Temperature .....-40 to +125 °C  
 Temperature Rise  
 .....25 °C max. at rated current  
 Resistance to Solder Heat  
 .....260 °C 10 sec.  
 Core .....Ferrite  
 Wire .....Enamelled copper wire (Class F)  
 Base .....LCP (UL 94V-0)  
 Terminal .....Cu/Ni/Sn  
 Adhesive.....Epoxy resin  
 Weight .....2 g  
 Packaging .....500 pcs. per reel

### Product Dimensions

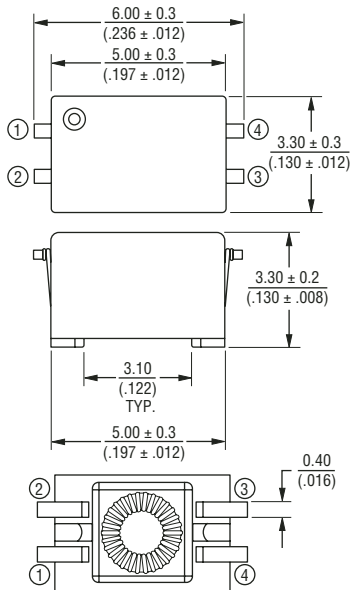

### Recommended PCB Layout

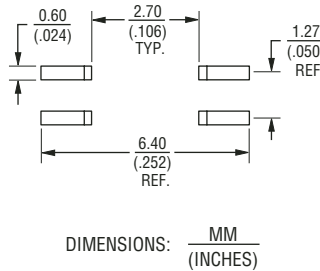

### Schematic

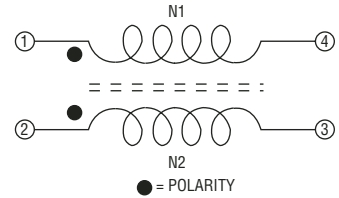

### How to Order

**DR221 - 513 AE**

Model \_\_\_\_\_  
 Value/Tolerance \_\_\_\_\_  
 See Model-Value Table  
 Termination \_\_\_\_\_  
 AE = Cu/Ni/Sn (Lead Free)

### Typical Part Marking

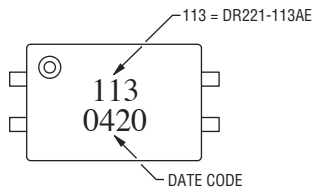

### Solder Profile

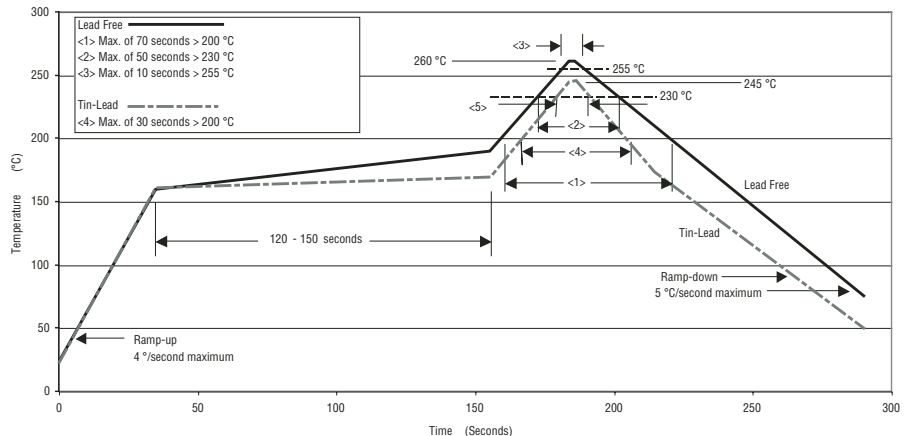

\*RoHS Directive 2002/95/EC Jan 27 2003 including Annex  
 Specifications are subject to change without notice.  
 Customers should verify actual device performance in their specific applications.

# DR221 Series Surface Mount Data Line Chokes

## Packaging Specifications

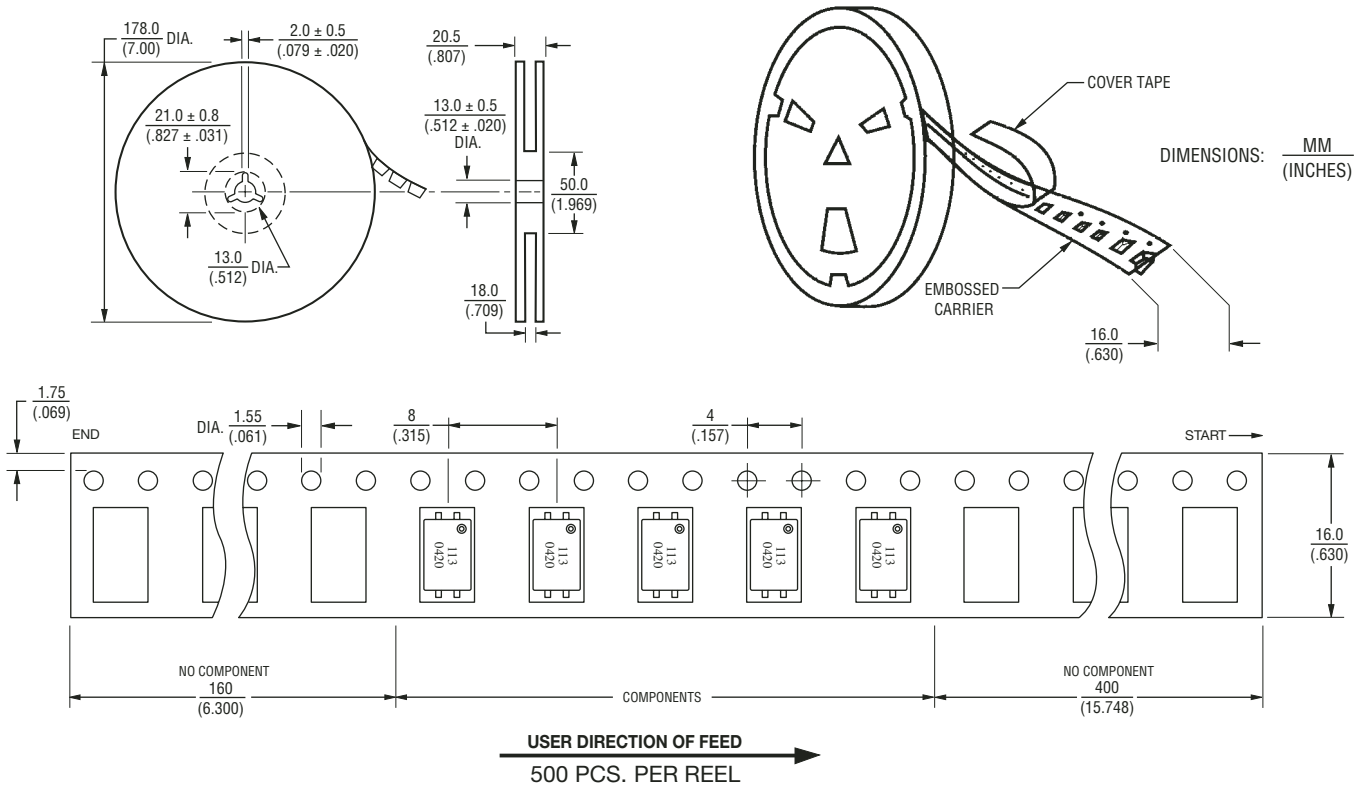

## Impedance vs. Frequency

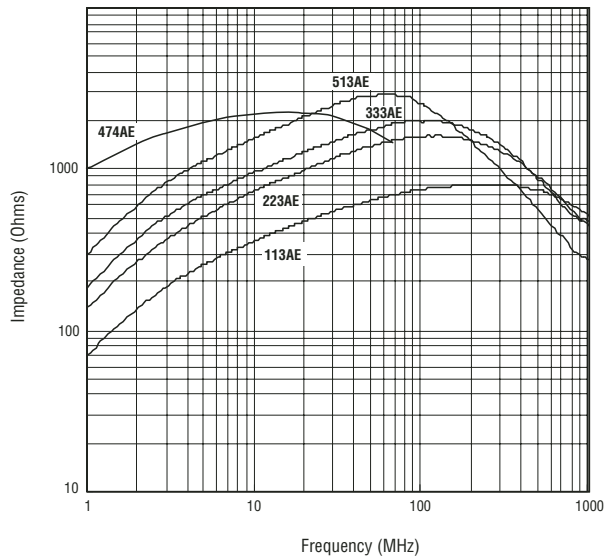



## Features

- RoHS compliant\*
- Bifilar or sector windings
- Wide frequency range over 1000 MHz
- Rated current 0.2 to 0.5A
- Open construction is more economical than DR332 Series

## Applications

- For the suppression of EMI in data and signal lines, e.g. CAN Bus

# DR331 Series Surface Mount Data Line Chokes

### Electrical Characteristics (@ 25 °C)

Bourns Part Number	L (1-4) @ 100 kHz, 0.1 Vrms (μH)	LL (1-4) @ 100 kHz, 0.1 Vrms (Typ.) (2-3 Short)	RDC (Ω) (Winding) Max.	Rated Current Max.	Winding
DR331-113BE	11.0 ±25 %	0.05 μH	0.12	0.5 A	Bifilar
DR331-253AE	25.0 ±25 %	1.50 μH	0.20	0.5 A	Sector
DR331-513AE	51.0 ±25 %	2.00 μH	0.30	0.5 A	Sector
DR331-513BE	51.0 ±25 %	0.60 μH	0.30	0.5 A	Bifilar
DR331-104AE	100.0 ±25 %	0.85 μH	0.10	0.5 A	Sector
DR331-474BE	470.0 ±25 %	0.28 μH	0.28	0.5 A	Bifilar
DR331-105BE	1000.0 ±25 %	0.29 μH	0.40	0.5 A	Bifilar
DR331-225BE	2200.0 ±25 %	0.30 μH	0.70	0.3 A	Bifilar
DR331-475BE	4700.0 ±25 %	0.30 μH	0.70	0.2 A	Bifilar

Rated Voltage .....80 Vdc/42 Vac  
 Hipot (1 sec.).....250 Vac/60 Hz, 3 mA  
 \*Operating Temperature ..-40 to +135 °C  
 \*Storage Temperature .....-40 to +135 °C  
 Temperature Rise  
 .....30 °C max. at rated current  
 Resistance to Solder Heat  
 .....260 °C 10 sec.  
 Core .....Ferrite  
 Wire .....Enamelled copper wire (Class F)  
 Base .....PPHS (UL 94V-0)  
 Terminal .....Cu/Ni/Sn  
 Adhesive.....Epoxy resin  
 Packaging .....1500 pcs. per reel

### Product Dimensions

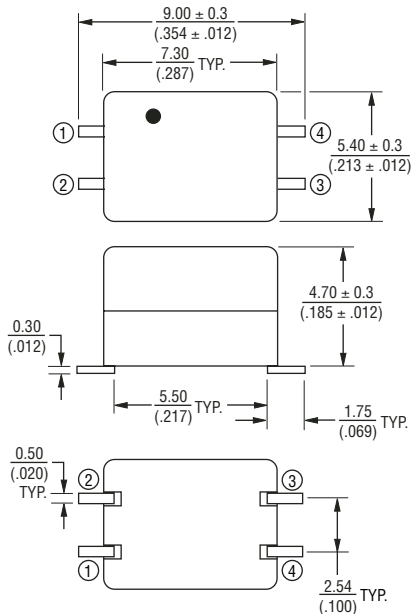

### Recommended PCB Layout

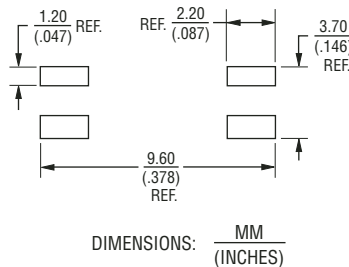

### Schematic

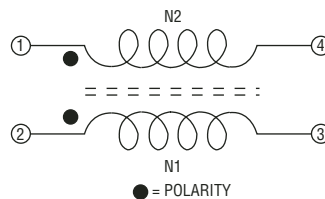

### How to Order

**DR331 - 253 A E**

Model \_\_\_\_\_  
 Value Code \_\_\_\_\_  
 See Model-Value Table  
 Winding Type \_\_\_\_\_  
 A = Sector  
 B = Bifilar  
 Terminal \_\_\_\_\_  
 E = Cu/Ni/Sn (RoHS compliant)

### Typical Part Marking

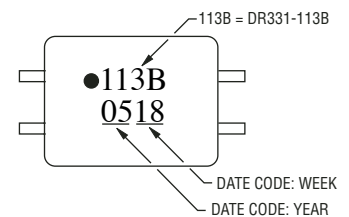

\*RoHS Directive 2002/95/EC Jan 27 2003 including Annex  
 Specifications are subject to change without notice.  
 Customers should verify actual device performance in their specific applications.

# DR331 Series Surface Mount Data Line Chokes

**BOURNS®**

## Solder Profile

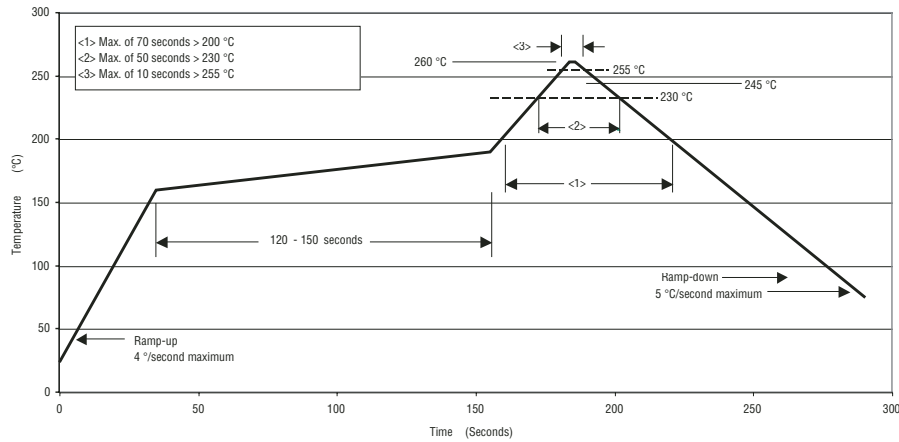

## Impedance vs. Frequency

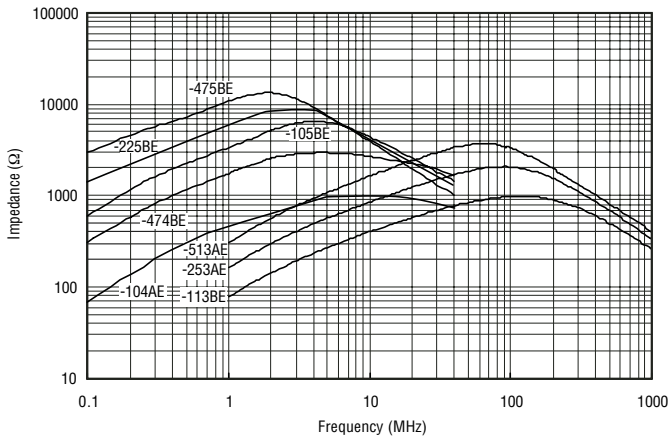

## Insertion Loss vs. Frequency

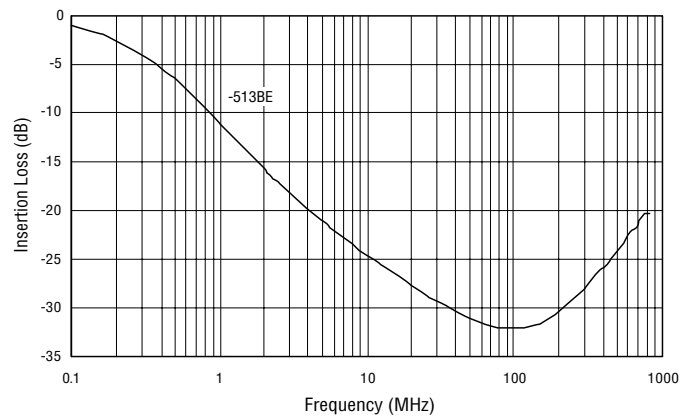
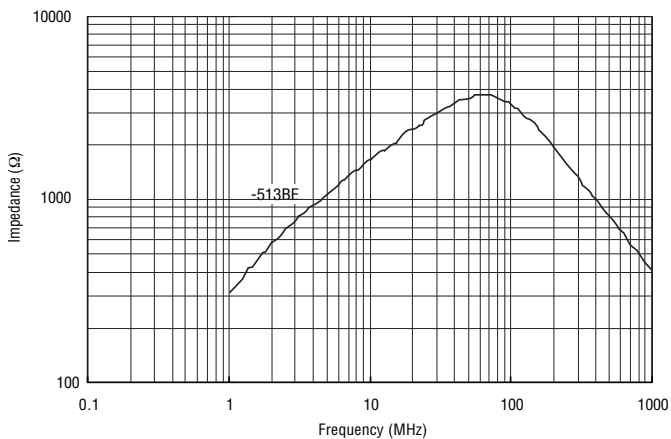
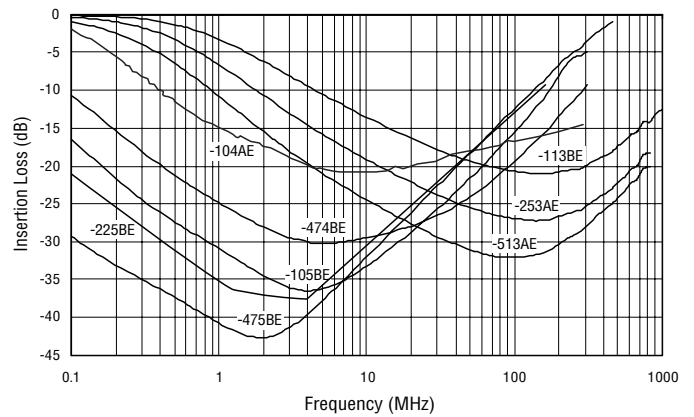

Specifications are subject to change without notice.  
 Customers should verify actual device performance in their specific applications.



# DR331 Series Surface Mount Data Line Chokes

**BOURNS®**

## Packaging Specifications

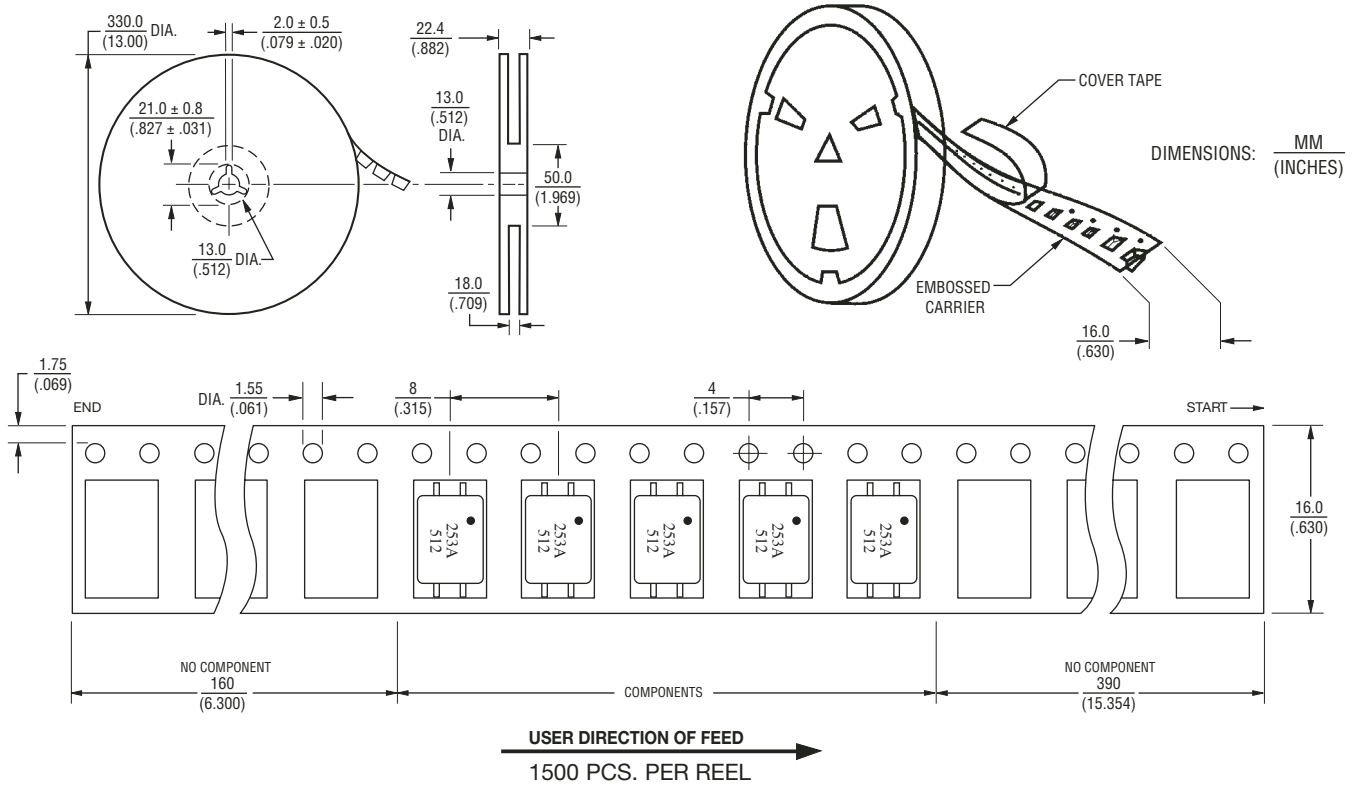

REV. 08/08

Specifications are subject to change without notice.  
Customers should verify actual device performance in their specific applications.











### Worldwide Sales Offices

<b>Country</b>	<b>Phone</b>	<b>Fax</b>
Benelux:	+31 (0)70 300 4333	+31 (0)70 300 4345
Brazil:	+55 11 5505 0601	+55 11 5505 4370
China:	+86 21 64821250	+86 21 64821249
France:	+33 (0)2 5473 5151	+33 (0)2 5473 5156
Germany:	+49 (0)69 800 78212	+49 (0)69 800 78299
India:	+91 484 302483	+91 484 302 287
Ireland:	+353 (0)1276 691087	+353 (0)1276 691088
Italy:	+390 2 389 00041	+390 2 389 00042
Japan:	+81 49 269 3204	+81 49 269 3297
Malaysia (KL Office):	+60 3 71183138	+60 3 71183139
Malaysia (Penang Office):	+60 4 6581771	+60 4 6582771
Singapore:	+65 63461933	+65 63461911
Switzerland:	+41 (0)41 768 5555	+41 (0)41 768 5510
Taiwan:	+886 2 25624117	+886 2 25624116
UK:	+44 (0)1276 691087	+44 (0)1276 691088
USA:	+1-951-781-5500	+1-951-781-5006
Non-Listed European Countries:	+41 (0)41 768 5555	+41 (0)41 768 5510

### Technical Assistance

<b>Region</b>	<b>Phone</b>	<b>Fax</b>
Asia-Pacific:	+886 2 25624117	+886 2 25624116
Europe:	+41 (0)41 768 5555	+41 (0)41 768 5510
Americas:	+1-951-781-5500	+1-951-781-5700

**[www.bourns.com](http://www.bourns.com)**

Bourns® products are available through an extensive network of manufacturer's representatives, agents and distributors. To obtain technical applications assistance, a quotation, or to place an order, contact a Bourns representative in your area.

Specifications subject to change without notice. Actual performance in specific customer applications may differ due to the influence of other variables. Customers should verify actual device performance in their specific applications.



*Reliable Electronic Solutions*

"Bourns" is a registered trademark of Bourns, Inc. in the U.S. and other countries.

COPYRIGHT© 2005, BOURNS, INC. • LITHO IN U.S.A. • XX 07/05 • XX/IC0505